

D-SUB protective cover - VS-15-SD - 1887099

Please be informed that the data shown in this PDF Document is generated from our Online Catalog. Please find the complete data in the user's documentation. Our General Terms of Use for Downloads are valid (<http://phoenixcontact.com/download>)

D-SUB protective cover, shell size 2, IP54 degree of protection, for panel mounting frame and sleeve housing VS-15-...



Key Commercial Data

Packing unit	5 pc
GTIN	
GTIN	4017918817473

Technical data

Mechanical characteristics

Locking type	without
Insertion/withdrawal cycles	≥ 1000
Color	gray
Degree of protection	IP54
Type	15
Size of housing	2

Ambient conditions

Ambient temperature (operation)	-40 °C ... 80 °C
---------------------------------	------------------

Material data

Flammability rating according to UL 94	V0
Housing material	PA
Material	Plastic

Standards and Regulations

Flammability rating according to UL 94	V0
--	----

Environmental Product Compliance

China RoHS	Environmentally friendly use period: unlimited = EFUP-e
------------	---

D-SUB protective cover - VS-15-SD - 1887099

Technical data

Environmental Product Compliance

	No hazardous substances above threshold values
--	--

Drawings

Dimensional drawing

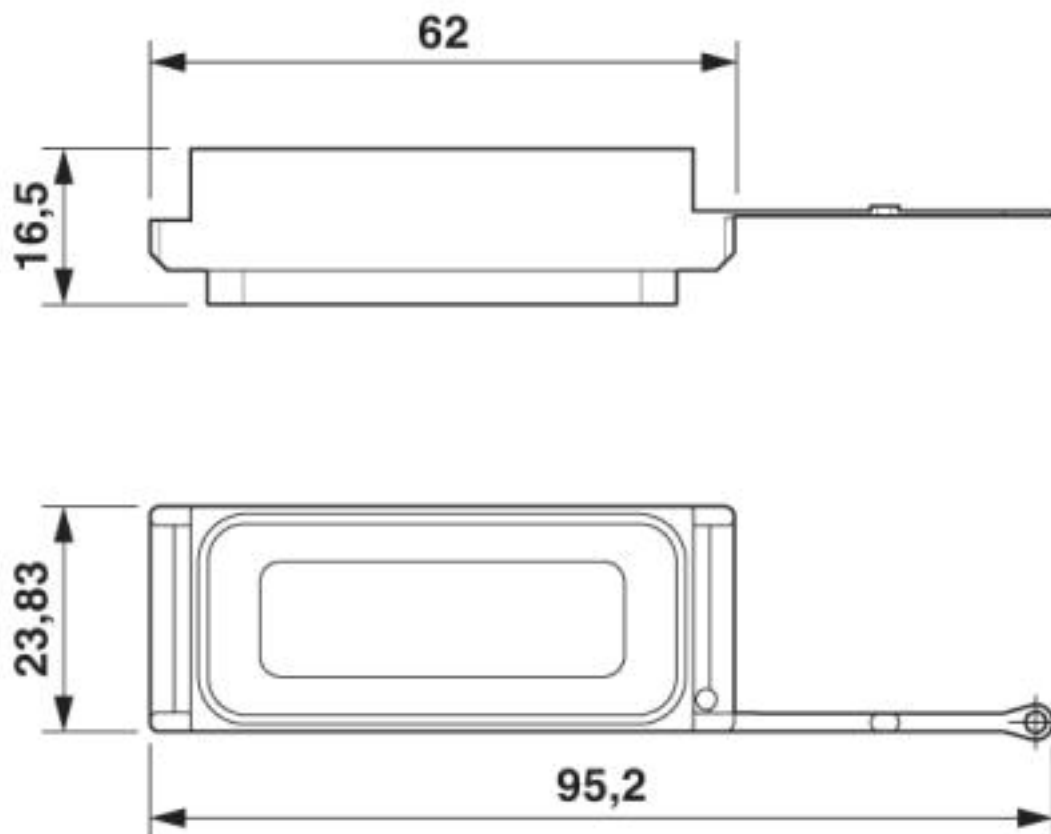

Protective cover for D-SUB

Phoenix Contact 2019 © - all rights reserved
<http://www.phoenixcontact.com>

PHOENIX CONTACT GmbH & Co. KG
Flachsmarktstr. 8
32825 Blomberg
Germany
Tel. +49 5235 300
Fax +49 5235 3 41200
<http://www.phoenixcontact.com>