

## SCSF0805SF Series Current Sensor Resistor (Lead / Halogen Free)

### Features / Applications :

- Power rating is up to 1/3W
- Low TCR current sensor
- Resistors are ideal for all types of current sensing
- Metal foil construction; Excellent long-term stability
- Moisture sensitivity level: MSL 1
- RoHS compliant

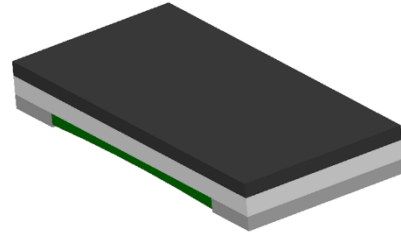

### Electrical Specifications :

| Characteristics <sup>1</sup>                  | Feature             |         |
|---|---------------------|---------|
| Power Rating <sup>2</sup>                     | 1/3 W               |         |
| Resistance Value(mΩ)                          | 1.5 to 4            | 5 to 20 |
| Temperature Coefficient of Resistance(ppm/°C) | ± 150               | ± 100   |
| Operation Temperature Range                   | -55°C to +170°C     |         |
| Maximum Working Voltage (V)                   | $(P \cdot R)^{1/2}$ |         |

Note :

1. For detailed information see table on page 3
2. For sensors operated at ambient temperature in excess of 70°C, the maximum load shall be derated in accordance with the following curve.

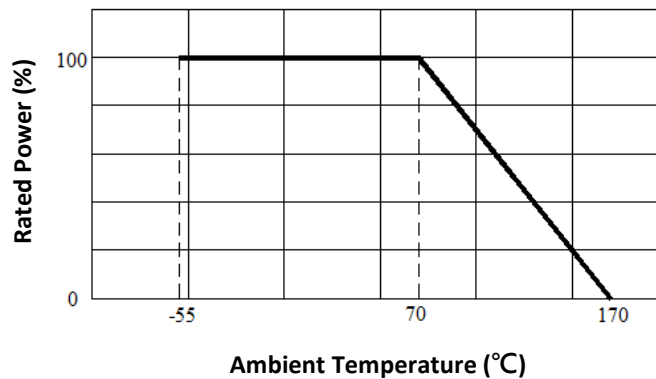
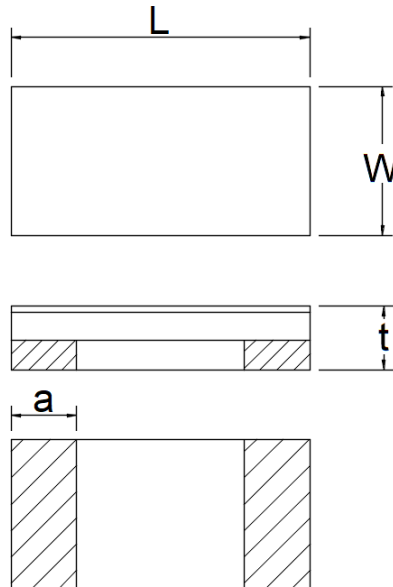

Figure 1. : Power Temperature Derating Curve

## Outline Drawing :

### Dimensions and schematic :



| Resistance Range(mΩ) | L         | W           | a         | t                             |
|----------------------|-----------|-------------|-----------|-------------------------------|
| 1.5 to 20            | 2.00±0.30 | 1.20 ± 0.30 | 0.40±0.20 | 0.6 <sup>+0.20</sup><br>-0.30 |

(Unit : mm)

## Type Designation :

SCSF 0805 S F- □□□□ □

(1) (2) (3) (4) (5) (6)

### Note :

- (1) Series No.
- (2) Size
- (3) Terminal : S = short terminal
- (4) Power Rating : F = 1/3W
- (5) Resistance value : 1R5m = 1.5mΩ ; R002 = 2mΩ ; R010 = 10mΩ
- (6) Tolerance : ±1%(F), ±2%(G), ±5%(J)

Available standard resistance values :

| Resistance Values | Tolerance |       |       |
|-------------------|-----------|-------|-------|
|                   | ±1.0%     | ±2.0% | ±5.0% |
| 1R5m              | ✓         | ✓     | ✓     |
| R002              | ✓         | ✓     | ✓     |
| R003              | ✓         | ✓     | ✓     |
| R004              | ✓         | ✓     | ✓     |
| R005              | ✓         | ✓     | ✓     |
| R006              | ✓         | ✓     | ✓     |
| R007              | ✓         | ✓     | ✓     |
| R008              | ✓         | ✓     | ✓     |
| R009              | ✓         | ✓     | ✓     |
| R010              | ✓         | ✓     | ✓     |
| R015              | ✓         | ✓     | ✓     |
| R020              | ✓         | ✓     | ✓     |

✓ = available

Further values and tolerances on request.

## Reliability Performance :

| Test Item                    | Condition of Test   | Requirements  |
|------------------------------|---|---|
| Short Time Overload          | 2.5 x Rated power for 5 seconds<br>Refer to JIS C 5201-1 4.13   | $\Delta R : \pm 0.5\%$  |
| Thermal Cycling              | -55 to 125°C 100 cycles, 15 min at each extreme condition<br>Refer to JIS C 5201-1 4.19   | $\Delta R : \pm 0.5\%$  |
| Low Temperature Storage      | Kept at -55°C, 1000 hours<br>Refer to JIS C 5201-1 4.23.4   | $\Delta R : \pm 1.0\%$  |
| Resistance to Soldering Heat | Dipped into solder at 260 ± 5°C for 10 ± 1 seconds<br>Refer to JIS C 5201-1 4.18  | $\Delta R : \pm 1.0\%$  |
| Load Life                    | Rated voltage for 1.5hours followed by a pause 0.5hour at 70 ± 3°C<br>Cycle repeated 1000 hours<br>Refer to JIS C 5201-1 4.25                                   | $\Delta R : \pm 1.0\%$  |
| Damp Heat with Load          | 40 ± 2°C with relative humidity 90% to 95%.<br>D.C. rated voltage for 1.5 hours ON and 30 minutes OFF. Cycle repeated 1,000 hours<br>Refer to JIS C 5201-1 4.24 | $\Delta R : \pm 1.0\%$  |
| High Temperature Exposure    | Kept at 170°C for 1000 hours<br>Refer to JIS C 5201-1 4.23.2  | $\Delta R : \pm 1.0\%$  |
| Solderability                | Temperature of Solder : 245 ± 5°C<br>Immersion Duration : 3 ± 0.5 second<br>Refer to JIS C 5201-1 4.17  | Uniform coating of solder cover minimum of 95% surface being immersed |
| Mechanical Shock             | 100 G's for 6milliseconds. 5 pulses<br>Refer to JIS C 5201-1 4.21   | $\Delta R : \pm 1.0\%$  |
| Substrate Bending            | Glass-Epoxy board thickness : 1.6mm<br>Bending width : 2mm<br>Between the fulcrums : 90mm<br>Refer to JIS C 5201-1 4.33   | $\Delta R : \pm 1.0\%$  |

Note : Measurement at 24±4 hours after test conclusion for all reliability tests-parts.

## Recommend Solder Pad Dimensions :

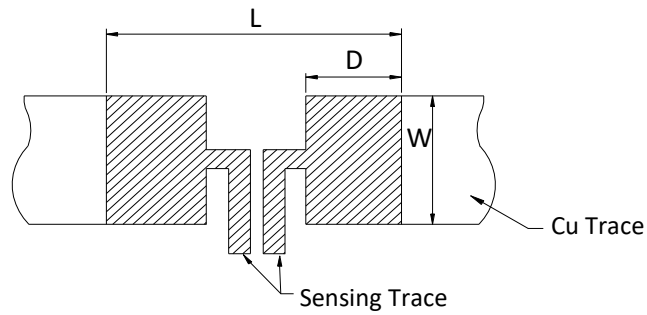

| Dimensions (mm) | W    | L    | D    |
|-----------------|------|------|------|
| 1.5 to 20 (mΩ)  | 1.98 | 3.60 | 1.40 |

## Packaging :

### Tape packaging dimensions :

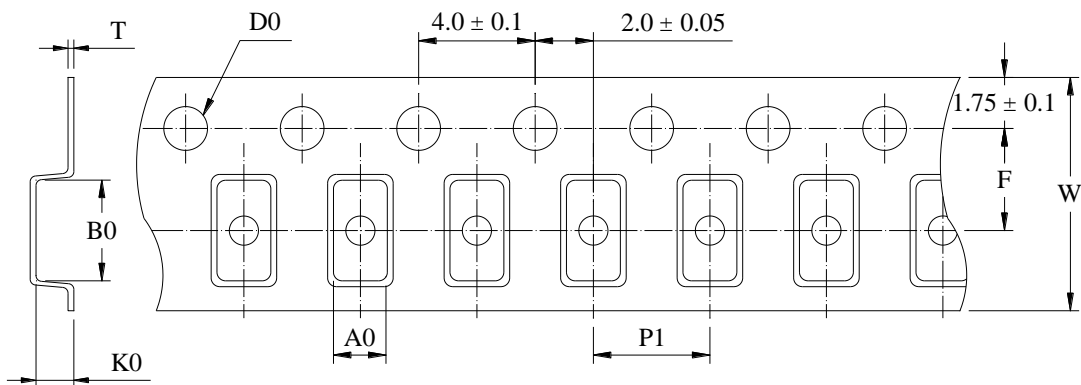

|    |             |    |              |
|----|-------------|----|--------------|
| A0 | 1.65 ± 0.10 | F  | 3.50 ± 0.05  |
| B0 | 2.35 ± 0.10 | P1 | 4.00 ± 0.10  |
| T  | 0.20 ± 0.10 | W  | 8.00 ± 0.30  |
| K0 | 1.05 ± 0.10 | D0 | φ1.55 ± 0.05 |

Reel dimensions :

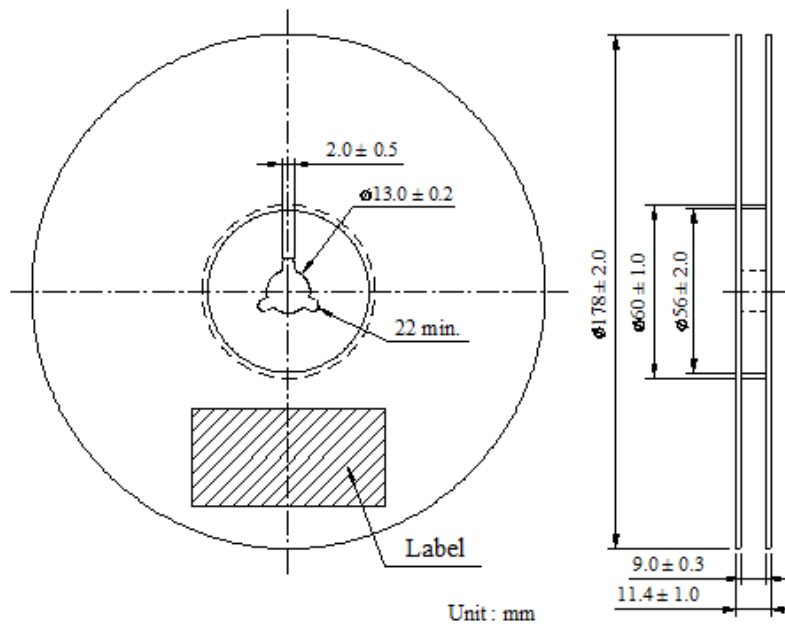

Peel Strength of Top Cover Tape :

The peel speed shall be about 300mm/min.

The peel force of top cover tape shall between 0.1 to 0.7N

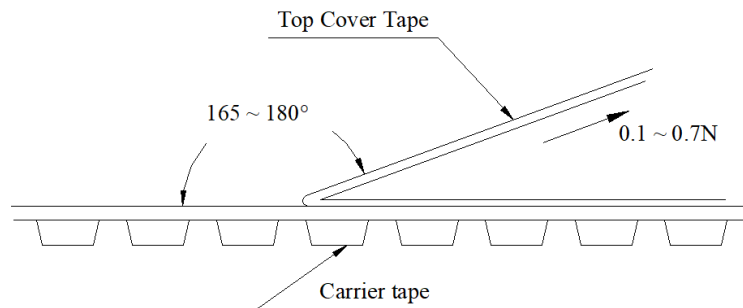

Number of Taping :

4,000 pieces / reel

Label Marking :

The following items shall be marked on the reel.

- (1) Type designation
- (2) Quantity
- (3) Manufacturing date code
- (4) Manufacturer's name
- (5) The country of origin

## Recommend Soldering Conditions:

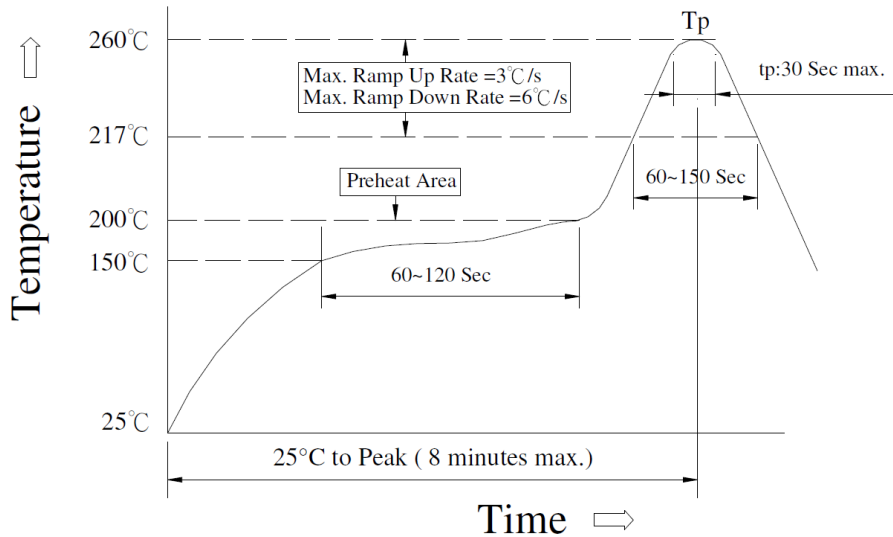

### Meet JEDEC-020D

#### (1) Reflow Soldering Method :

|                               |                                       |
|-------------------------------|---------------------------------------|
| Reflow Soldering              | Tp:255 to 260°C Max.30 seconds ( Tp ) |
|                               | 217°C 60 to 150 seconds               |
| Pre-Heat                      | 150 to 200°C 60 to 120 seconds        |
| Time 25°C to peak temperature | 8 minutes max                         |

#### (2) Soldering Iron Method : 350± 5°C max.3 seconds

## Care Note :

### Care note for storage

- (1) Current sensor shall be stored in a environment where temperature and humidity must be controlled (temperature 5 to 40°C, humidity 30 to 80% RH) . However, the humidity should be maintained as low as possible.
- (2) Current sensor shall not be stored under direct sunlight.
- (3) Current sensor shall be stored in condition without moisture, dust, any material defect solderability, or hazardous gas (i.e. Chlorination hydrogen, sulfurous acid gas, and sulfuration hydrogen)
- (4) The sensor can be stored for at least one year under the condition mentioned above.

### Care note for operating and handling

- (1) It is necessary to protect the edge and protection coat of resistors from mechanical stress.
- (2) Handle with care when printing circuit board (PCB) is divided or fixed on support body, because bending of printing circuit board (PCB) mounting will make mechanical stress for resistors.
- (3) Resistors shall be used with in rated range shown in specification. Especially, if voltage more than specified value will be loaded to resistor, there is a case it will make damage for machine because of temperature rise depending on generating of heat, and increase resistance value or breaks.
- (4) In case that resistor is loaded a rated voltage, it is necessary to confirms temperature of a resistor and to reduce a load power according to load reduction curve, because a temperature rise of a resistor depends on influence of heat from mounting density and neighboring element.
- (5) Observe Limiting element voltage and maximum overload voltage specified in each specification
- (6) If there is possibility that a large voltage (pulse voltage, shock voltage) charge to resistor, it is necessary that operating condition shall be set up before use.