

SW

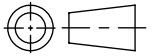

Revision level			Revision Record	Changed	Date	Approved	Date
Drawing	State	Part					
06.1	Design Release	-	SEE ECN# 014550	CTF	07/31/2018	GAL	07/31/2018

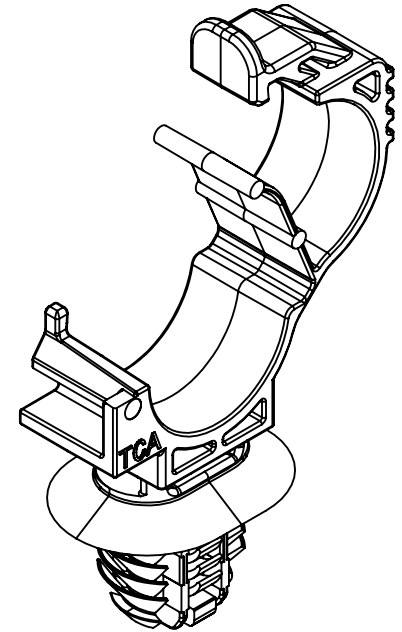
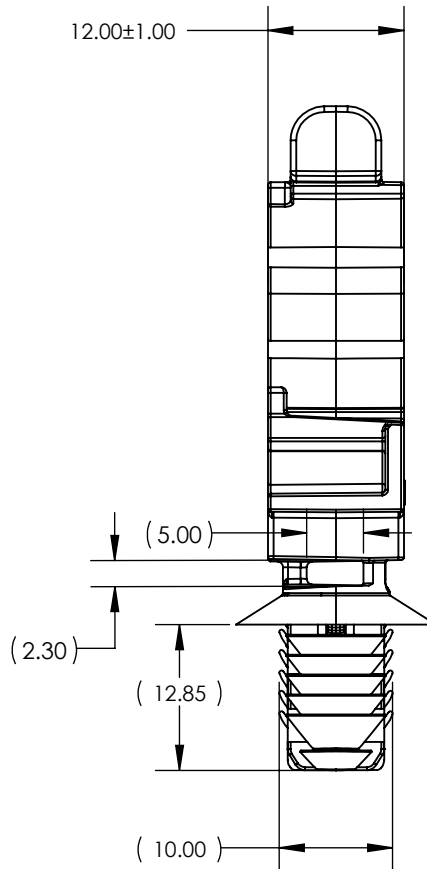
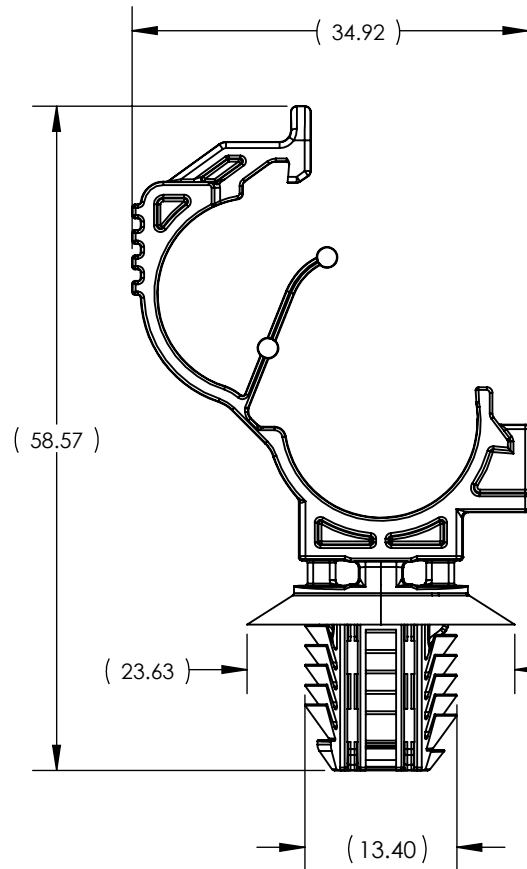
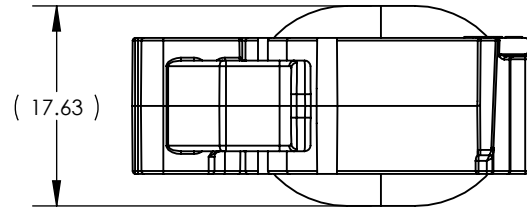

PERFORMANCE REQUIREMENTS:

1. FIR TREE PUSH IN FORCE: 45 NEWTONS (10LBS) MAX IN THE APPLICABLE NOMINAL HOLE SIZE AND A PLATE THICKNESS OF 1.5mm.
2. FIR TREE PULL OUT FORCE: 156 NEWTONS (35LBS) MIN IN THE APPLICABLE NOMINAL HOLE SIZE AND A PLATE THICKNESS OF 1.5mm.
3. SHEET METAL THICKNESS RANGE: 0.60mm - 6.75mm
4. APPLICABLE OVAL HOLE SIZE:
  - A. 9.0 X 12.0mm +/-0.2mm
5. MECHANICAL STRENGTH: 156 NEWTONS (35LBS) MIN IN THE APPLICABLE NOMINAL HOLE SIZE AND A PLATE THICKNESS OF 1.5mm WITH A 12.5mm MANDREL.

GLOBAL PART DESCRIPTION	MATERIAL	COLOR
LOC1014FT9x12-PA66HIRHSUV-BK	PA66HIRHSUV	BLACK

Material  
SEE CHART

Units: **millimeters**  
  
Tolerance defined on each dimension

The copyright of this drawing is reserved by HellermannTyton. It is issued on condition that it is not reproduced, copied, or disclosed to a third party, either wholly or in part, without the consent of HellermannTyton.

Drawn	GAL	7/18/2017
Approved	KAC	7/18/2017

**HellermannTyton**  
North America  
Email: corp@htamericas.com  
Web: www.hellermann.tyton.com

Article/Type-No LOC10-14FT9X12  
Title LOCKING CLAMP (10 TO 14mm BUNDLE) WITH 9X12 OVAL FIR TREE  
Drawing-No 17-1047-001-CSU  
Production : Phase

Scale 3:2  
Project Number PRP 17-1047  
Format AH  
Sheet 1/1