

LOC	DIST	REVISIONS			
P	LTR	DESCRIPTION	DATE	DWN	APVD
C		0-2141264-3 Durchmesser 9.4 war 10.0	27MAY2015	RSC	FWI
C1		Revisionspunkte in Tabelle hinzu	24NOV2016	RSC	KKI
C2		0-2141264-2 has been reactivated	31MAR2021	SK	TS

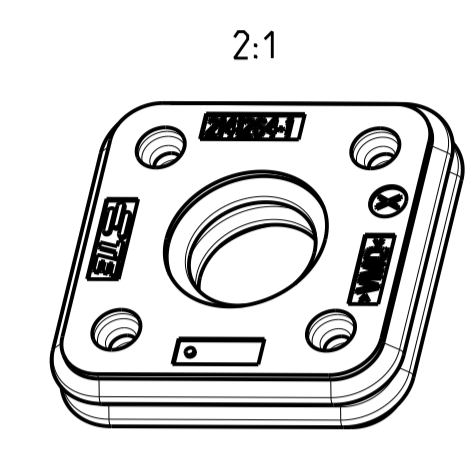
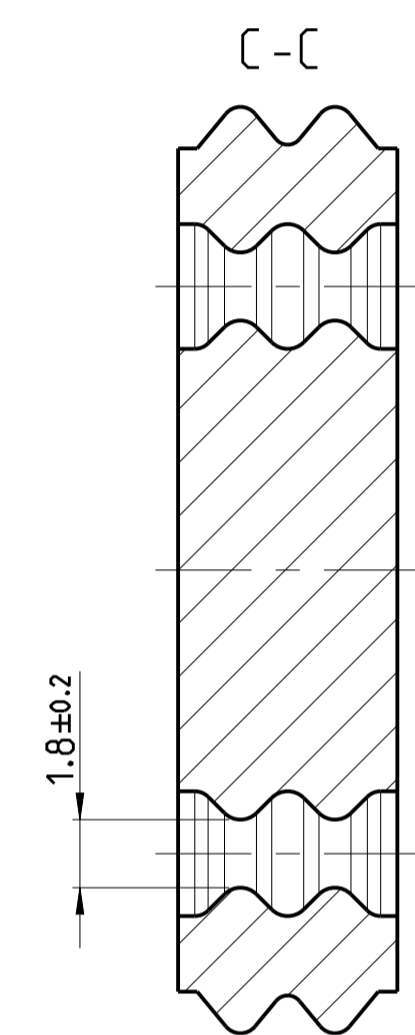
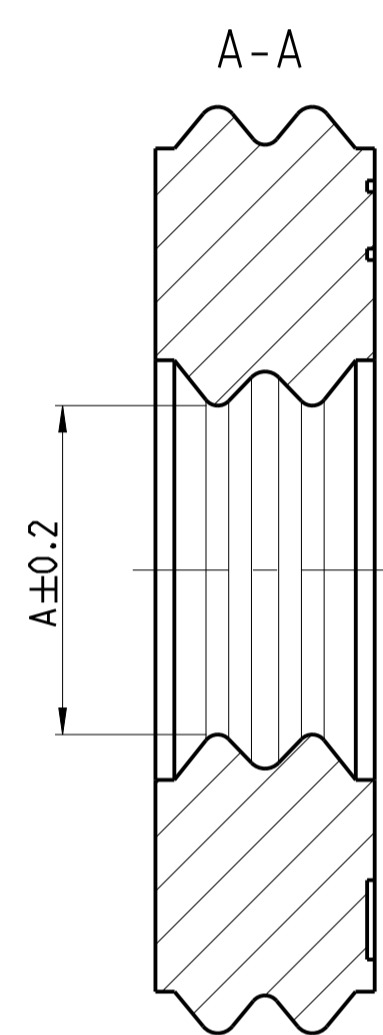
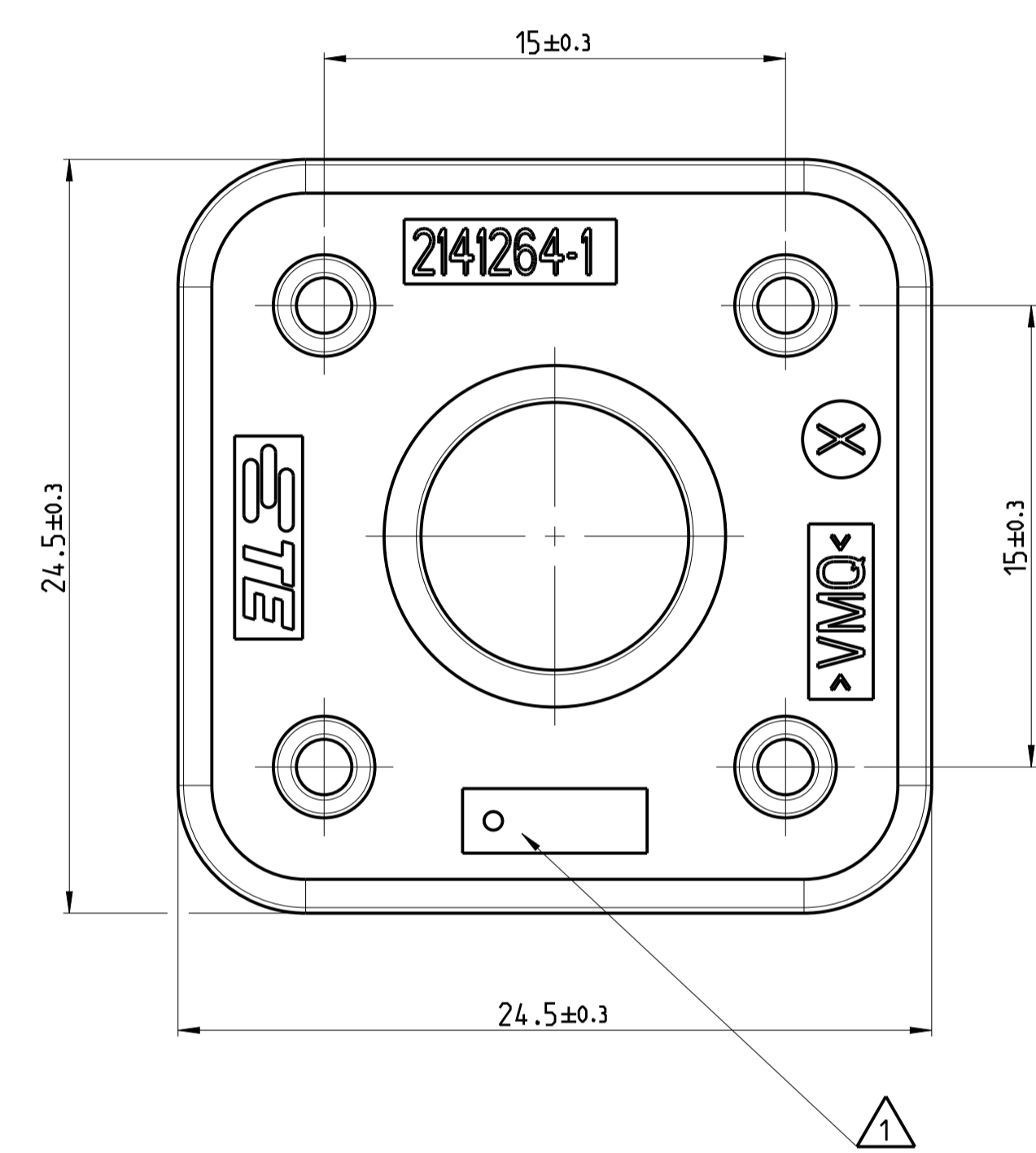

TE ORDER NO.	REV	DESCRIPTION	DIMENSION A	FOR WIRE ISOLATION DIAMETER [mm]	MATERIAL	WEIGHT [g]	COLOUR
2141264-4	A (1 DOT)	SINGLE WIRE SEAL, AMP MCP6.3/4.8K Kabeldichtung einzeln, AMP MCP6.3/4.8K	11.5	12.2 - 12.8	SILICON	3	YELLOW
2141264-3	B (3 DOTS)		9.4	10.7 - 11.3			BLUE
2141264-2	A (1 DOT)		8.2	9.3 - 9.9			GREEN
2141264-1	-		8.7	9.9 - 10.5			WHITE

NOTE Bem.	FEATURE Merkmal	TE-PART-NO. Teil-Nr.
1	ENTIRE ASSEMBLY SEE Gesamtzusammenbau siehe	114-94100-1
2	PRODUCT-SPEC. Produkt-Spez.	108-94264
3	APPLICATION SPEC. Verarbeitungsspez.	114-94100

THIS DRAWING IS A CONTROLLED DOCUMENT. DIMENSIONING AND TOLERANCING PER GPS (ISO STANDARDS)

DW: Vishwa A 08FEB2011
 CHK: U. Hoedchner 28APR2011
 APVD: T. Reissenrodt 04MAY2011

NAME: SINGLE WIRE SEAL, AMP MCP6.3/4.8K
 Kabeldichtung einzeln, AMP MCP6.3/4.8K

SIZE: CAGE CODE DRAWING NO. RESTRICTED TO
 A1 00779 C=2141264

SCALE: 5:1 SHEET 1 OF 2 REV: 2

LOC	DIST	REV	DATE	DWN	APVD
A1	-	-	-	-	-
PRODUCT NO.:		SEE SHEET 1			

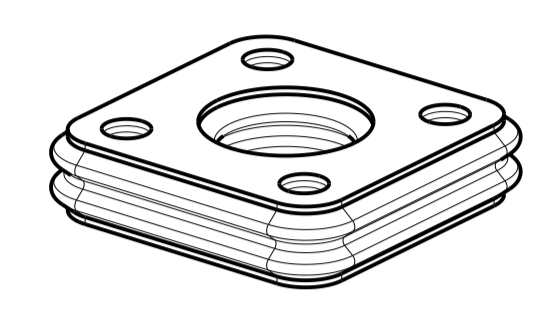
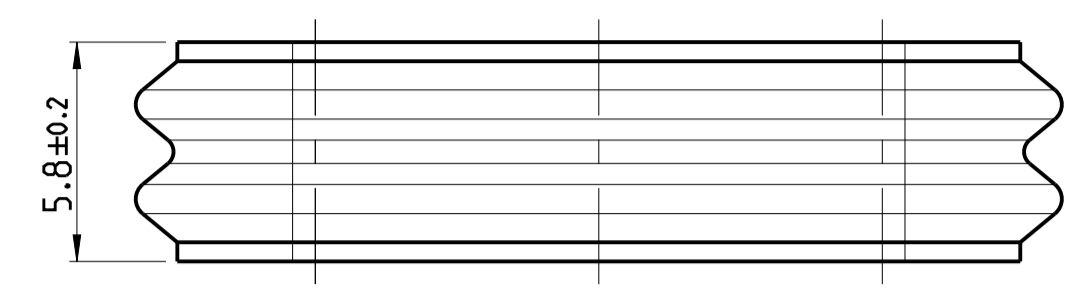

2:1

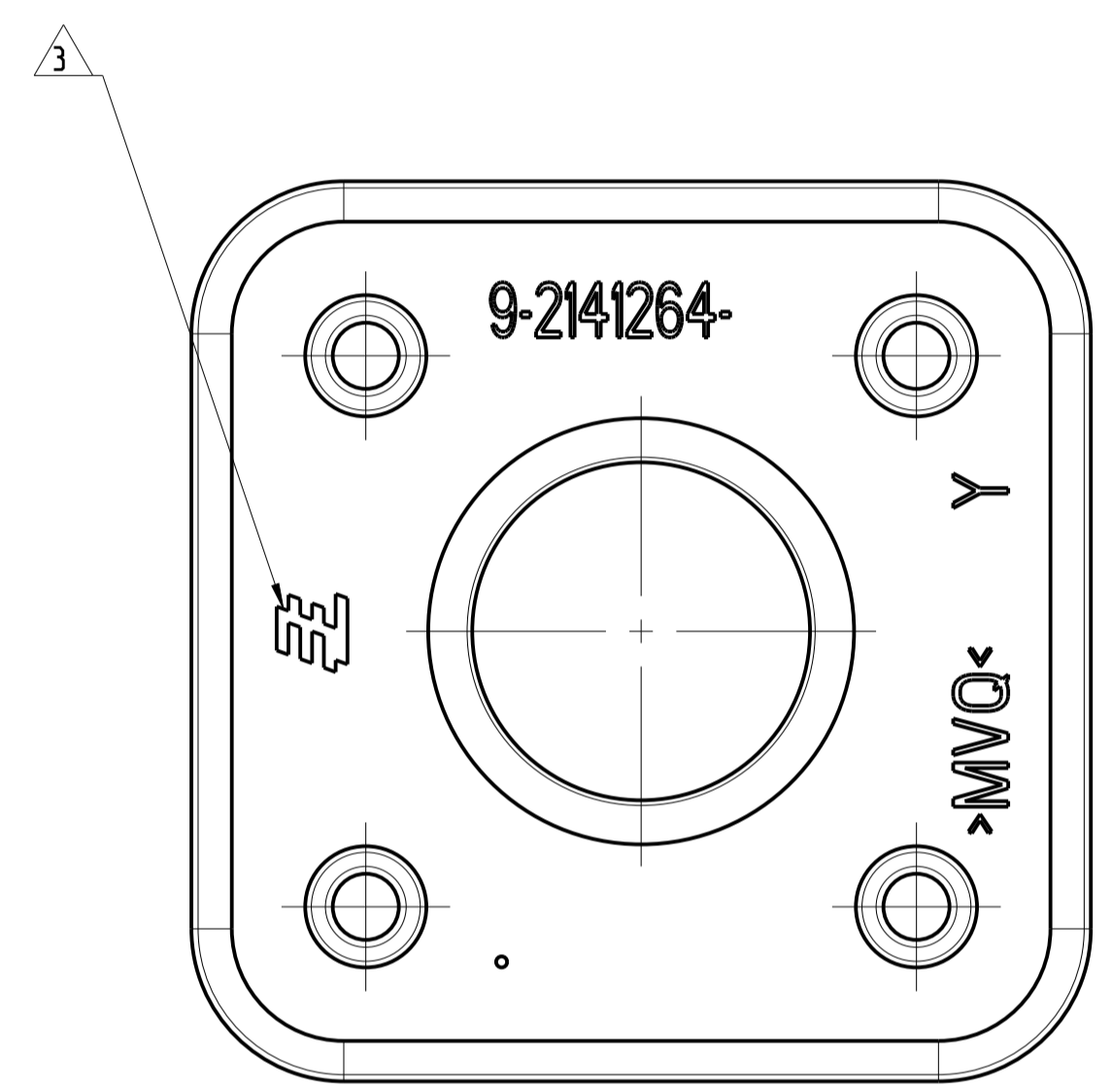
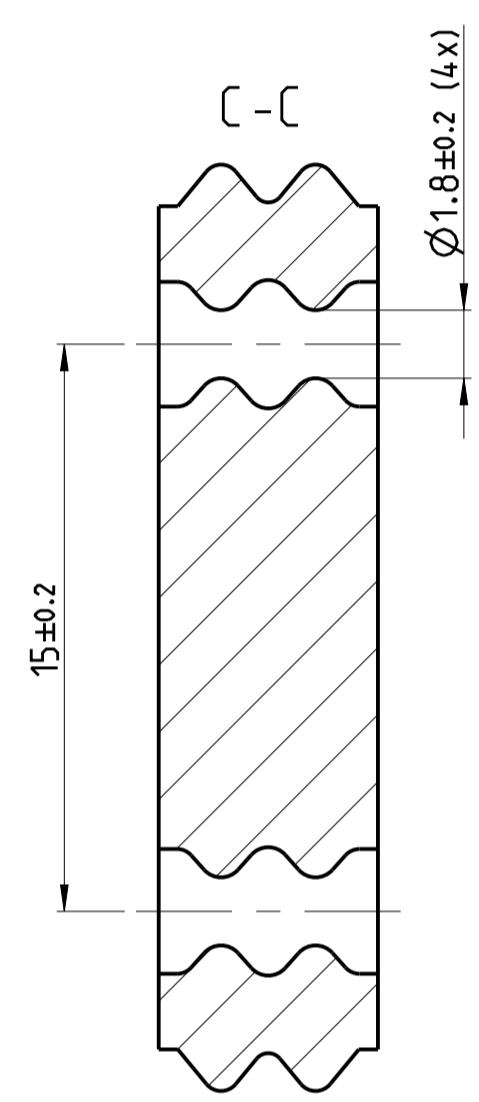
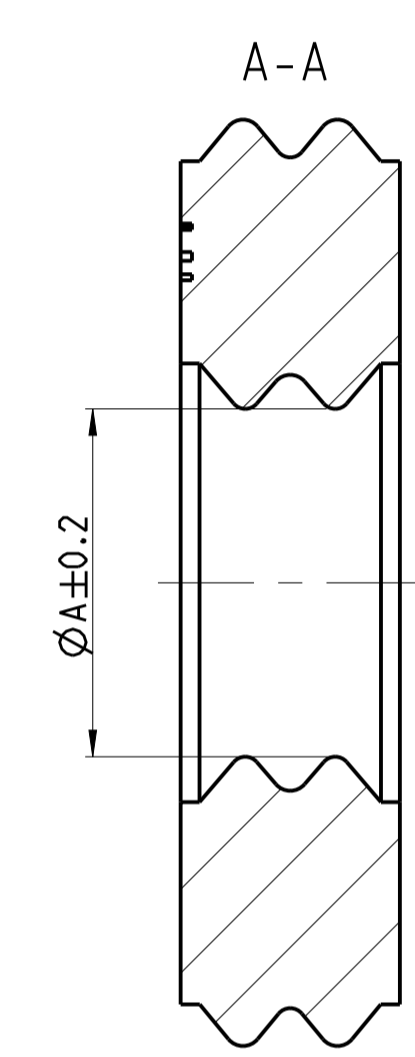
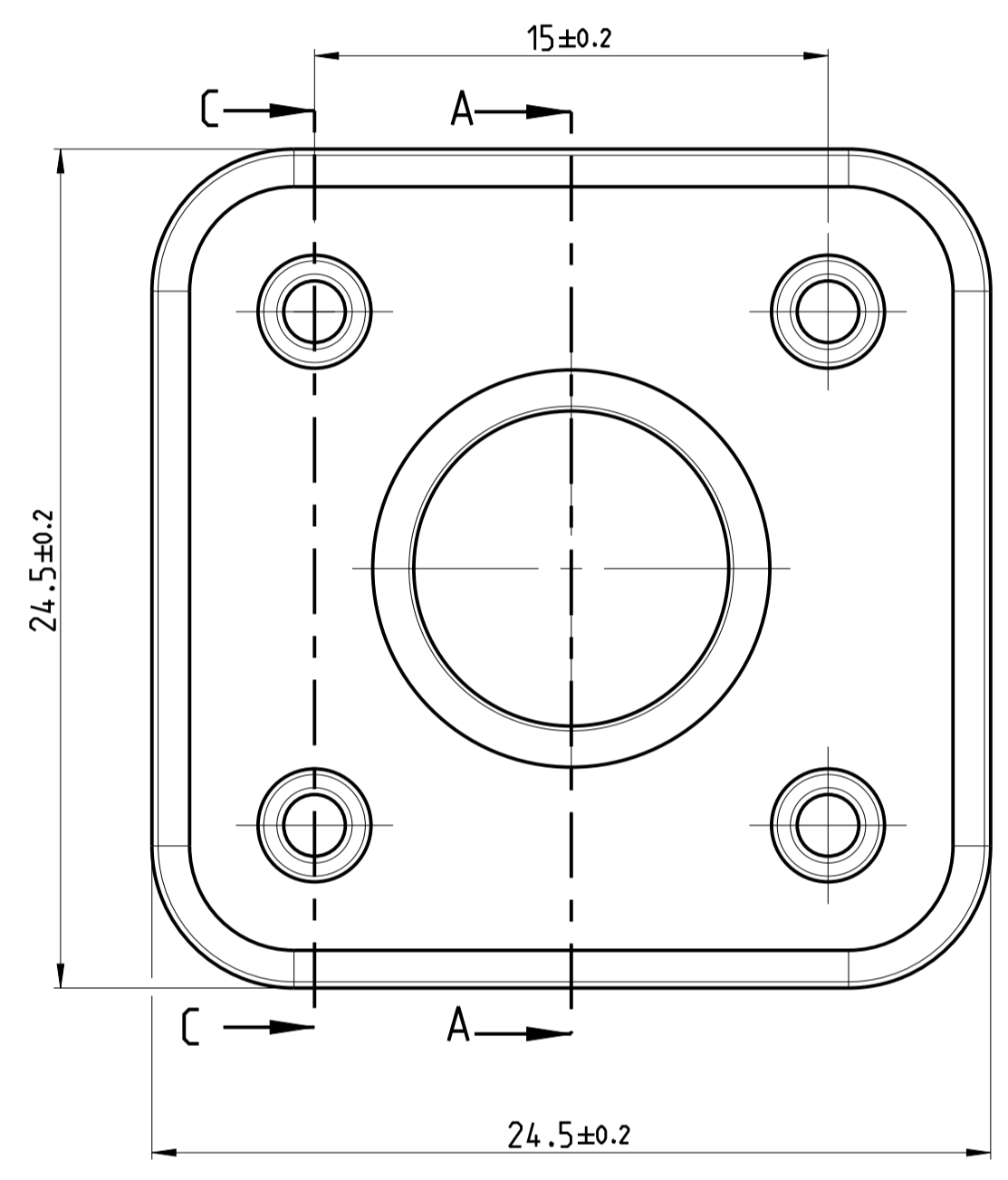

NOTES:

Bemerkungen:

- ONLY THE GERMAN LANGUAGE IS AUTHORITATIVE
Maßgebend ist der deutsche Text
- PACKAGING: BULK PACKAGING IN AIRTIGHT PE-PACKET
Verpackung: Schüttgut in PE-Beutel luftdicht verpackt

3 SUPPLIER-MARK
Lieferanten Kennzeichnung

NOTE Bem.	FEATURE Merkmal	TE-PART-NO. Teil-Nr.
4	ENTIRE ASSEMBLY SEE Gesamtzusammenbau siehe	114-94100-1
5	PRODUCT-SPEC. Produkt-Spez.	108-94264
6	APPLICATION SPEC. Verarbeitungsspez.	114-94100

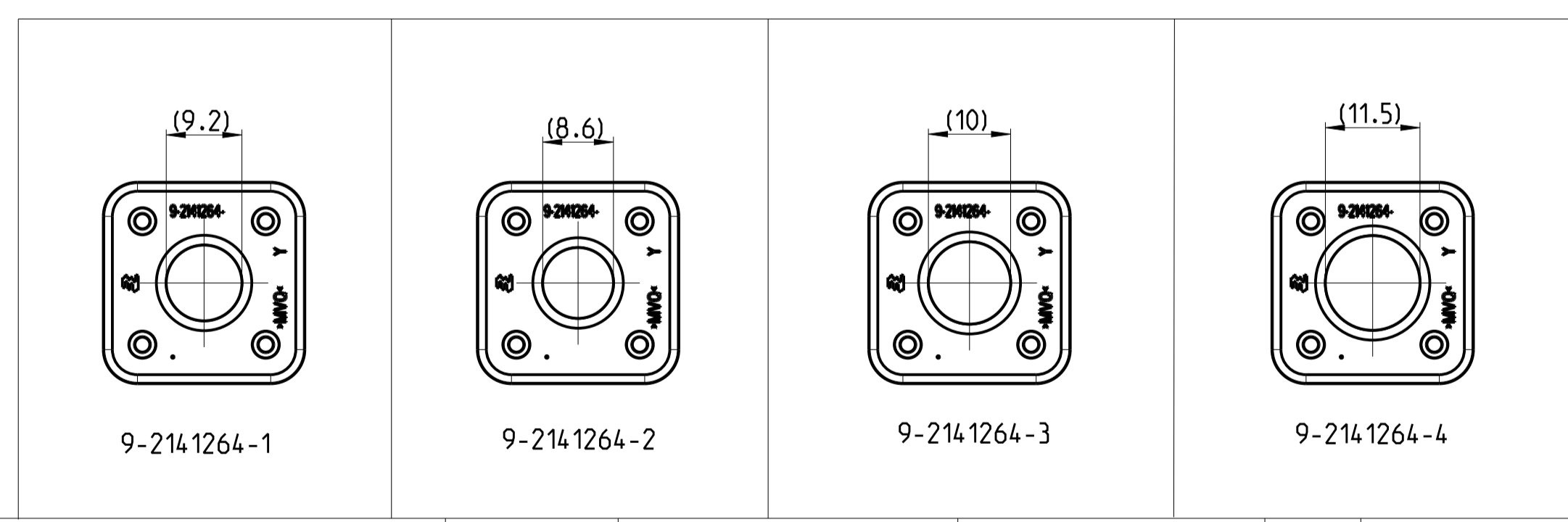

TE ORDER NO.	REV	DESCRIPTION	DIMENSION A	FOR WIRE ISOLATION DIAMETER [mm]	MATERIAL	WEIGHT [g]	COLOUR
9-2141264-4	A	SINGLE WIRE SEAL, AMP MCP6.3/4.8K Kabeldichtung einzeln, AMP MCP6.3/4.8K	11.5	12.2 - 12.8	SILICON	3	YELLOW
9-2141264-3	A		10	10.7 - 11.3			NATURAL
9-2141264-2	A		8.6	9.3 - 9.9			GREEN
9-2141264-1	A		9.2	9.9 - 10.5			WHITE

TE TE Connectivity
 SINGLE WIRE SEAL, AMP MCP6.3/4.8K
 Kabeldichtung einzeln, AMP MCP6.3/4.8K
 DRAWING NO. 00779 / KUNDENZICHNUNG
 SCALE 5:1 / MASSSTAB
 SHEET 2 OF 2 / BLATT 2 VON 2
 DATE 28APR2011 / DATED
 DWG U.Hoedinger / DRAWN
 APVD I.Reisenberger / APPROVED
 04MAY2011 / DATE
 THIS DRAWING IS A CONTROLLED DOCUMENT.
 TOLERANCES UNLESS OTHERWISE SPECIFIED ACC. TO DIN 16001-140 CENTRIC TO NOMINAL DIMENSION, EDITION 1982-11.
 TOLERANZUNGEN UNLESS OTHERWISE SPECIFIED ACC. TO DIN 16001-140, ES GILT DIE AUSGABE 1982-11.
 PRODUCT CHARACTERISTICS ACC. QMP EMEA_12
 BESONDERE MERKMALE NACH QMP EMEA_12
 TOLERANCING ISO 8015
 TOLERIERUNG ISO 8015
 THIS DRAWING IS A CONTROLLED DOCUMENT.
 DWG Vishwa A 08FEB2011
 CHK U.Hoedinger 28APR2011
 APVD I.Reisenberger 04MAY2011
 PRODUCT SPEC. 5
 APPLICATION SPEC. 6
 MATERIAL -
 WEIGHT SEE TABLE
 CUSTOMER DRAWING
 RESTRICTED TO NEW PUR
 SCALE 5:1
 SHEET 2 OF 2
 REV C 2