

THIS DRAWING IS UNPUBLISHED. RELEASED FOR PUBLICATION
 © COPYRIGHT - By - ALL RIGHTS RESERVED.

REVISIONS					
P	LTR	DESCRIPTION	DATE	DWN	APVD
	G1	REVISED PER ECR-16-014800	24OCT2016	RS	DR
	G2	REVISED PER ECR-16-016653	02DEC2016	RS	DR

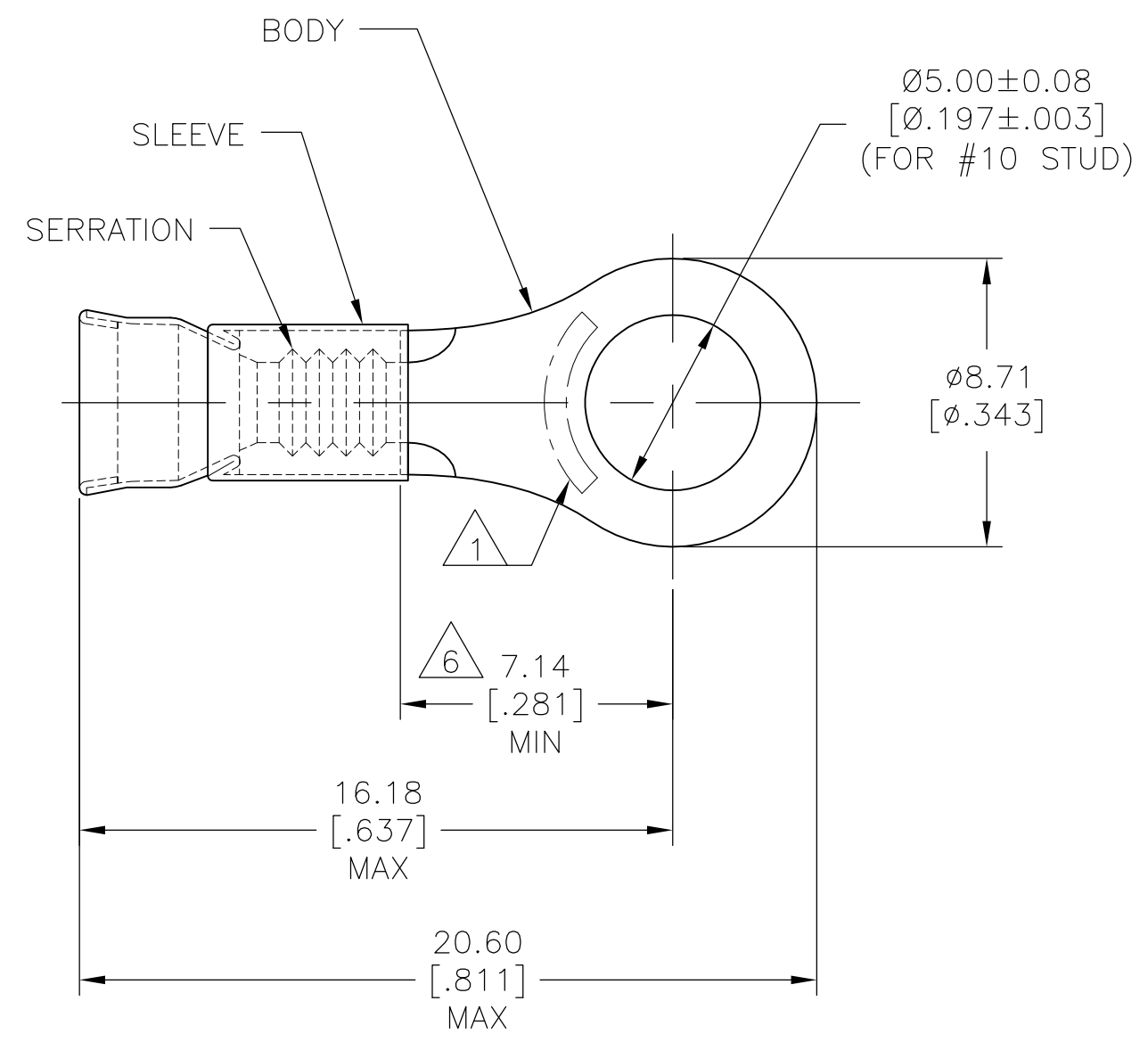

- 1 STAMP AMP 16-14* APPROX AS SHOWN.
- 2. WIRE INSUL DIA, 3.05-4.32[.120-.170]
- 3. TONGUE MATL THK, 0.79±0.05[.031±.002]
- 4. NOTE DELETED.
- 5 PARTS MOUNTED ON TAPE WIRE BARREL FACING DOWN.
- 6 APPLIES FROM EDGE OF METAL WIRE BARREL TO CENTER OF STUD HOLE.

5	5000	ON TAPE, REEL	2-322375-1
	1000	LOOSE PIECE	322375
	QTY	PACKAGE TYPE	PART NO

AMP INCORPORATED
 CUSTOMER SERVICE SYSTEMS

THIS DRAWING IS A CONTROLLED DOCUMENT.

DWN	L OLMEDA	10OCT94
CHK	M ELLIS	10OCT94
APVD	S BORTNER	10OCT94
PRODUCT SPEC	-	
APPLICATION SPEC	-	
WEIGHT	-	



NAME: TERMINAL, RING TONGUE, STRATOTHERM, DIAMOND GRIP, WIRE SIZE, 16-14 AWG

FOR ADDITIONAL PRODUCT INFORMATION OR COPIES OF DRAWINGS AND TECHNICAL DOCUMENTS	PRODUCT INFORMATION CENTER 1-800-522-6752	MAX RECOMMENDED OPERATING TEMPERATURE: 343°C [650°F]
FOR APPLICATION TOOLING INFORMATION	TOOLING ASSISTANCE CENTER 1-800-722-1111	VOLTAGE RATING: NOT APPLICABLE
FOR ORDER ENTRY	1-800-526-5142	CIRCULAR MILL AREA: 1.04mm²-2.62mm²[2050-5180] STRANDED WIRE

DIMENSIONS: mm [INCHES]	TOLERANCES UNLESS OTHERWISE SPECIFIED:
	0 PLC ± -
	1 PLC ± -
	2 PLC ± 0.20 [.008]
	3 PLC ± -
	4 PLC ± -
	ANGLES ± -
MATERIAL BODY, CU PER ASTM B152 SLEEVE, NI SIL PER ASTM B122	FINISH BODY, NP, SAE AMS QQ-N-290

SIZE	CAGE CODE	DRAWING NO	RESTRICTED TO
A3	00779	C-322375	-
CUSTOMER DRAWING		SCALE 6:1	SHEET 1 OF 1 REV G2