

PAGE 1/3	ISSUE 08-02-16B	SERIES BMA	PART NUMBER R128639020
----------	------------------------	-------------------	-------------------------------

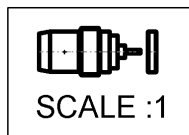

All dimensions are in mm.

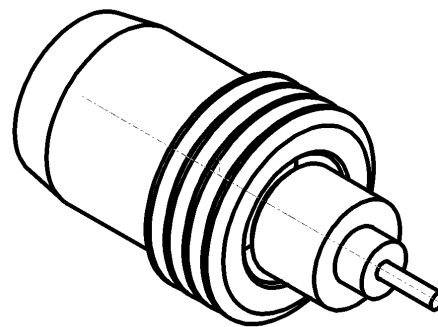
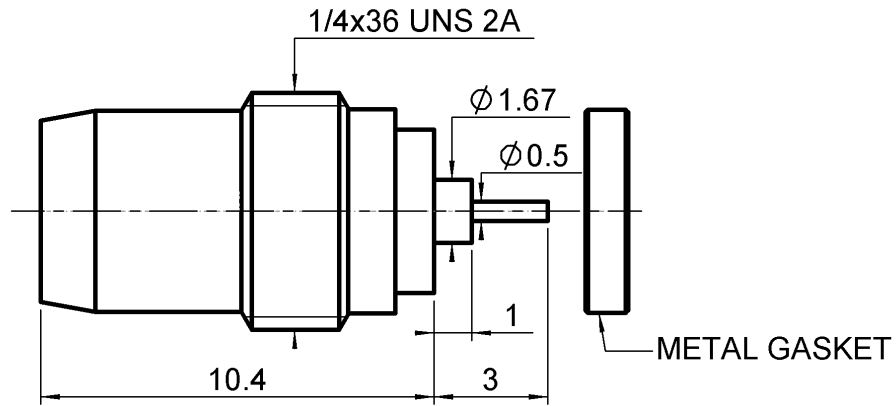
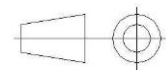

COMPONENTS	MATERIALS	PLATING (µm)
Body	STAINLESS STEEL	GOLD 0.5 OVER NICKEL 2
Center contact	BERYLLIUM COPPER	GOLD 1.3 OVER NICKEL2
Outer contact	-	-
Insulator	PTFE	-
Gasket	A-G4MC	-
Others parts	-	-
-	-	-
-	-	-

PAGE 2/3	ISSUE 08-02-16B	SERIES BMA	PART NUMBER R128639020
----------	------------------------	-------------------	-------------------------------

PACKAGING

Standard	Unit	Other
1	Contact us	Contact us

ELECTRICAL CHARACTERISTICS

Impedance		50	Ω
Frequency		0-22	GHz
VSWR	1.04	+	0,0090 x F(GHz) Maxi
Insertion loss		0.03	√F(GHz) dB Maxi
RF leakage	- (NA	- F(GHz)) dB Maxi
Voltage rating		500	Veff Maxi
Dielectric withstanding voltage		1500	Veff mini
Insulation resistance		5000	MΩ mini

ENVIRONMENTAL

Operating temperature	-65/+125	°C
Hermetic seal	10-8	Atm.cm3/s
Panel leakage	NA	

MECHANICAL CHARACTERISTICS

Center contact retention			
Axial force – Mating End		27	N mini
Axial force – Opposite end		27	N mini
Torque		NA	N.cm mini
Recommended torque			
Mating		NA	N.cm
Panel nut		280	N.cm
Mating life		1000	Cycles mini
Weight		1,2320	g

SPECIFICATION

OTHER CHARACTERISTICS

Assembly instruction:**NA**

Others:

-

PAGE 3/3	ISSUE 08-02-16B	SERIES BMA	PART NUMBER R128639020
----------	-----------------	------------	------------------------

PANEL DRILLING

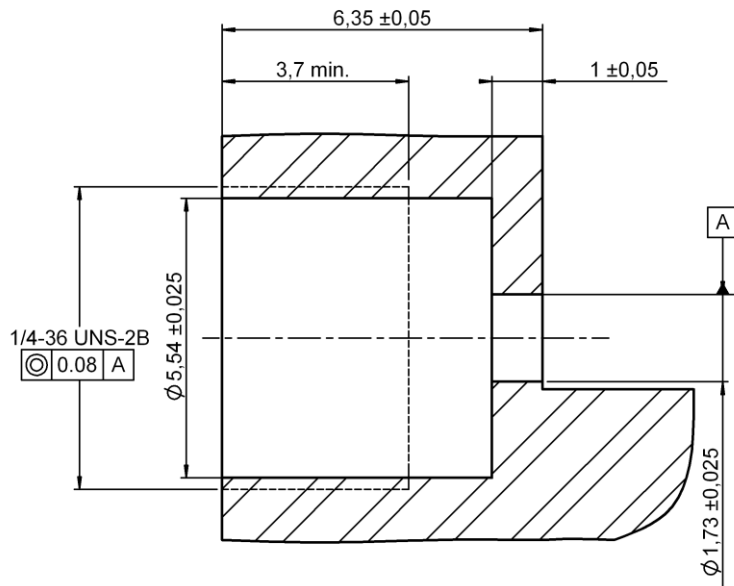

MOUNTING HOLE DETAIL

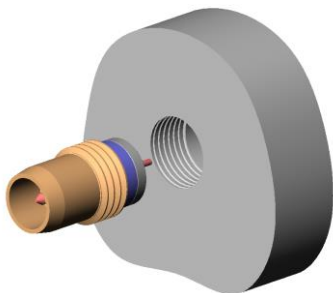
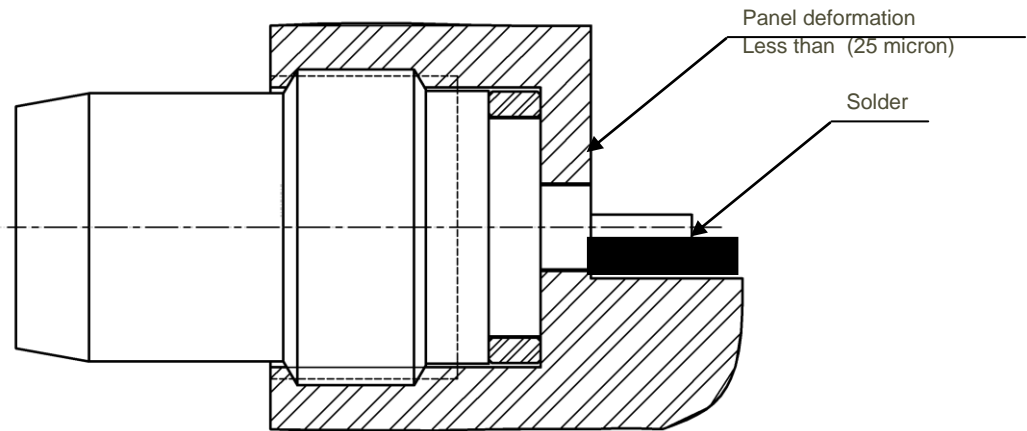

Assemble metal gasket onto connector. Screw both parts into the housing. Tighten the connector up to 280 Ncm torque (use special tooling set RADIALL R282 340). Thus the connection hermeticity is guaranteed at $1 \cdot 10^{-8}$ atm.cm³/sec. Then solder the pin.
Be careful not put too much solder.