

THIS DRAWING IS UNPUBLISHED. RELEASED FOR PUBLICATION, 19 .
 © COPYRIGHT 19 BY AMP INCORPORATED. ALL INTERNATIONAL RIGHTS RESERVED.

LOC	DIST	P	F	ZONE	LTR	DESCRIPTION	DATE	APPD
G	14				B	REVISED PER OL20-0141-97	30JUN97	OKS MJS

METRIC
 DIMENSIONS LISTED IN mm [INCHES]

AMP WIRE RANGE	UL E13288 Listed
12-10 AWG STRANDED	12-10 AWG STRANDED
SR LR7189 Certified	MILITARY P/N AND CLASS
NOT CERTIFIED	NOT APPLICABLE

△ STAMP AMP 12-10* APPROX AS SHOWN

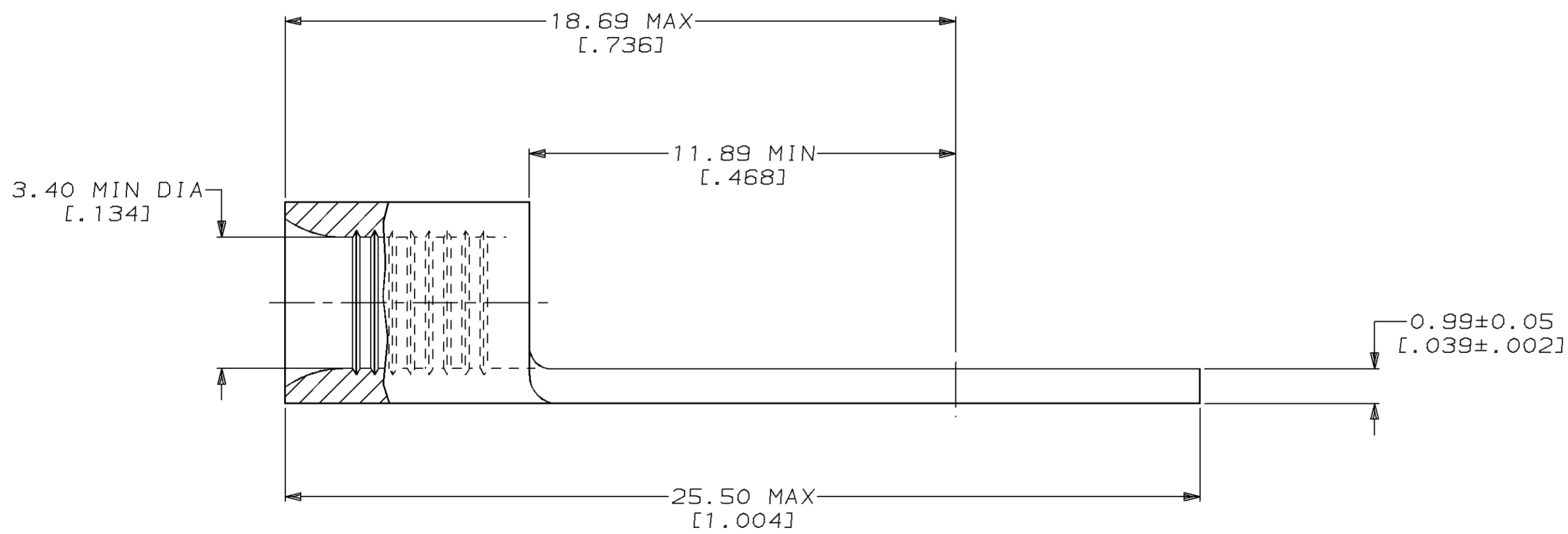
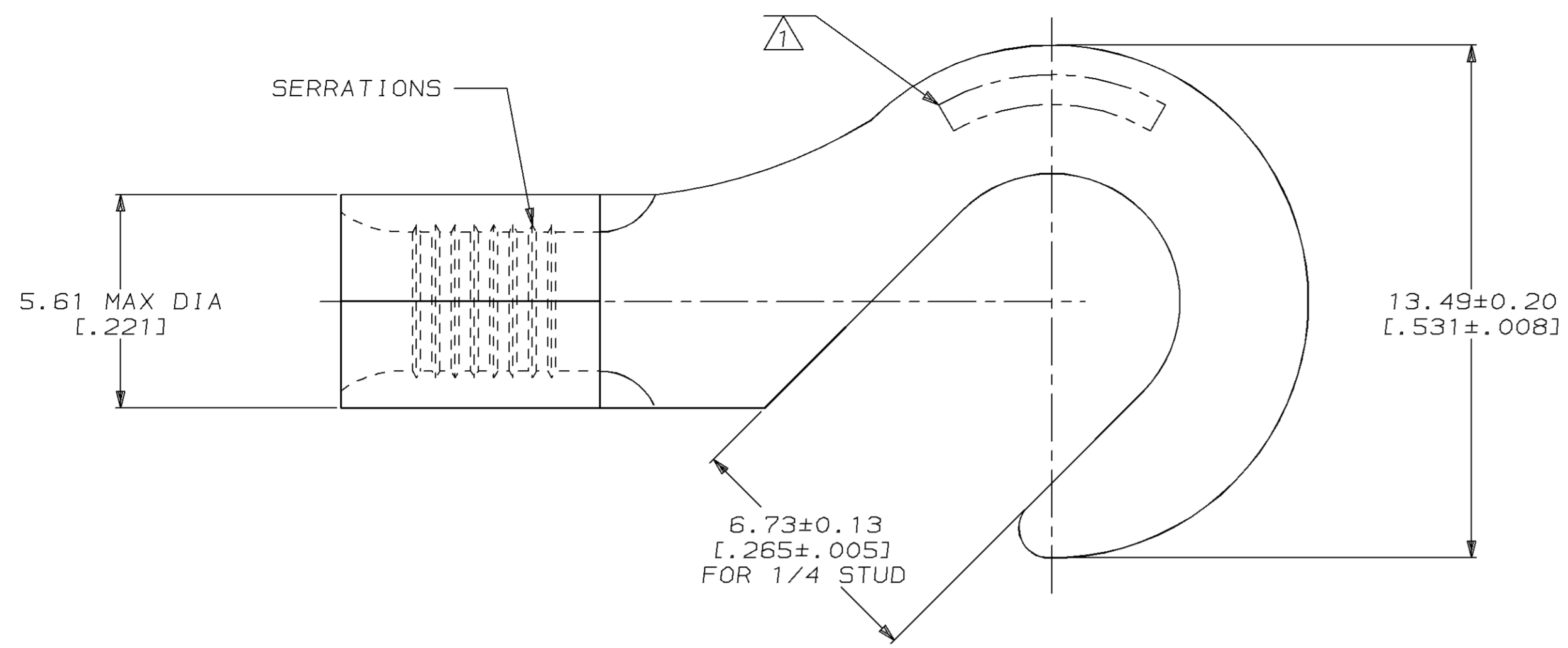

2500	ON TAPE, REEL	327905-1
-	LOOSE PIECE	327905
QUANTITY	PACKAGE TYPE	PART NO

AMP INCORPORATED
CUSTOMER SERVICE SYSTEMS

FOR ADDITIONAL PRODUCT INFORMATION OR COPIES OF DRAWINGS AND TECHNICAL DOCUMENTS	PRODUCT INFORMATION CENTER 1-800-522-6752
FOR APPLICATION TOOLING INFORMATION	TOOLING ASSISTANCE CENTER 1-800-722-1111
FOR ORDER ENTRY	1-800-526-5142

MAX RECOMMENDED OPERATING TEMPERATURE:
 170°C MAX

VOLTAGE RATING:
 NOT APPLICABLE

WIRE CROSS SECTIONAL AREA RANGE:
 2.62-6.64mm² [5, 180-13, 100] CIR MILS STRANDED

THIS DRAWING IS A CONTROLLED DOCUMENT FOR AMP INCORPORATED. IT IS SUBJECT TO CHANGE AND THE CONTROLLING ENGINEERING ORGANIZATION SHOULD BE CONTACTED FOR THE LATEST REVISION.

DO NOT SCALE PRINT. UNLESS SPECIFIED DIMENSIONS IN mm [INCHES]— TOLERANCES ON :
 2 PLC DEC ± -
 3 PLC DEC ± -
 ANGLES ± -

MATERIAL
 COPPER PER ASTM B-152 ANNEALED

FINISH
 TIN PLATE 0.00254 [0.000100] MIN THK PER MIL-T-10727

DR 2-27-93
 TA BRINKMAN

CHK 2-27-93
 DA PATTERSON

APPD 2-27-93
 DE MILLER

APPD 2-27-93
 JL MECKLEY

PRODUCT SPEC -

APPLICATION SPEC -

WEIGHT -

AMP AMP Incorporated
 Harrisburg, PA 17105-3608

NAME
TERMINAL, HOOK TONGUE, BUDGET

SIZE	CAGE CODE	DRAWING NO
③	00779	③-327905
SCALE	8:1	SHEET 1 OF 1