

- テール平坦度は、0.08以下
テール及び金具の平坦度は、0.1以下
TAIL COPLANARITY TO BE 0.08MAXIMUM
TAIL AND FITTING NAIL COPLANARITY TO BE 0.1MAXIMUM
- 同一回路以外のパターン書込み禁止範囲を示す。
NO PRINT CIRCUIT AREA OTHER THAN THE SAME CIRCUIT.
- ELV及びRoHS適合品。
ELV AND RoHS COMPLIANT.

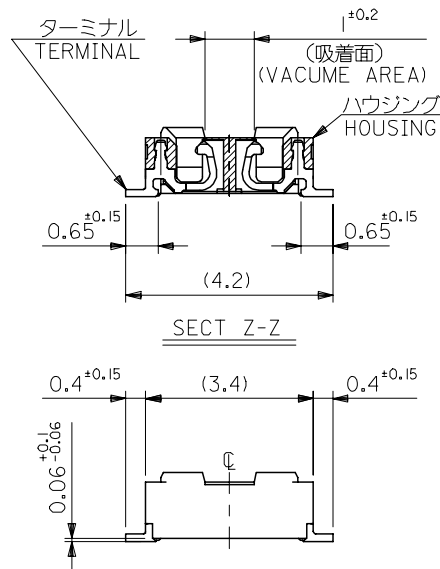

注記 NOTES:

- 使用材料 MATERIAL
ハウジング: 液晶ポリマー (LCP) ガラス充填
UL94V-0 (黒)
HOUSING: LIQUID CRYSTAL POLYMER (GLASS FILLED)
UL94V-0 (COLOR: BLACK)
ターミナル: リン青銅 (t=0.15)
TERMINAL: PHOSPHOR BRONZE (t=0.15)
金具: リン青銅 (t=0.15)
FITTING NAIL: PHOSPHOR BRONZE (t=0.15)
- メッキ仕様 PLATING
ターミナル TERMINAL
金メッキ 0.2マイクロメートル以上 (コンタクト部)
GOLD 0.2MICROMETER MINIMUM (CONTACT AREA)
金メッキ 0.4マイクロメートル以下 (テール部)
GOLD 0.4MICROMETER MAXIMUM (TAIL AREA)
下地メッキ: ニッケルメッキ 1.5マイクロメートル以上
*コンタクト部とテール部はニッケルメッキによって分断されている
金メッキです。
UNDER PLATING: NICKEL 1.5MICROMETER MINIMUM
DIVIDE INTO PARTS THE GOLD PLATING OF THE CONTACT AND THE TAIL PART BY THE NICKEL PLATING.
- 金具 FITTING NAIL
錫メッキ 1.0マイクロメートル以上
TIN PLATING 1.0MICROMETER MINIMUM
下地メッキ: ニッケルメッキ 1.0マイクロメートル以上
UNDER PLATING: NICKEL 1.0MICROMETER MINIMUM
- △ (全極数/2) = 偶数の場合に適用。
APPLY FOR (CIRCUIT/2)=EVEN.
- 嵌合相手: 55909シリーズ
MATE WITH: 55909 SERIES.

17.5	15.6	19.1	500837-0873	80
15.5	13.6	17.1	500837-0773	70
13.5	11.6	15.1	500837-0673	60
11.5	9.6	13.1	500837-0573	50
9.5	7.6	11.1	500837-0473	40
8.3	6.4	9.9	500837-3473	34
7.5	5.6	9.1	500837-0373	30
5.9	4.0	7.5	500837-2273	22
5.5	3.6	7.1	500837-0273	20
3.9	2.0	5.5	500837-9973	12
C	B	A	MATERIAL No.	CKT.

REVISED EC NO: J2008-0374 DRWN: AOYAGI 2007/08/23 CHKD: TOYODA 2007/08/23 APPR: NUKITA 2007/08/23	GENERAL TOLERANCES (UNLESS SPECIFIED)	DIMENSION STYLE MM ONLY	500837-xx73	MODEL NO.
	10 UNDER ± ---	DRAWN BY DATE M. NABE I '05/04/20	SCALE ---	DESIGN UNITS METRIC
	10 OVER 30 UNDER ± ---	CHECKED BY DATE K. TOYODA '05/04/20	THIRD ANGLE PROJECTION	
	30 OVER ± ---	APPROVED BY DATE N. UKITA '05/04/20	7.0 0.4 B-TO-B CONN REC HSG ASSY FOR CHECKER	
ANGULAR ± --- °	MATERIAL NO.	SEE TABLE	MOLEX INCORPORATED	
DRAFT WHERE APPLICABLE MUST REMAIN WITHIN DIMENSIONS	SIZE A3	THIS DRAWING CONTAINS INFORMATION THAT IS PROPRIETARY TO MOLEX INCORPORATED AND SHOULD NOT BE USED WITHOUT WRITTEN PERMISSION	DOCUMENT NO. SD-500837-003	SHEET NO. 1 OF 2

10 9 8 7 6 5 4 3 2 1

F

E

D

C

B

A

F

E

D

C

B

A

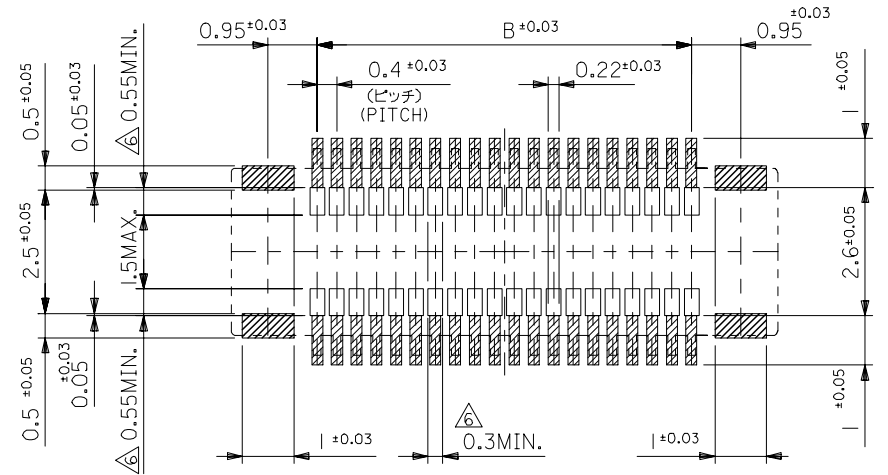
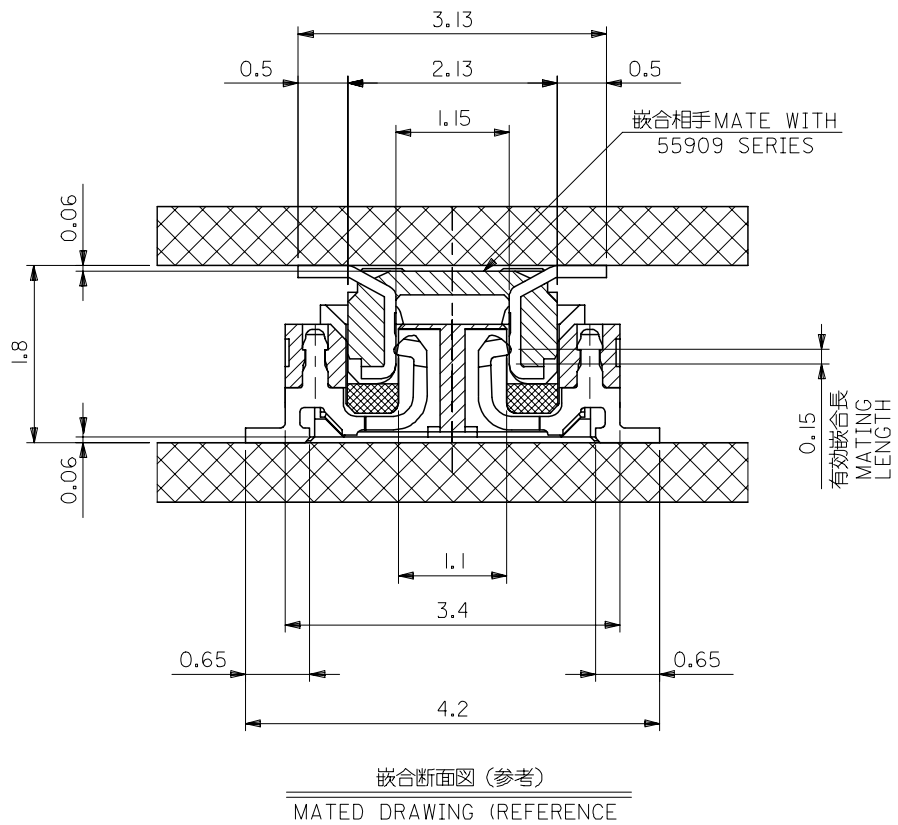

REVISED	DESCRIPTION
EC NO: J2008-0374	2007/08/23
DRWN: AOYAGI	2007/08/23
CHKD: TOYODA	2007/08/23
APPR: NUKITA	2007/08/23

GENERAL TOLERANCES (UNLESS SPECIFIED)	
10 UNDER	± ---
10 OVER 30 UNDER	± ---
30 OVER	± ---
ANGULAR	± --- °
DRAFT WHERE APPLICABLE MUST REMAIN WITHIN DIMENSIONS	

DIMENSION STYLE	
MM ONLY	
DRAWN BY	DATE
M. NABE I	'05/04/20
CHECKED BY	DATE
K. TOYODA	'05/04/20
APPROVED BY	DATE
N. UKITA	'05/04/20
MATERIAL NO.	
SEE TABLE	
SIZE	
A3	

500837-xx73		MODEL NO.
SCALE	DESIGN UNITS	THIRD ANGLE PROJECTION
---	METRIC	
TITLE		
0.4 B-TO-B CONN REC HSG ASSY FOR CHECKER		
MOLEX INCORPORATED		
DOCUMENT NO.		SHEET NO.
SD-500837-003		2 OF 2

NOTES

- 製品詳細寸法については製品単体図面を参照下さい。
RE DETAILED DIMENSION, SEE PRODUCT DRAWING.
- 梱包数量：2500個/リール
NUMBER OF CONNECTORS : 2500PCS/REEL
- リードテープ長さ LEAD TAPE LENGTH
20PCS. MIN. トップテープ接着部 (空エンボス)
TOP TAPE BONDED PART. (EMPTY)
部品挿入部 COMPONENT SUPPLIER
末端部 (空部) TAIL PART (EMPTY)
400 MIN. 40 MIN.
- 材料 MATERIAL
キャリアテープ (CARRIER TAPE) : ポリプロピレン (POLYPROPYLENE)
トップテープ (TOPTAPE) : PET , PE , PEF
リール (REEL) : ポリスチレン (PS) <リサイクル材を含む>
POLYSTYRENE (PS) <RECYCLE MATERIAL CONTAINED>
- ELV及びRoHS適合品。
ELV AND RoHS COMPLIANT.

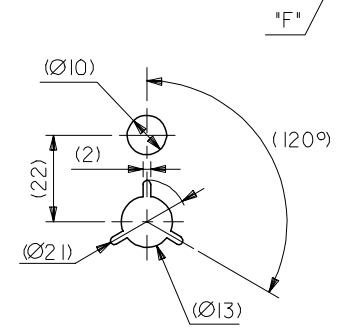
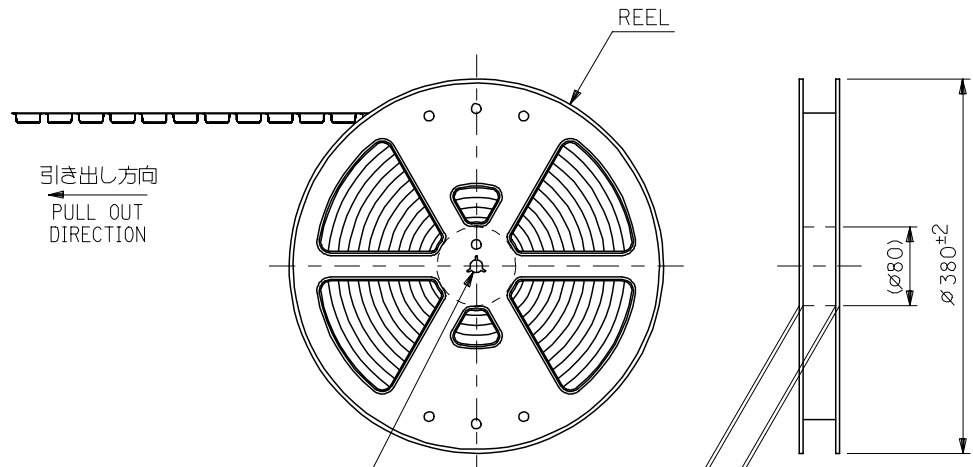

DETAIL "F"

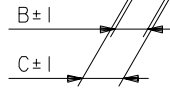

REVISED EC NO: J2008-0374 DRAWN: AOYAGI 2007/08/23 CHKD: TOYODA 2007/08/23 APPR: NUKITA 2007/08/23	DESCRIPTION	GENERAL TOLERANCES (UNLESS SPECIFIED)		DIMENSION STYLE MM ONLY		500837-xx74		MODEL NO.		
		10 UNDER	± ---	DRAWN BY M. NABEI	DATE '05/04/20	SCALE ---	DESIGN UNITS METRIC	THIRD ANGLE PROJECTION		
		10 OVER 30 UNDER	± ---	CHECKED BY K. TOYODA	DATE '05/04/20	TITLE 0.4 B-TO-B CONN REC HSG ASSY FOR CHECKER				
		30 OVER	± ---	APPROVED BY N. UKITA	DATE '05/04/20					
ANGULAR ± --- °		DRAFT WHERE APPLICABLE MUST REMAIN WITHIN DIMENSIONS		MATERIAL NO. SEE TABLE		DOCUMENT NO. SD-500837-004		SHEET NO. 1 OF 3		
SIZE A3		THIS DRAWING CONTAINS INFORMATION THAT IS PROPRIETARY TO MOLEX INCORPORATED AND SHOULD NOT BE USED WITHOUT WRITTEN PERMISSION								

10 9 8 7 6 5 4 3 2 1

F

E

D

C

B

A

F

E

D

C

B

A

引き出し方向
PULL OUT
DIRECTION

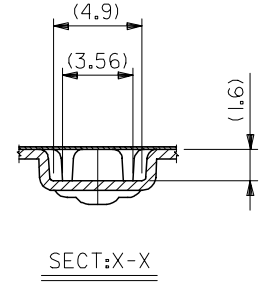
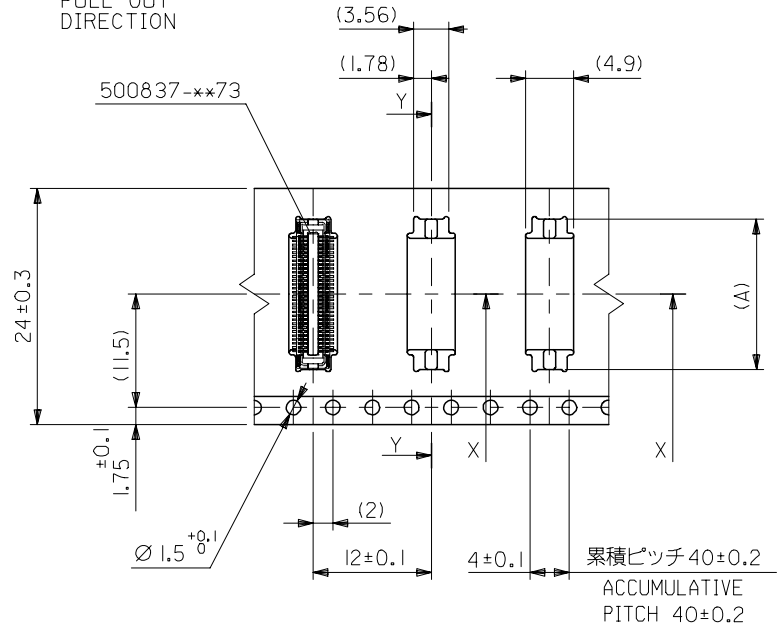
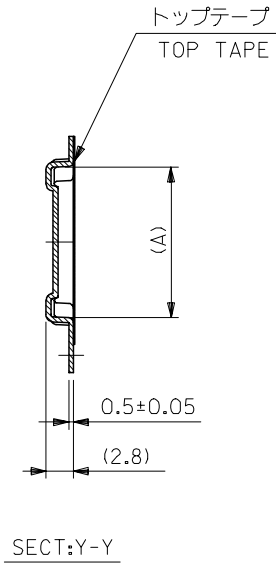

24mm幅キャリアテープ
24mm WIDTH CARRIER TAPE

24	29.4	25.4	15.26	500837-0674	60
			13.26	500837-0574	50
			11.26	500837-0474	40
			10.06	500837-3474	34
			9.26	500837-0374	30
			7.66	500837-2274	22
			7.26	500837-0274	20
5.66	500837-9974	12			
キャリアテープ幅 CARRIER TAPE WIDTH	C	B	(A)	MATERIAL NO.	極数 CKT.

REVISED EC NO: J2008-0374 DRWN: AOHYAGI 2007/08/23 CHKD: TOYODA 2007/08/23 APPR: NUKITA 2007/08/23	GENERAL TOLERANCES (UNLESS SPECIFIED)		DIMENSION STYLE MM ONLY		SCALE ---	DESIGN UNITS METRIC	MODEL NO. THIRD ANGLE PROJECTION	
	10 UNDER	± ---	DRAWN BY M. NABE I	DATE '05/04/20	TITLE 0.4 B-TO-B CONN REC HSG ASSY FOR CHECKER			
	10 OVER 30 UNDER	± ---	CHECKED BY K. TOYODA	DATE '05/04/20				
	30 OVER	± ---	APPROVED BY N. UKITA	DATE '05/04/20				
	ANGULAR	± --- °	MATERIAL NO. SEE TABLE		DOCUMENT NO. SD-500837-004		SHEET NO. 2 OF 3	
DRAFT WHERE APPLICABLE MUST REMAIN WITHIN DIMENSIONS		SIZE A3		THIS DRAWING CONTAINS INFORMATION THAT IS PROPRIETARY TO MOLEX INCORPORATED AND SHOULD NOT BE USED WITHOUT WRITTEN PERMISSION				

10 9 8 7 6 5 4 3 2 1

F

E

D

C

B

A

F

E

D

C

B

A

引き出し方向
PULL OUT
DIRECTION

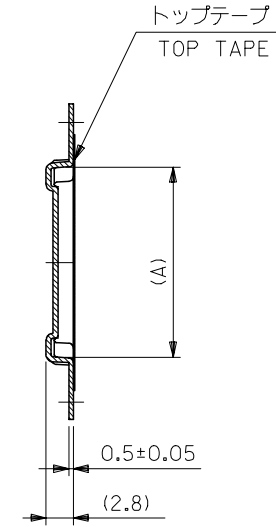

SECT:Y-Y

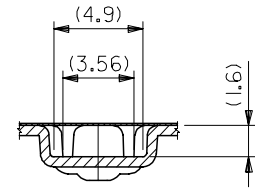
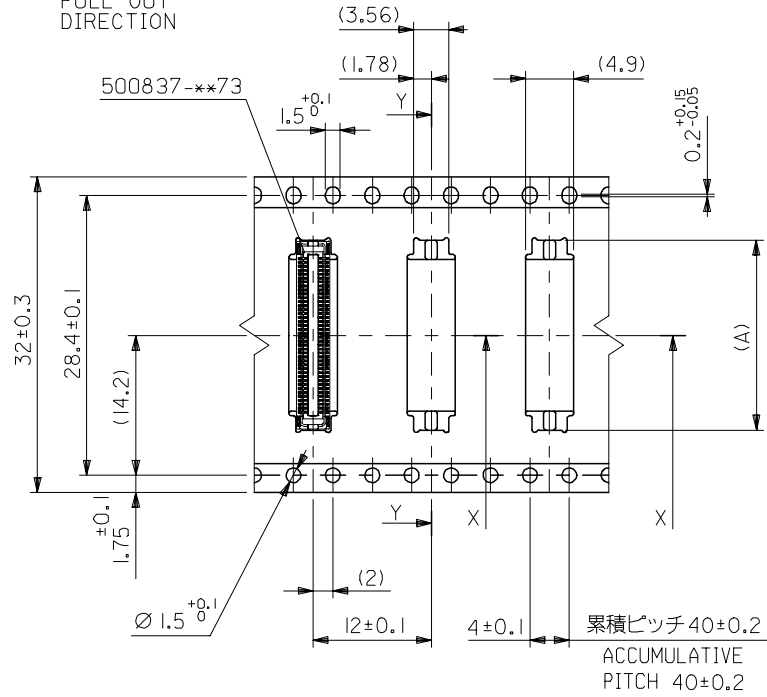

SECT:X-X

32mm幅キャリアテープ
32mm WIDTH CARRIER TAPE

32	37.4	33.4	19.26	500837-0874	80
キャリアテープ幅 CARRIER TAPE WIDTH	C	B	(A)	MATERIAL NO.	極数 CKT.

REVISED EC NO: J2008-0374 DRWN: AOYAGI CHKD: TOYODA APPR: NUKITA	DESCRIPTION 2007/08/23 2007/08/23 2007/08/23	GENERAL TOLERANCES (UNLESS SPECIFIED)		DIMENSION STYLE MM ONLY		SCALE ---		DESIGN UNITS METRIC		THIRD ANGLE PROJECTION	
		10 UNDER	± ---	DRAWN BY M. NABE I	DATE '05/04/20	TITLE 0.4 B-TO-B CONN REC HSG ASSY FOR CHECKER					
		10 OVER 30 UNDER	± ---	CHECKED BY K. TOYODA	DATE '05/04/20						
		30 OVER	± ---	APPROVED BY N. UKITA	DATE '05/04/20						
ANGULAR ± --- °		DRAFT WHERE APPLICABLE MUST REMAIN WITHIN DIMENSIONS		MATERIAL NO. SEE TABLE		DOCUMENT NO. SD-500837-004		MOLEX INCORPORATED			
SIZE A3		THIS DRAWING CONTAINS INFORMATION THAT IS PROPRIETARY TO MOLEX INCORPORATED AND SHOULD NOT BE USED WITHOUT WRITTEN PERMISSION									