

CATIA V5

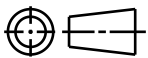

Revision Level			Revision Record	Changed	Date	Approved	Date
Drawing	State	Part					
01.1	Design Release	A	SEE ECN# 013217	CJR	08/05/15	SJA	08/05/15

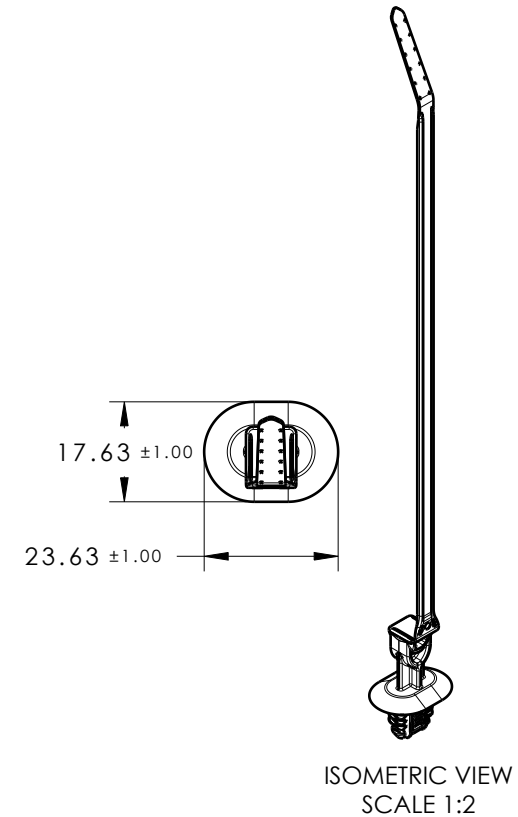
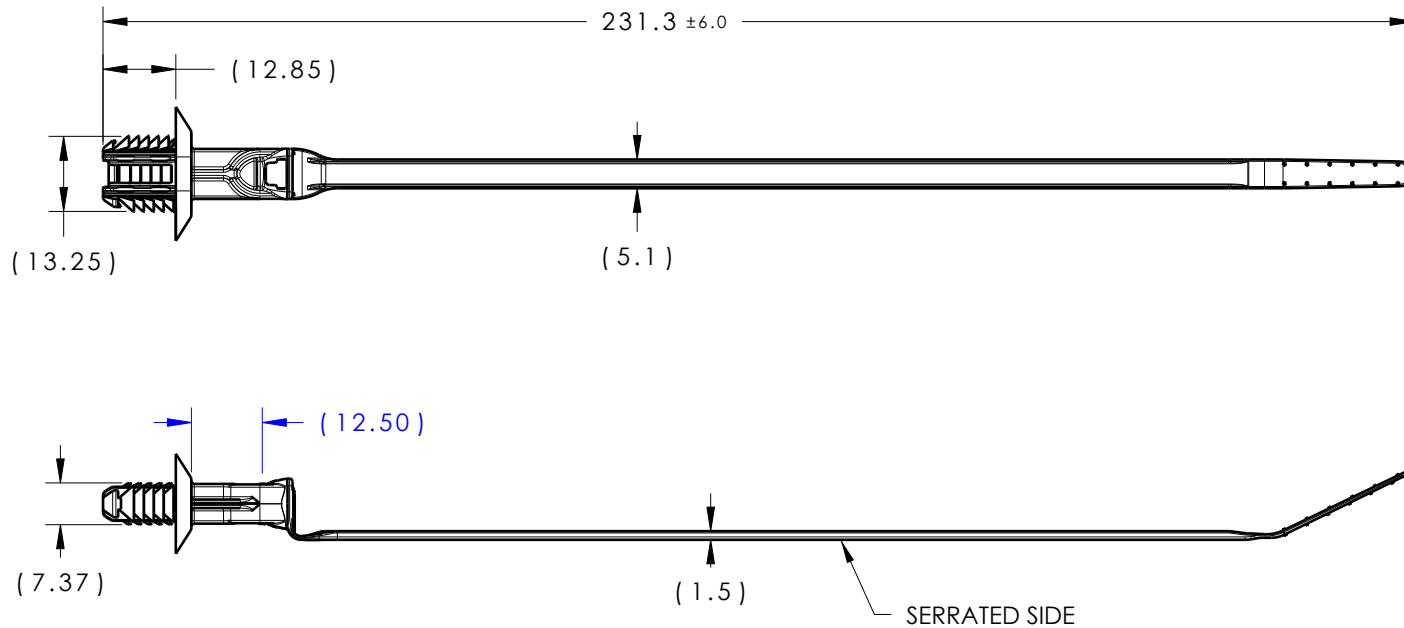

REFERENCE:

PERFORMANCE REQUIREMENTS AT DRY AS MOLDED:

1. FIR TREE PUSH IN FORCE: 45 NEWTONS (10 LBS) MAX IN EACH APPLICABLE OVAL HOLE SIZE AND A PLATE THICKNESS OF 1.8mm.
2. FIR TREE PULL OUT FORCE: 110 NEWTONS (25 LBS) MIN IN EACH APPLICABLE OVAL HOLE SIZE AND A PLATE THICKNESS OF 1.8mm.
3. SHEET METAL THICKNESS RANGE: 0.60mm - 6.75mm
4. APPLICABLE OVAL HOLE SIZES:
 - A. 6.2 X 12.2mm
 - B. 6.5 X 12.5mm
 - C. 6.5 X 13.0mm
 - D. 7.0 X 12.0mm
5. CABLE TIE TENSILE STRENGTH: 220 NEWTONS (50 LBS)
6. BUNDLE RANGE: 2.0mm TO 50mm

Material PA66HIRHS COLOR: BLACK	Units millimeters Tolerance defined on each dimension	The copyright of this drawing is reserved by HellermannTyton. It is issued on condition that it is not reproduced, copied or disclosed to a third party, either wholly or in part, without the consent of HellermannTyton.	Drawn	CJR	04/23/14	Article/Type-No	T50ROSFTOVAL12.5SO	Scale	3:4
			Approved	SJA	04/23/14	Title	12.5mm STAND OFF CABLE TIE WITH FTOVAL FIR TREE	Project Number	13-0226
			HellermannTyton North America Email: corp@htamericas.com Web: www.hellermann.tyton.com			Drawing-No	13-0226-021-CSU	PRODUCTION Phase	Format
		01.1				Sheet	1/1		