

THIS DRAWING IS UNPUBLISHED. RELEASED FOR PUBLICATION
 © COPYRIGHT - By - ALL RIGHTS RESERVED.

LOC	DIST	REVISIONS			
P	LTR	DESCRIPTION	DATE	DWN	APVD
AF	50	F1	REVISED PER ECR-20-009164	20JUL2020	MK DH

- 1 CONTINUOUS STRIP ON REELS
- 2 WIRE SIZE IS 6,000-10,000 CMS [12-10] AWG
- 3 INSULATION RANGE IS 2.79-6.73 [.110-.265] DIA
- 4 MATING TAB THK IS 0.84-0.76 [.033-.030].
- 5 PRELIMINARY - NOT FOR PRODUCTION

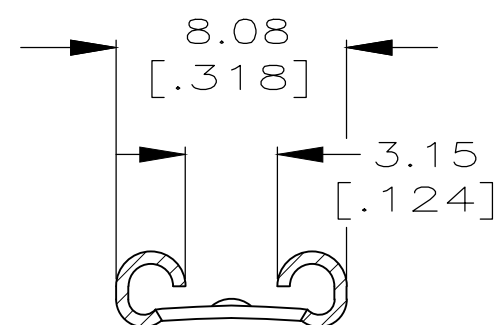
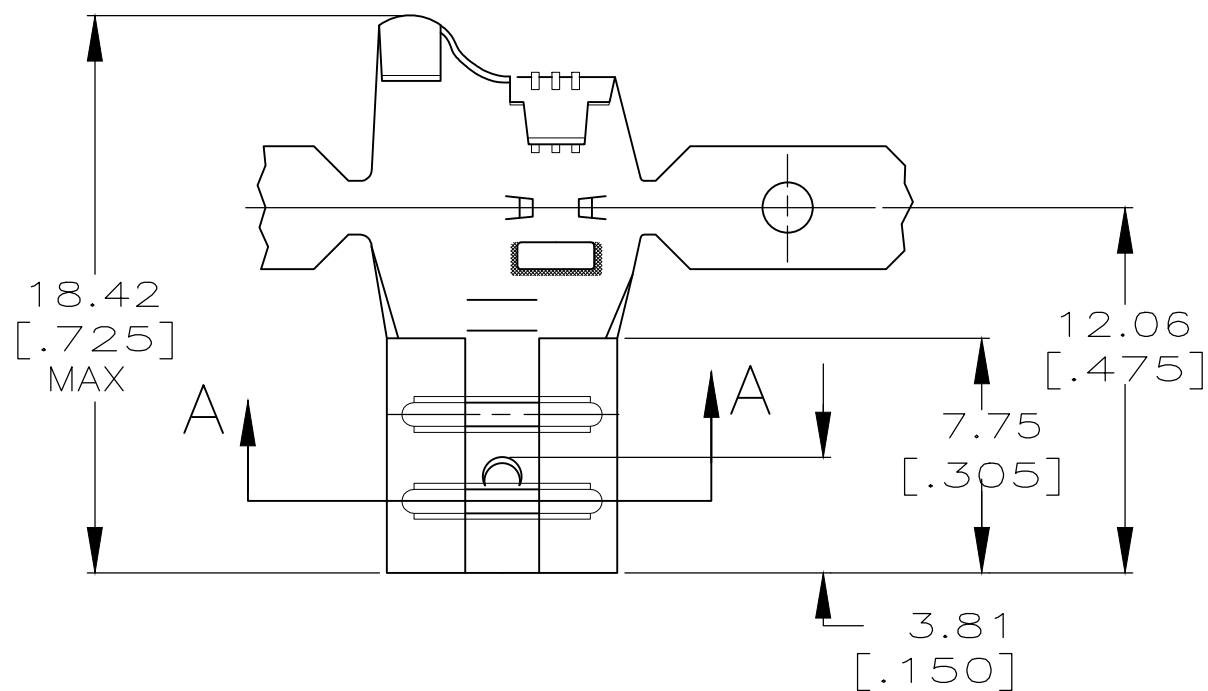

SECTION A-A
SCALE 10:1

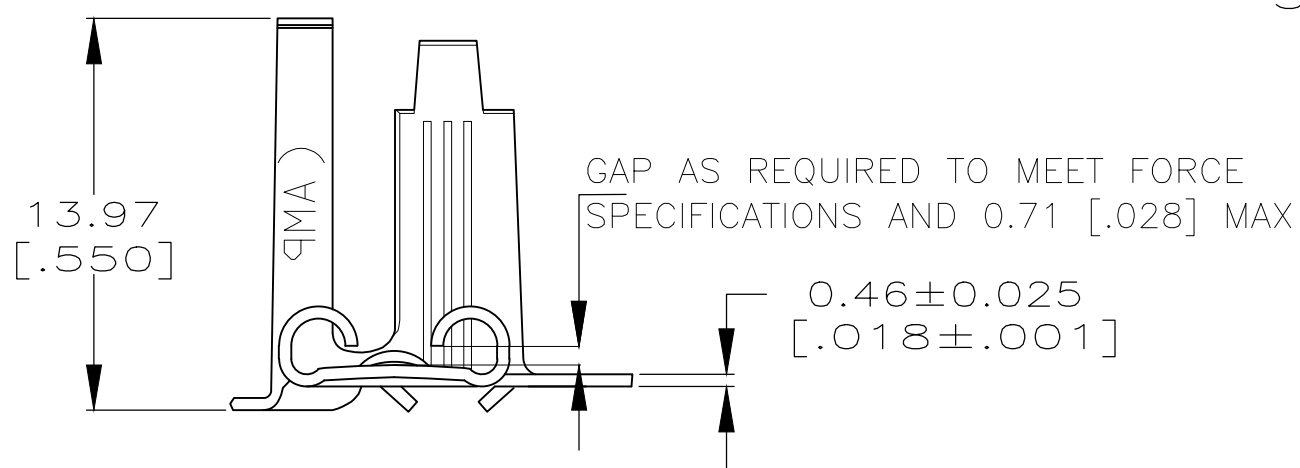

0.002032 [.000080] MIN TIN	5 63617-2
-	63617-1
FINISH	PART NO.

THIS DRAWING IS A CONTROLLED DOCUMENT.		DWN	JR RUTH	8/15/91	STE TE Connectivity												
DIMENSIONS: mm [INCHES]		CHK	P FORTNEY	8/15/91													
TOLERANCES UNLESS OTHERWISE SPECIFIED:		APVD	C MEYERS	8/15/91													
<table border="0"> <tr><td>0 PLC</td><td>± -</td></tr> <tr><td>1 PLC</td><td>± -</td></tr> <tr><td>2 PLC</td><td>± 0.25 [.010]</td></tr> <tr><td>3 PLC</td><td>± -</td></tr> <tr><td>4 PLC</td><td>± -</td></tr> <tr><td>ANGLES</td><td>± -</td></tr> </table>		0 PLC	± -	1 PLC		± -	2 PLC	± 0.25 [.010]	3 PLC	± -	4 PLC	± -	ANGLES	± -	PRODUCT SPEC	-	NAME
0 PLC	± -																
1 PLC	± -																
2 PLC	± 0.25 [.010]																
3 PLC	± -																
4 PLC	± -																
ANGLES	± -																
MATERIAL	BRASS	FINISH	SEE TABLE	WEIGHT	-												
CUSTOMER DRAWING		SIZE	A3	CAGE CODE	00779												
SCALE		4:1	DRAWING NO	C-63617	RESTRICTED TO	-											
SHEET		1 OF 1	REV	F1													