

THIS DRAWING IS UNPUBLISHED
 RELEASED FOR PUBLICATION 2018
 © COPYRIGHT 2012 BY TE CONNECTIVITY ALL RIGHTS RESERVED.

| REVISIONS | | | | | |
|-----------|-----|-----------------------------|-----------|-----|------|
| P | LTR | DESCRIPTION | DATE | DWN | APVD |
| | NC | NEW RELEASE PER E.O. P21296 | 13FEB2012 | JA | RDR |
| | A | REVISED PER E.O. P21378 | 08JUN2012 | JA | RDR |
| | B | REVISED PER PCN E-18-012207 | 31JUL2018 | JA | DM |
| | B1 | REVISED PER PCN E-19-018080 | 19NOV2019 | MK | DM |

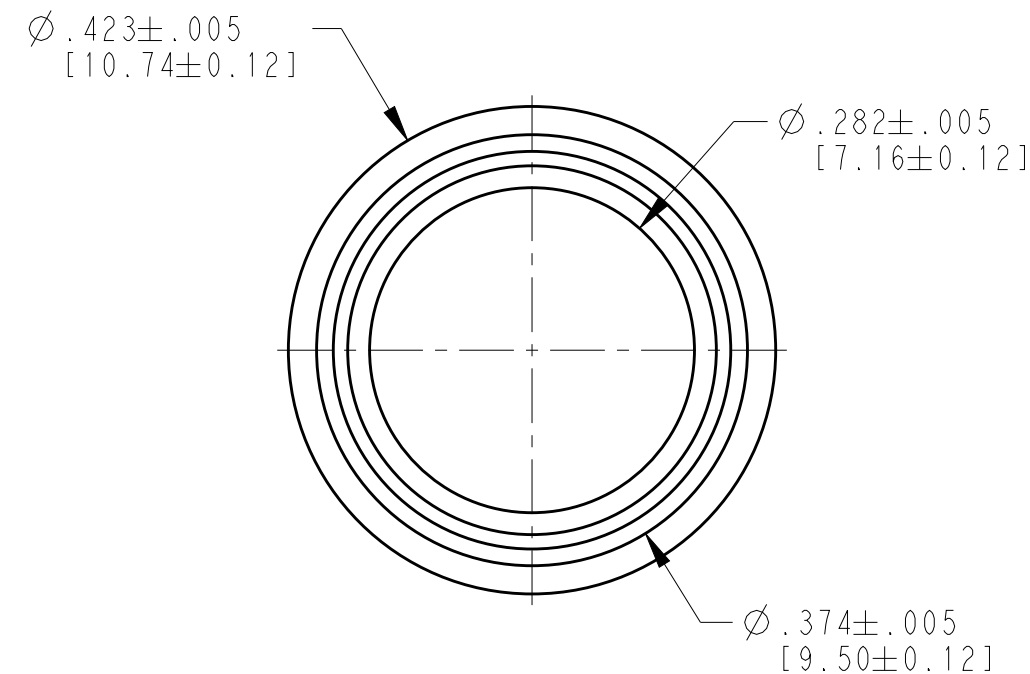
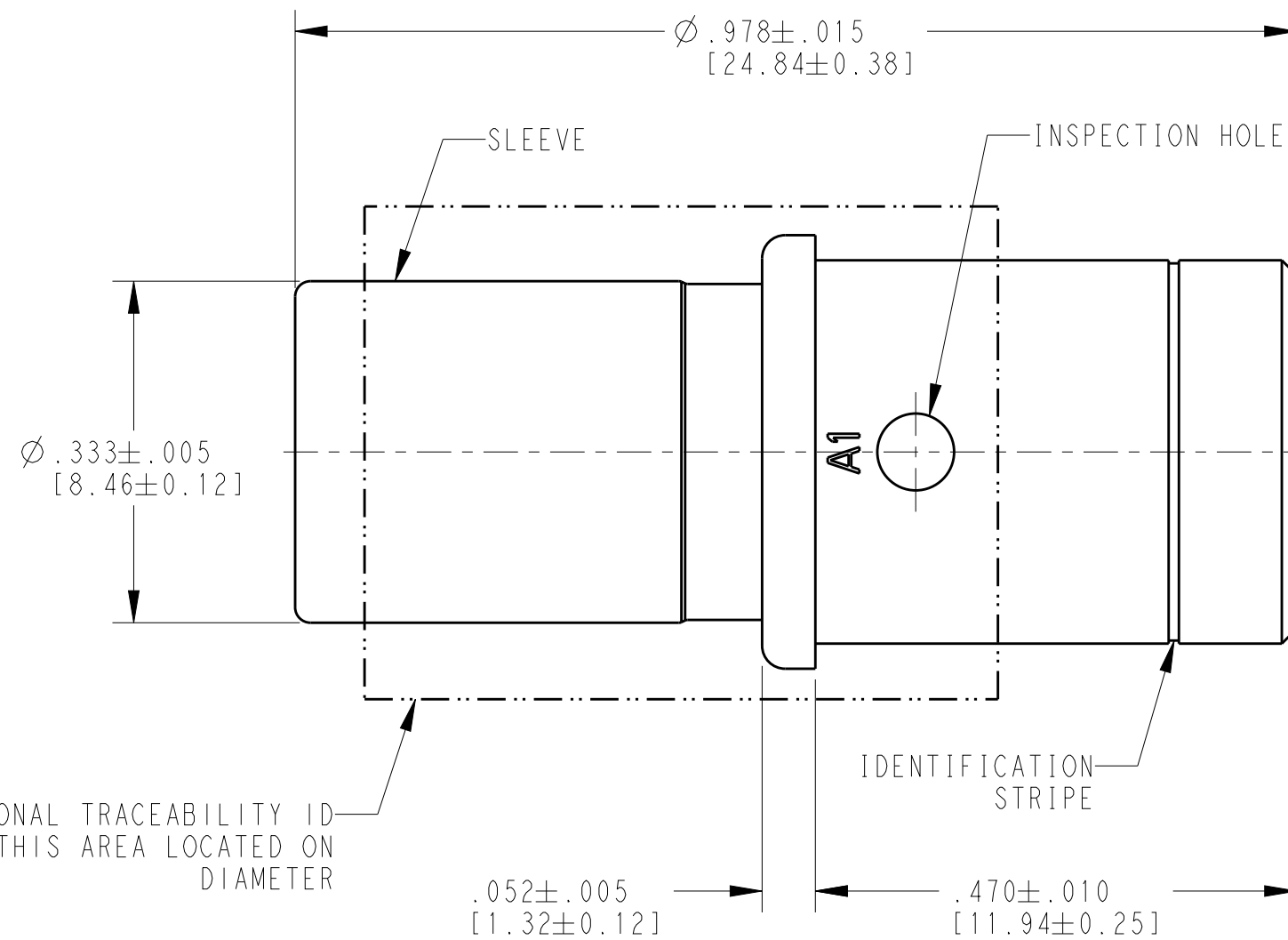

OPTIONAL TRACEABILITY ID
 IN THIS AREA LOCATED ON
 DIAMETER

| TE INTERNAL PN | DEUTSCH PN | PLATING |
|----------------|----------------|---------|
| 5962-203-04141 | 5962-203-04141 | NICKEL |
| 5962-203-0431 | 5962-203-0431 | GOLD |

B1 3. SEE APPLICATION SPECIFICATION 114-151004 FOR CRIMP TOOLS AND WIRE RANGE.

2. CONSULT FACTORY WHEN USING CONTACT OTHER THAN -C038 MODIFICATION.

B1 1. DELETED.

NOTES: UNLESS OTHERWISE SPECIFIED

THIS DRAWING IS A CONTROLLED DOCUMENT.

| DIMENSIONS: INCHES [mm] | TOLERANCES UNLESS OTHERWISE SPECIFIED: |
|----------------------------|---|
| | 0 PLC ± 1 PLC ± 2 PLC ± 3 PLC ± 4 PLC ± ANGLES ± |

MATERIAL FINISH

| | | |
|------------------|-------------|-----------|
| DWN | J. APOSTOL | 09FEB2012 |
| CHK | R. LEFFERTS | 31MAY2012 |
| APVD | D. MEYER | 01JUN2012 |
| PRODUCT SPEC | 108-151004 | |
| APPLICATION SPEC | 114-151004 | |
| WEIGHT | 7.44g | |

STE TE Connectivity

NAME: SOCKET, SOLID SIZE 4, 4 AWG

| SIZE | CAGE CODE | DRAWING NO | RESTRICTED TO |
|------|-----------|---------------|---------------|
| A3 | 4AFU8 | 5962-203-04XX | - |

CUSTOMER DRAWING SCALE 6:1 SHEET 1 OF 1 REV B1