



American Opto Plus LED Corp.

L105L-LEPGBC-3I

4.0 x 2.0 x 1.6mm RGB with IC Side View SMD LED

PACKAGE OUTLINES

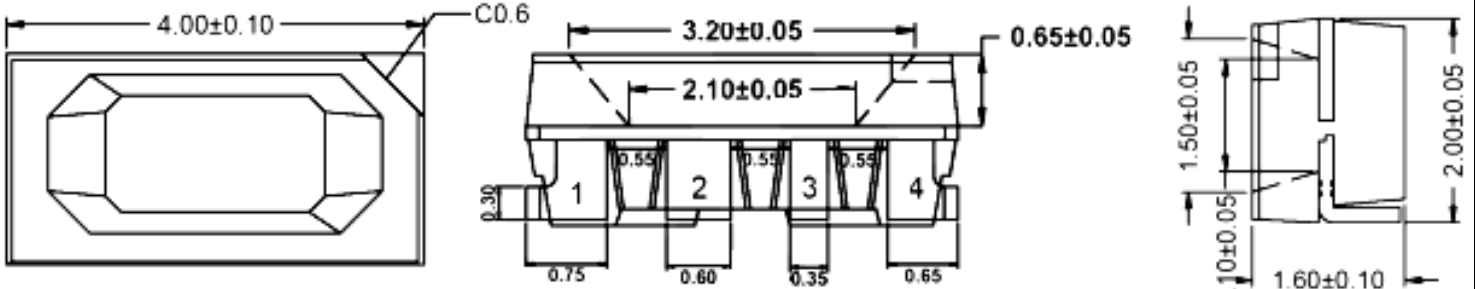

Note:

1. All dimensions are in millimeters.
2. Tolerance is ± 0.1 mm unless otherwise noted.

PIN CONFIGURATION

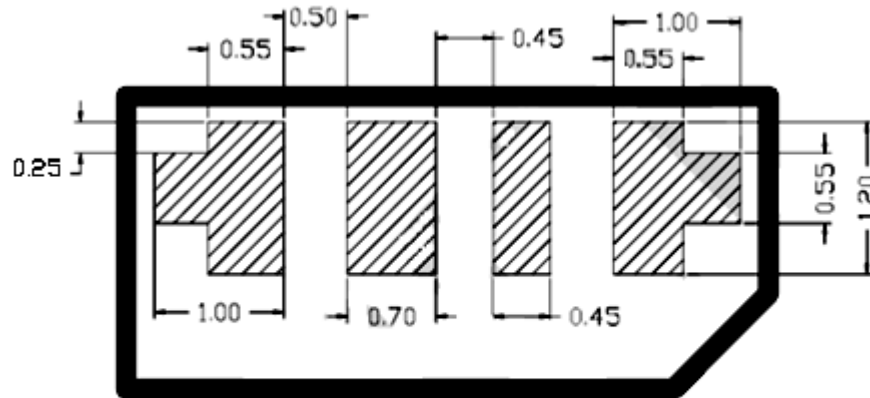

1 DIN 2 VDD 3 DOUT 4 GND

TOP VIEW

No.	Symbol	Function Description
1	DIN	Control Data Signal Input
2	VDD	Power Supply LED
3	DOUT	Control Data Signal Output
4	GND	Ground



American Opto Plus LED Corp.

L105L-LEPGBC-3I

4.0 x 2.0 x 1.6mm RGB with IC Side View SMD LED

ABSOLUTE MAXIMUM RATINGS

Ta=25°C/VSS=0V

Parameter	Symbol	Range	Unit
Power Supply Voltage	VDD	+3.7~+5.5	V
Logic Input Voltage	V _{IN}	-0.5~VDD+5.5	V
Reverse Voltage	VR	12	V
Working Temperature	T _{opt}	-40~+85	°C
Storage Temperature	T _{stg}	-40~+85	°C
ESD Pressure (DM)	V _{ESD}	200	V
ESD Pressure (HBM)	V _{ESD}	2K	V

OPTICAL CHARACTERISTICS

12mA

Color	Luminance (mcd)	Luminous Flux (lm)	Dominant Wavelength (nm)
Red	240-450	0.7-1.4	620-630
Green	580-1050	2.4-3.8	520-530
Blue	160-320	0.5-1.0	460-470

Note: Wavelength will maintain increment of 10Nm for all colors.

ELECTRICAL PARAMETERS

Ta=-20-+70°C/VDD=4.5~5.5V/VSS=0V

Parameter	Symbol	Min	Typ	Max	Unit	Conditions
The chip supply voltage	VDD	--	5.2	--	V	--
The signal input flip threshold	V _{IH}	0.7*VDD	--	--	V	VDD=5.0V
	V _{IL}	--	--	0.3*VDD	V	
The frequency of PWM	FPWM	--	1.0	--	KHZ	--
Static power consumption	IDD	--	0.5	--	mA	--



American Opto Plus LED Corp.
L105L-LEPGBC-3I
4.0 x 2.0 x 1.6mm RGB with IC Side View SMD LED

DYNAMIC PARAMETERS

Parameter	Symbol	Min	Typ	Max	Unit	Test Conditions
The speed of data transmission	fDIN	--	800	--	KHZ	The duty ratio of 67% (data 1)
DOUT transmission delay	TPLH	--	67	--	ns	The earth load capacitance of the dout port is 30pf, and the signal transmission delay from DIN to dout
	TPHL	--	82	--	ns	
Out R/B Conversion Time	Tr	--	22	--	ns	IOUT R / B= 5mA, out R / B port connected with 200 Ω resistor to VDD in series, load capacitance to ground
	Tf	--	75	--	ns	
IOUT rise/drop time	Tr	--	18	--	ns	OUT g = 5mA, out g port is connected with 200 Ω resistor to VDD in series, and the load capacitance to ground is 30pf
	Tf	--	110	--	ns	



American Opto Plus LED Corp.

L105L-LEPGBC-3I

4.0 x 2.0 x 1.6mm RGB with IC Side View SMD LED

DYNAMIC PARAMETERS

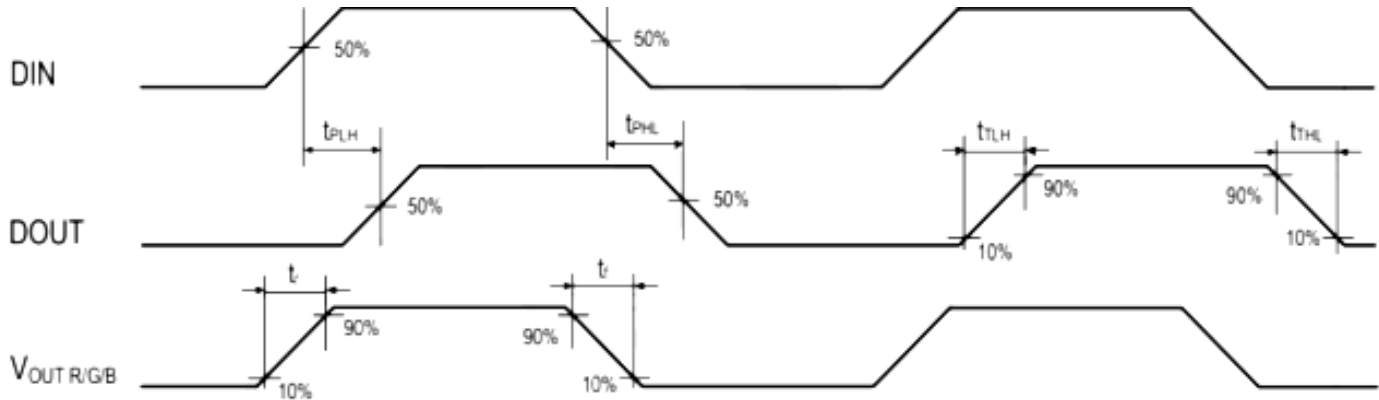

DATA TRANSMISSION TIME

Parameter	Description	Min	Standard Value	Max	Unit
T	Code Period	1.20	--	--	μs
T0H	0 code, high level time	0.2	0.3	0.4	μs
T0L	0 code, low level time	0.8	--	--	μs
T1H	1 code, high level time	0.7	0.9	1.0	μs
T1L	1 code, low level time	0.2	--	--	μs
Trst	reset code, low level time	200	--	--	μs

The protocol uses a unipolar zeroing code.

Each symbol must have a low level.

Each symbol in this protocol starts with a high level. The high time width determines the “0” or “1” code.

When writing programs, the minimum symbol period is 1.2 μs .

The high time of “0” code and “1” code should be in accordance with the stipulated range in the above table.

The low time requirement of “0” code and “1” code is less than 20 μs .



American Opto Plus LED Corp.

L105L-LEPGBC-3I

4.0 x 2.0 x 1.6mm RGB with IC Side View SMD LED

TIMING WAVEFORM (Ta=25°C)

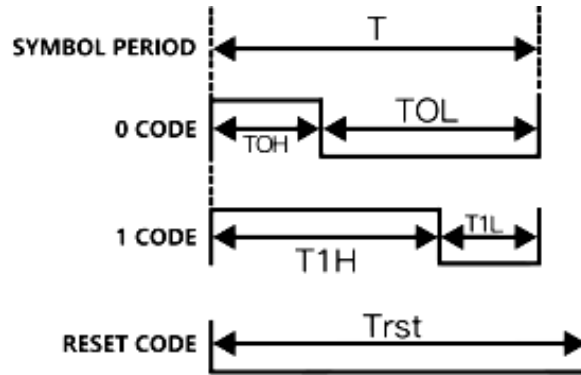

CONNECTION METHOD

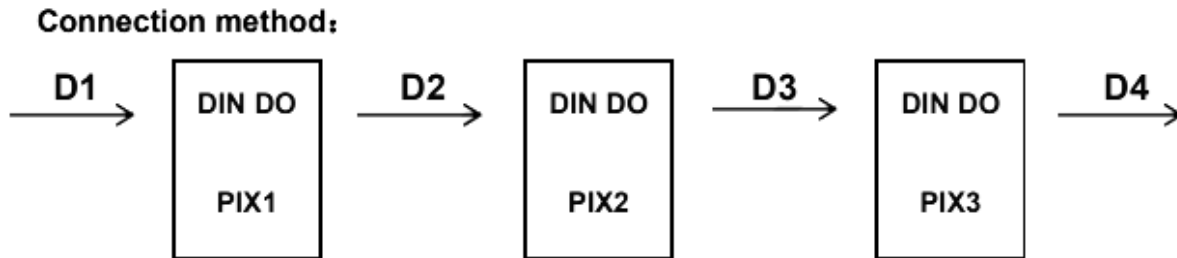

24BIT DATA STRUCTURE (Ta=25°C)

G7	G6	G5	G4	G3	G2	G1	G0	R7	R6	R5	R4
R3	R2	R1	R0	B7	B6	B5	B4	B3	B2	B1	B0



American Opto Plus LED Corp.

L105L-LEPGBC-3I

4.0 x 2.0 x 1.6mm RGB with IC Side View SMD LED

TYPICAL APPLICATION CIRCUIT

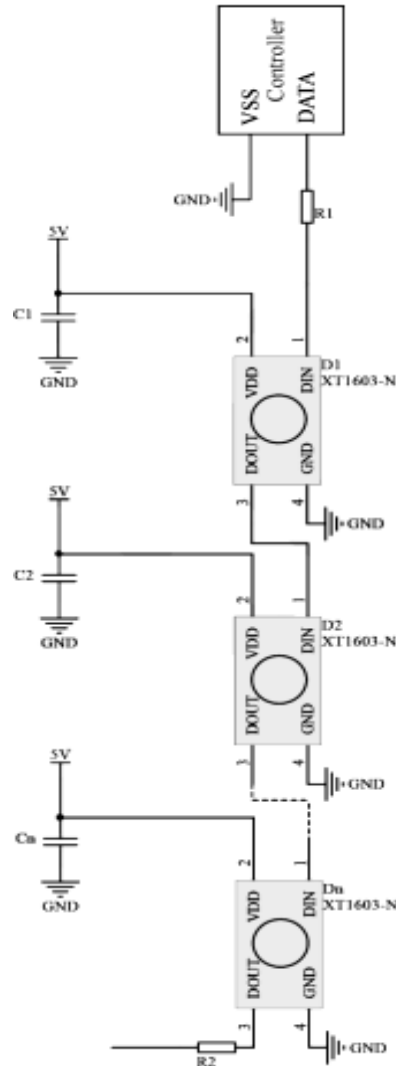

Note:

- In the application circuit, in order to prevent the instantaneous high voltage caused by the hot plug of the product during the test from damaging the internal signal input and output pins of the IC, the protection resistor should be connected in series at the signal input and output terminals.
- In addition, in order to make the IC chips work more stably, the decoupling capacitance between the beads is essential; Application 1: for flexible or rigid LED strip, the transmission distance between the lamp beads is short, it is recommended to connect the protection resistance at the input and output end in series, i.e. $R1=R2$, about 500 ohm.
- Application for module or general special- shaped products, lamp beads transmission distance is long, because of different wire and transmission distance, in the signal in time clock at both ends of the line on



American Opto Plus LED Corp.

L105L-LEPGBC-3I

4.0 x 2.0 x 1.6mm RGB with IC Side View SMD LED

grounding protection resistance will be slightly different.

CHARACTERISTIC CURVES

Thermal Pad Temperature vs. Relative Light Output

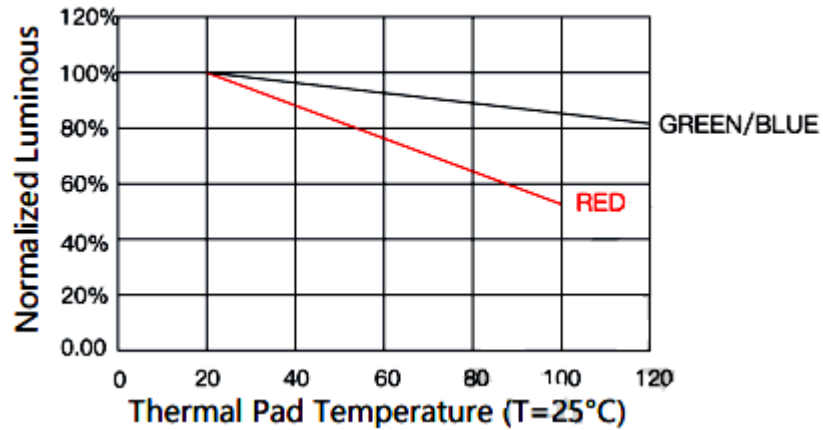

Wavelength Characteristics

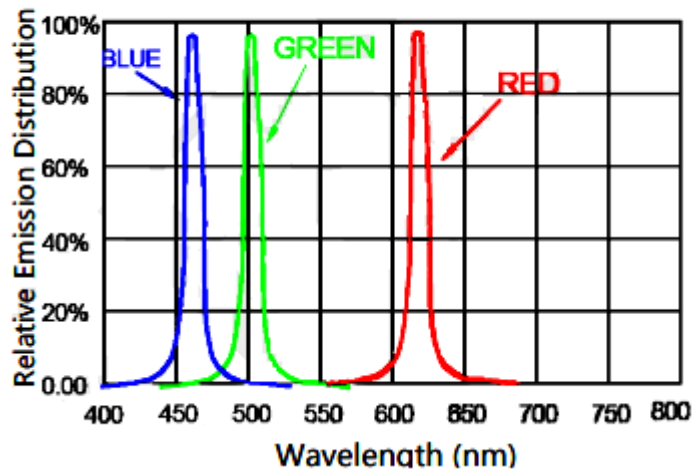

Typical Radiation Pattern 120°

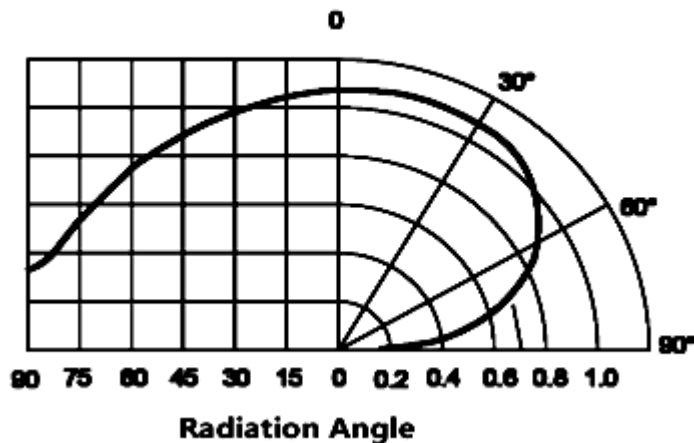



American Opto Plus LED Corp.
L105L-LEPGBC-3I
4.0 x 2.0 x 1.6mm RGB with IC Side View SMD LED

RELIABILITY TEST

Test Item	Test Condition	Reference
Temperature Cycle	-40°C~25°C~100°C~25°C 30min~5min~30min~5min 100 cycles	JEITA ED-4701 100 105
High Temp. Storage	Ta= +100°C 1000hrs	MIL-STD-883:1008 JIS C 7021: B- 10
Low Temp. Storage	Ta= -40°C 1000hrs	JIS C 7021: B-12
High Temp. High Humidity Storage	Ta=60°C RH=90% 1000hrs	MIL-STD-202:103B JIS C 7021: B- 11
Thermal Shock	100 ± 5°C ~ -40°C ± 5°C 15min~15min 100cycles	MIL-STD-202G
Solder Resistance Test	Tsld = 260°C , 10sec. 2 times	JEITA ED-4701 300 301
Normal Temp. Life Test	25°C, IF: Typical current, 1000hrs	JESD22-A 108D

CRITERIA FOR JUDGING THE DAMAGE

Project	Symbol	Test Conditions	Min	Max
Luminous Intensity	IV	DC=5V, Typical Current	Initial Data x 0.7	--
Resistance to Soldering Heat	--	DC=5V, Typical Current	No dead LEDs or obvious damage	



American Opto Plus LED Corp.
L105L-LEPGBC-3I
4.0 x 2.0 x 1.6mm RGB with IC Side View SMD LED

CAUTIONS

Dust & Cleaning:

- The surface of LED is packaged with silicone adhesive.
- Silicone resin plays a good protective role in the optical system and anti-aging properties of LED. However, silicon resin is soft and easy to stick to dust, so it is necessary to keep the working environment clean. Of course, there is a certain limit of dust on the LED surface, which will not affect the luminous intensity, but we should still avoid dust falling on the LED surface.
- Opening the bag is a priority, and components installed with LED should be stored in clean containers.
- When the surface of LED needs to be cleaned, if the solution such as trichloroethylene or acetone is used, the surface of LED will be dissolved and so on.
- Do not use soluble solution to clean the LED.
- Make sure whether it dissolves the LED before using any cleaning solution.
- Do not clean the LEDs by the ultrasonic. When it is absolutely necessary, the influence as ultrasonic cleaning on the LEDs depends on factors such as ultrasonic power.
- Before cleaning, a pre-test should be done to confirm whether any damage to the LEDs will occur.

Shipping and Storage:

- TOP SMD LED is a humidity sensor, the LED packaging in the aluminum bag is to avoid the LED in the transport and storage of moisture absorption, in the bag with a desiccant to absorb the moisture inside the bag.
- If the LED absorbs water vapor, then in the LED over reflow, in the high temperature state, into which the rapid expansion of gas vaporization and produce a greater internal stress, so that the material crack, layered or damaged bonding wire, Resulting in product failure.
- TOP SMD LED with a moisture-proof anti-static aluminum foil bag packaging, handling should avoid the process of squeezing, piercing the case of bags, and do the necessary anti-static protective measures; promise products on the line before the leak or broken, Please stop the use of direct use of the product.
- If moisture-proof aluminum foil bags have been opened, damaged, perforated can be returned to the original re-dehumidification, must not be on-line use; The humidity level of this product is LEVEL 5a.



American Opto Plus LED Corp.
L105L-LEPGBC-3I
4.0 x 2.0 x 1.6mm RGB with IC Side View SMD LED

MOISTURE PROOF LEVELS

Moisture proof level	Workshop life after packaging and unpacking	
	time	condition
LEVEL1	Unlimited	≤30°C/85 % RH
LEVEL2	1 year	≤30°C/60 % RH
LEVEL2a	4 weeks	≤30°C/60 % RH
LEVEL3	168 hours	≤30°C/60 % RH
LEVEL4	72 hours	≤30°C/60 % RH
LEVEL5	48 hours	≤30°C/60 % RH
LEVEL5a	24 hours	≤30°C/60 % RH
LEVEL6	Take out and use	≤30°C/60 % RH

ENVIRONMENTAL HUMIDITY

Environment humidity	Oven temperature	Baking time	Baking method
40%	70°C	24H	Remove from the electrostatic bag and bake and dehumidify with the reel
50%	70°C	48H	Remove from the electrostatic bag and bake and dehumidify with the reel
>60%	70°C	Ineffective dehumidification baking	
40%	130°C	6H	Baking and dehumidification in granular form.
50%	130°C	12H	Baking and dehumidification in granular form.



American Opto Plus LED Corp.
L105L-LEPGBC-3I
4.0 x 2.0 x 1.6mm RGB with IC Side View SMD LED

REFLOW SOLDERING CHARACTERISTICS

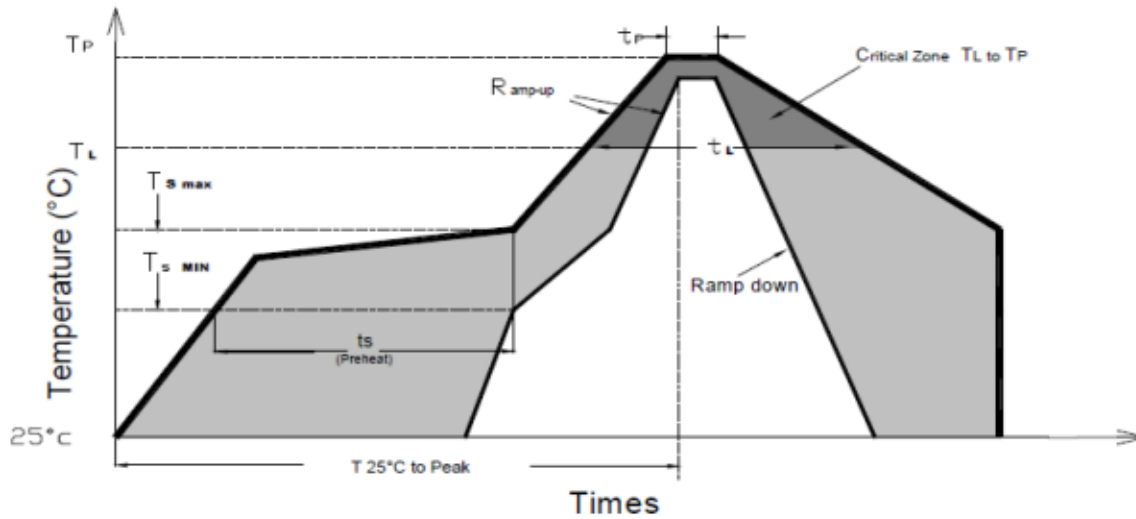

Profile Feature	Lead-Based Solder	Lead-Free Solder
Average Ramp-Up Rate	3°C/sec max	3°C/sec max
Preheat Temp Min	100°C	150°C
Preheat Temp Max	150°C	200°C
Preheat Time	60-120 seconds	60-180 seconds
Time maintained above: temp.	183°C	217°C
Time maintained above: time	60-150 seconds	60-150 seconds
Peak/classification temperature	215°C	240°C
Time within 5°C of actual peak temp.	<10 seconds	<10 seconds
Ramp-down rate	6°C/second max	6°C/second max
Time 25°C to peak temp.	<6 minutes max	<6 minutes max

Note:

Version 1.1 Date: 01/12/2022 Specifications are subject to change without notice.
 American Opto Plus LED Corp. 1206 E. Lexington Ave., Pomona CA 91766 Tel: 909-465-0080 Fax: 909-465-0130 www.aopled.com



American Opto Plus LED Corp.
L105L-LEPGBC-3I
4.0 x 2.0 x 1.6mm RGB with IC Side View SMD LED

1. All temperatures refer to topside of the package, measured on the package body surface.

HEAT GENERATION

- Thermal design of the end product is of paramount importance.
- Please consider the heat generation of the LED when making the system design.
- The coefficient of temperature increase per input electric power is affected by the thermal resistance of the circuit board and density of LED. Placement on the board, as well as components.
- It is necessary to avoid intense heat generation and operate within the maximum rating given in this specification.
- The operating current should be decided after considering the ambient maximum temperature of LEDs.

ELECTROSTATIC DISCHARGE AND SURGE CURRENT

- Electrostatic discharge (ESD) or surge current (EOS) may damage LED.
 - Precautions such as ESD wrist strap, ESD shoe strap or antistatic gloves must be worn whenever handling of LED.
- All devices, equipment and machinery must be properly grounded.
- It is recommended to perform electrical test to screen out ESD failures at final inspection.
 - It is important to eliminate the possibility of surge current during circuitry design.

MOISTURE PROOF PACKAGE

- Cannot take any responsibility for any trouble that is caused by using the LEDs at conditions exceeding our specifications.
- The LED light output is strong enough to injure human eyes.
- Precautions must be taken to prevent looking directly at the LEDs with unaided eyes for more than a few seconds.
- The formal specification must be exchanged and signed by both parties before large volume purchase begins.
- The appearance and specifications of the product may be modified for improvement without notice.