



MATERIAL

Glass-fibre reinforced polyamide based (PA) special technopolymer.

ROD SPHERICAL CAP

Polyamide-based self-lubricating technopolymer (PA).

STANDARD EXECUTIONS

- **BJT:** with threaded hole.
- **BJT-p:** with threaded pin.

FEATURES AND APPLICATIONS

BJT. rod ends are remarkably suitable for rotary, oscillating and linear movements even in particularly aggressive environments and when water or humidity, fine dusts, dirt, fabrics and machining residues are present.

The shaft rotary movement can take place directly on the inner diameter of the spherical cap, made of self-lubricating material.

Features of the technopolymer rod ends:

- totally corrosion resistant even in the presence of chemicals;
- high strength to saline mist;
- high mechanical strength to the applied loads;
- lightness combined with high-rigidity;
- maintenance free;
- compensation of possible misalignments;
- absorption of vibrations and transverse stresses;
- noise minimisation.



Conversion Table	
1 mm = 0,039 inch	
d1	
mm	inch
6	0.24
8	0.31
10	0.39
12	0.47
14	0.55

Resistance tests	Max static load under traction		Max transverse load	
	short term	continuous	short term	continuous
Description	[N]	[N]	[N]	[N]
BJT-M6	1400	700	400	200
BJT-M8	2100	1050	700	350
BJT-M10	3100	1550	800	400
BJT-M10x1.25	3100	1550	800	400
BJT-M12	3600	1800	900	450
BJT-M12x1.25	3600	1800	900	450
BJT-M14	4000	2000	1000	500
BJT-p-M6-36	1000	500	100	50
BJT-p-M8-42	1700	850	200	100
BJT-p-M10-48	2500	1250	300	150
BJT-p-M10x1.25-48	2500	1250	300	150
BJT-p-M12-54	2700	1350	400	200
BJT-p-M12x1.25-54	2700	1350	400	200
BJT-p-M14-61	3400	1700	700	350

The strength values are the result of lab tests carried out under room temperature (23°C).

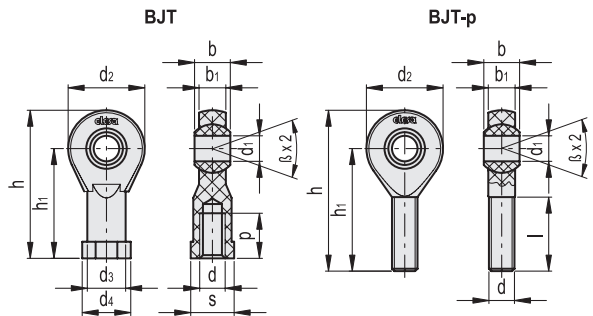

BJT.

METRIC

Code	Description	d	p	d1E10	d2	d3	d4	b	b1	h	h1	s	[Nm]*	[Nm]#	Min. thread tightening depth [mm]	Max. oscillation angle β	⚖
470001	BJT-M6	M6	12	6	20	10	13	9	7	40	30	11	1.5	10	8	29°	5
470011	BJT-M8	M8	16	8	24	13	16	12	9	48	36	14	10	12	11	25°	9
470021	BJT-M10	M10	20	10	30	15	19	14	10.5	58	43	17	15	20	13	25°	15
470022	BJT-M10x1.25	M10x1.25	20	10	30	15	19	14	10.5	58	43	17	6	20	13	25°	15
470031	BJT-M12	M12	22	12	34	18	22	16	12	67	50	19	20	30	15	25°	20
470032	BJT-M12x1.25	M12x1.25	22	12	34	18	22	16	12	67	50	19	15	30	15	25°	20
470041	BJT-M14	M14	25	14	38	20	25	19	13.5	76	57	22	25	35	17	25°	31

BJT-p

Code	Description	d	d1E10	d2	l	b	b1	h	h1	[Nm]*	[Nm]#	Min. thread tightening depth [mm]	Max. oscillation angle β	⚖
470101	BJT-p-M6-36	M6	6	20	21	9	7	46	36	0.5	10	15	29°	4
470111	BJT-p-M8-43	M8	8	24	25	12	9	55	43	2	12	18	25°	7
470121	BJT-p-M10-48	M10	10	30	28	14	10.5	63	48	5	20	20	25°	13
470122	BJT-p-M10x1.25-48	M10x1.25	10	30	28	14	10.5	63	48	3	20	20	25°	13
470131	BJT-p-M12-54	M12	12	34	32	16	12	71	54	6	30	22	25°	18
470132	BJT-p-M12x1.25-54	M12X1.25	12	34	32	16	12	71	54	6	30	22	25°	18
470141	BJT-p-M14-61	M14	14	38	36	19	13.5	80	61	12	35	25	25°	26

* Max. thread tightening torque

Max. cap tightening torque