

REVISION AB

NOTES:

1. Ⓢ REPRESENTS A CRITICAL DIMENSION.
2. MAXIMUM ALLOWABLE BOW: .005 [0.13]IN/IN.
3. MAXIMUM PIN VARIATIONS BETWEEN ANY TWO PINS: .010 [0.25].
4. MINIMUM TERMINAL PUSHOUT FORCE: 2 LBS.
5. MAXIMUM PIN ROTATION IN BODY: 2°.
6. MAXIMUM CUT FLASH .010 [0.25].
7. TUBE POSITIONS -07 THRU -50. POSITIONS -01 THRU -06 ARE TO BE LAYER PACKAGED.
8. FOR -D, USE DWM-50-D WHEN RAN ON BOARD STACKER AUTOMATION, HTMS-50-D FOR ALL OTHER PROCESSES. FOR -S, USE HTMS-50-S.
9. FOR -L, -S & -G PLATING, GOLD WILL BE ON CONTACT AREA.
10. FOR ADDED MECHANICAL STABILITY, SAMTEC RECOMMENDS MECHANICAL BOARD SPACERS BE USED IN APPLICATIONS WITH GOLD OR SELECTIVE GOLD PLATED CONNECTORS. CONTACT IPG@SAMTEC.COM FOR MORE INFORMATION.

DO NOT SCALE FROM THIS PRINT

HDWM-XX-XX-XX-X-XXX-XXX

NO OF POS
(-01 THRU -50)
LEAD STYLE
SEE TABLE 1

OPTION
POLARIZING SPECIFICATION
XXX INDICATES POS. TO BE OMITTED
(SEE FIG 1 AND 2)

PLATING SPECIFICATION

- G: 10μ" SELECTIVE GOLD IN CONTACT AREA, 3μ" SELECTIVE GOLD ON TAIL.
- T: MATTE TIN ON ENTIRE PIN.
- S: 30μ" SELECTIVE GOLD IN CONTACT AREA, MATTE TIN ON TAIL.
- TM: MATTE TIN ON ENTIRE PIN.
- SM: 30μ" SELECTIVE GOLD IN CONTACT AREA, MATTE TIN ON TAIL.
- L: 10μ" SELECTIVE GOLD IN CONTACT AREA, MATTE TIN ON TAIL.

BOARD SPACE

-XXX: BOARD SPACE
MAX = "L" - .120[3.05]

BODY SPECIFICATION

-S: SINGLE (USE HTMS-50-S)
-D: DOUBLE (USE HTMS-50-D)

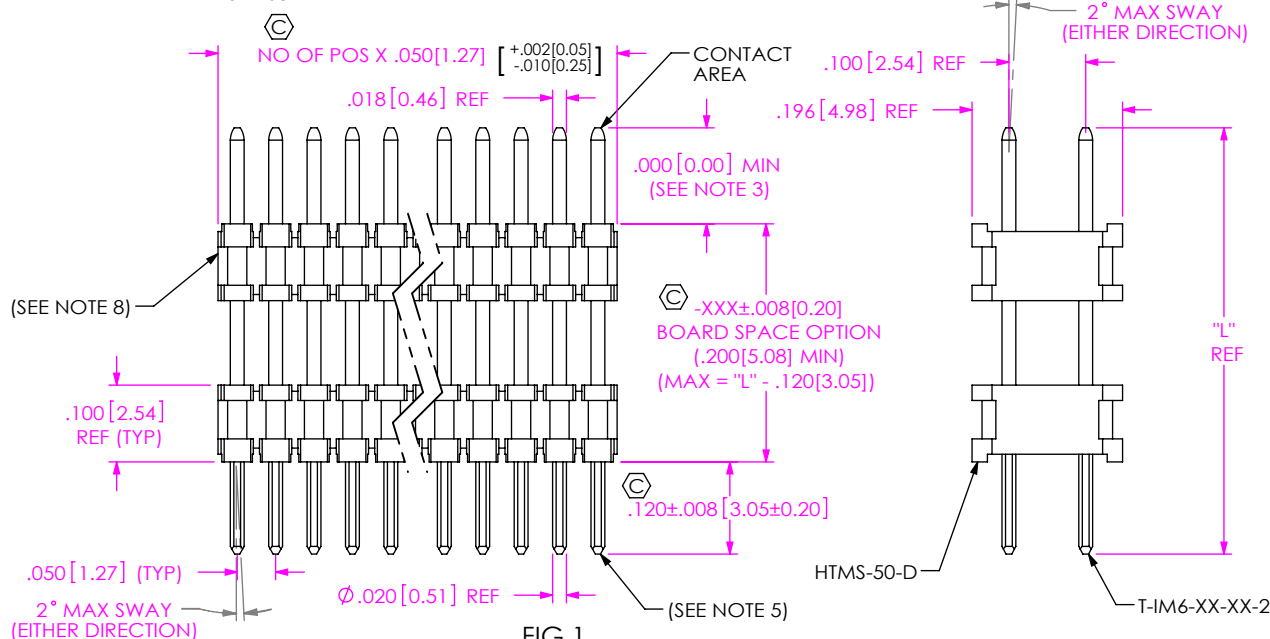
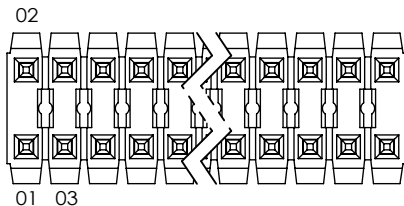

FIG 1
(DOUBLE BODY SPECIFICATION)

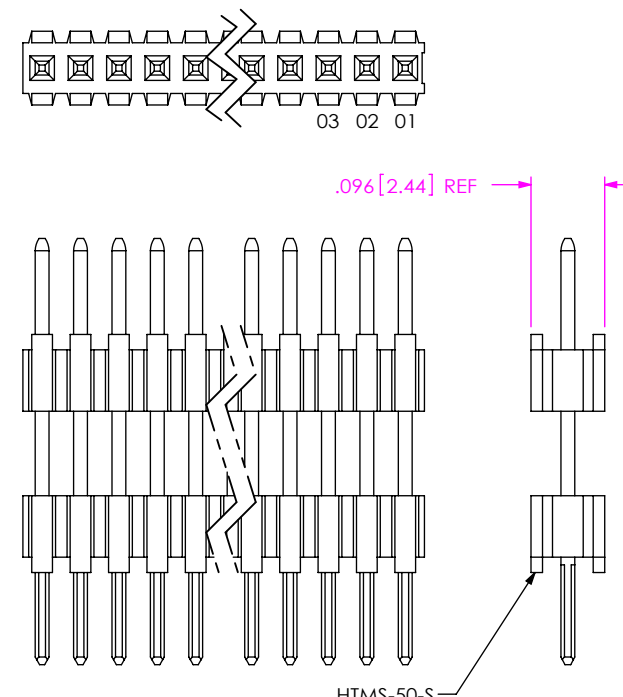

FIG 2
(SINGLE BODY SPECIFICATION)
(DIFFERENT AS SHOWN, OTHERWISE SAME AS FIG 1)

TABLE 1

LEAD STYLE	TERMINAL SPECIFICATION	"L"	"L"- .120 [3.05] BOARD SPACE MAX (REF)	PACKAGING (7 POS MIN, SEE NOTE 7)			
				SINGLE ROW		DOUBLE ROW	
				(1)	(2)	(1)	(2)
-01	T-1M6-18-XX-2	0.450 [11.43]	0.330 [8.38]	PT-1-24-01-24	(2) TP-24	PT-1-24-15-29	(2) TP-07
-51	T-1M6-02-XX-2	0.410 [10.41]	0.290 [7.37]	PT-1-24-02-48	(2) TP-03	PT-1-24-15-29	(2) TP-07
-52	T-1M6-12-XX-2	0.425 [10.80]	0.305 [7.75]	PT-1-24-02-48	(2) TP-03	PT-1-24-15-29	(2) TP-07
-53	T-1M6-04-XX-2	0.505 [12.83]	0.385 [8.78]	PT-1-24-01-46	(2) TP-24	PT-1-24-15-29	(2) TP-07
-54	T-1M6-14-XX-2	0.555 [17.10]	0.435 [11.05]	PT-1-24-02-48	(2) TP-03	PT-1-24-15-29	(2) TP-07
-55	T-1M6-03-XX-2	0.610 [15.49]	0.490 [12.45]	PT-1-24-01-46	(2) TP-24	PT-1-24-15-29	(2) TP-07
-56	T-1M6-13-XX-2	0.625 [15.88]	0.505 [12.83]	PT-1-24-01-47	(2) TP-24	PT-1-24-15-29	(2) TP-07
-57	T-1M6-19-XX-2	0.650 [16.51]	0.530 [13.46]	PT-1-24-01-30	(2) TP-03	PT-1-24-15-29	(2) TP-07
-58	T-1M6-05-XX-2	0.705 [17.91]	0.585 [14.86]	PT-1-24-01-47	(2) TP-24	PT-1-24-01-51	(2) TP-13
-59	T-1M6-15-XX-2	0.755 [19.18]	0.635 [16.13]	PT-1-24-01-47	(2) TP-24	PT-1-24-16-29	(2) TP-07
-60	T-1M6-16-XX-2	0.825 [20.96]	0.705 [17.91]	PT-1-24-01-47	(2) TP-24	PT-1-24-08-03	(2) TP-03
-61	T-1M6-28-XX-2	1.050 [26.67]	0.930 [23.62]	PT-1-24-02-04	(2) TP-12	PT-1-24-08-03	(2) TP-07

UNLESS OTHERWISE SPECIFIED, DIMENSIONS ARE IN INCHES.
TOLERANCES ARE:
DECIMALS ANGLES
.XX: ±.01 [.3] 2°
.XXX: ±.005 [.13]
.XXXX: ±.0020 [.051]

PROPRIETARY NOTE
THIS DOCUMENT CONTAINS CONFIDENTIAL AND PROPRIETARY INFORMATION AND ALL DESIGN, MANUFACTURING, REPRODUCTION, USE, PATENT RIGHTS AND SALES RIGHTS ARE EXPRESSLY RESERVED BY SAMTEC, INC. THIS DOCUMENT SHALL NOT BE DISCLOSED, IN WHOLE OR PART, TO ANY UNAUTHORIZED PERSON OR ENTITY NOR REPRODUCED, TRANSFERRED OR INCORPORATED IN ANY OTHER PROJECT IN ANY MANNER WITHOUT THE EXPRESS WRITTEN CONSENT OF SAMTEC, INC.

MATERIAL: DO NOT SCALE DRAWING
INSULATOR: LCP, UL 94 VO, COLOR: BLACK
TERMINAL: PHOS BRONZE

SHEET SCALE: 12:1

DESCRIPTION:
HI TEMP BOARD SPACING MICRO STRIPS

DWG. NO.
HDWM-XX-XX-XX-X-XXX-XXX

BY: G REIDINGER 08/03/1992 **SHEET 1 OF 1**