

CY8CKIT-062-WiFi-BT PSoC 6 WiFi-BT Pioneer Kit

CONTENTS	
PAGE	DESCRIPTION
01	Title & Table of Contents
02	Block Diagram
03	5V Buck-Boost Regulator
04	Variable Regulator, LiPo Battery Charger
05	KitProg2 Controller
06	Kitprog2 Power & Headers
07	Type-C Controller
08	Type-C Power Path
09	PSoC 6 Power Connection
10	PSoC 6 Signals
11	On-board Peripherals
12	Expansion Headers & Memory
13	USB Host & Device Interface
14	WiFi/BT Module Interface
15	Revision History

Drawing Numbers	
PCBA	121-60435-01
PCB	600-60435-01
FAB DRW	610-60435-01
ASSY DRW	620-60435-01
SCH DRW	630-60435-01

 CYPRESS <small>EMBEDDED IN TOMORROW™</small>		CYPRESS SEMICONDUCTOR 198 CHAMPION COURT SAN JOSE, CA 95134 (408) 943-2600		
CYPRESS SEMICONDUCTOR © 2017				
SCH Title : CY8CKIT-062-WiFi-BT PSoC 6 WiFi-BT Pioneer Kit				
Page Title : Title Page				
Size A4	Document Number 630-60435-01	Drawn By AARA, TAVA	Approved By RKAD	Rev 04
Date: Wednesday, January 29, 2020			Sheet 1 of 16	

CY8CKIT-062-WiFi-BT Architecture Block Diagram

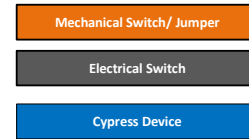
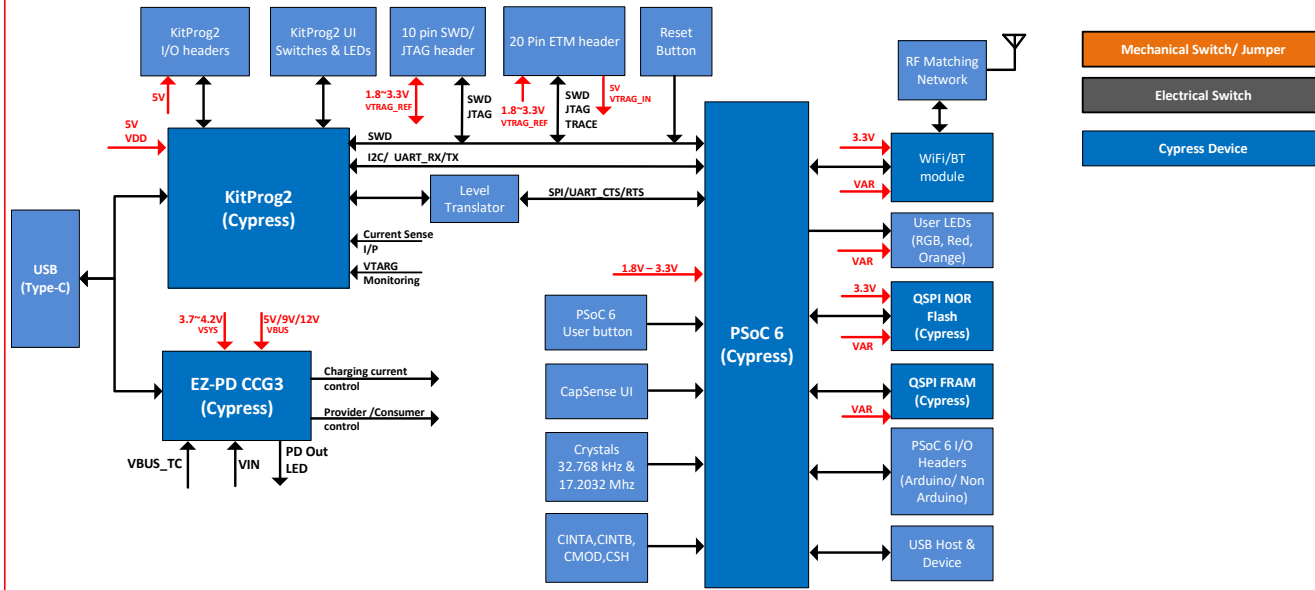

Power Supply Sub-section

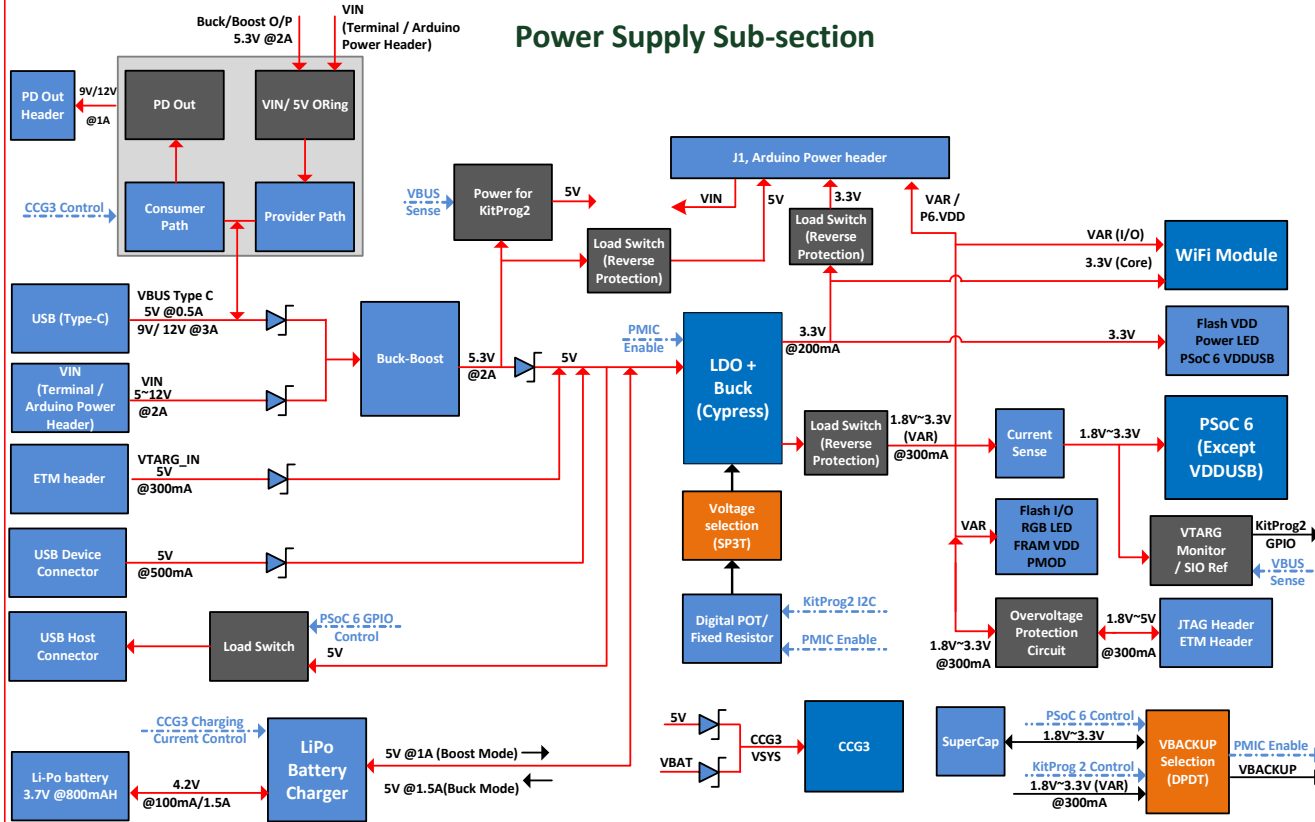

CYPRESS SEMICONDUCTOR
 198 CHAMPION COURT
 SAN JOSE, CA 95134
 (408) 943-2600

CYPRESS SEMICONDUCTOR © 2017

SCH Title : CY8CKIT-062-WiFi-BT PSoC 6 WiFi-BT Pioneer Kit

Page Title : Block Diagram

Size A4	Document Number 630-60435-01	Drawn By AARA, TAVA	Approved By RKAD	Rev 04
Date:	Wednesday, January 29, 2020		Sheet	2 of 16

KitProg2 USB Type-C Connector

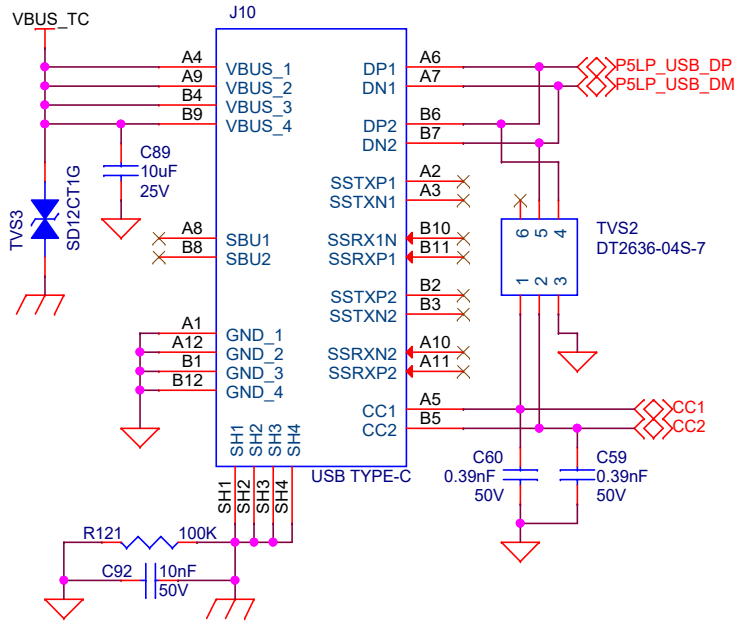

5V Buck-Boost Regulator

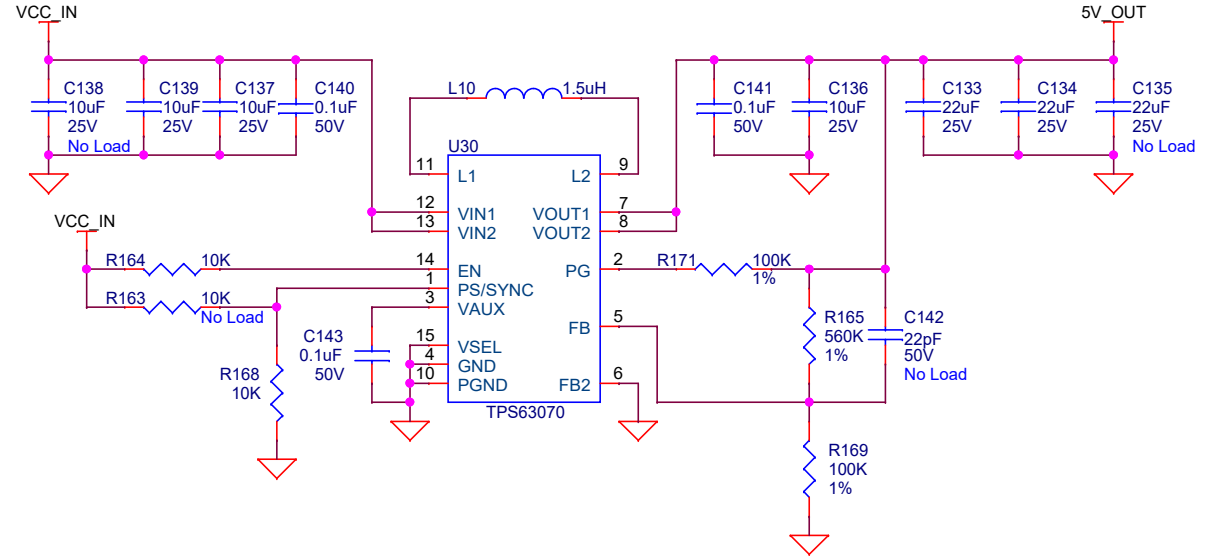

VIN Header

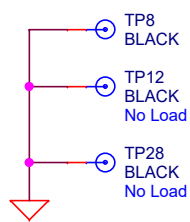
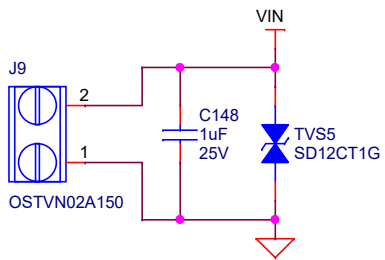

Power Supply 'OR'ing

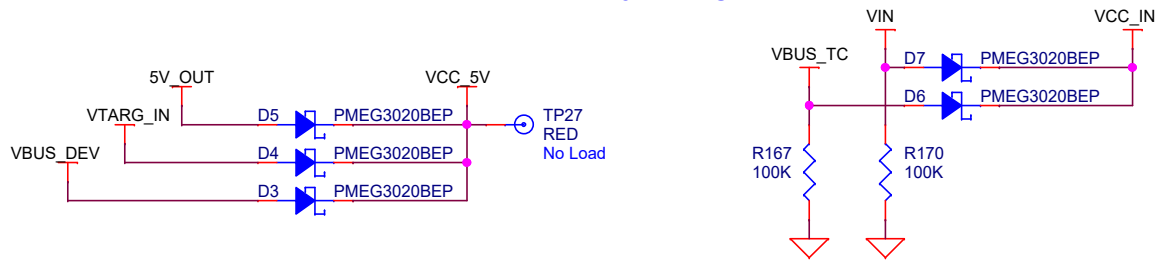

Arduino Header O/P

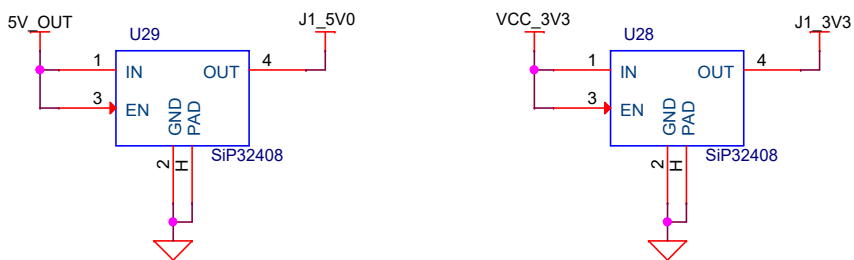

CYPRESS
 EMBEDDED IN TOMORROW™

CYPRESS SEMICONDUCTOR
 198 CHAMPION COURT
 SAN JOSE, CA 95134
 (408) 943-2600

CYPRESS SEMICONDUCTOR © 2017

SCH Title : CY8CKIT-062-WIFI-BT PSoC 6 WiFi-BT Pioneer Kit

Page Title : 5V Buck/Boost Regulator

Size A4	Document Number 630-60435-01	Drawn By AARA, TAVA	Approved By RKAD	Rev 04
Date:	Wednesday, January 29, 2020		Sheet	3 of 16

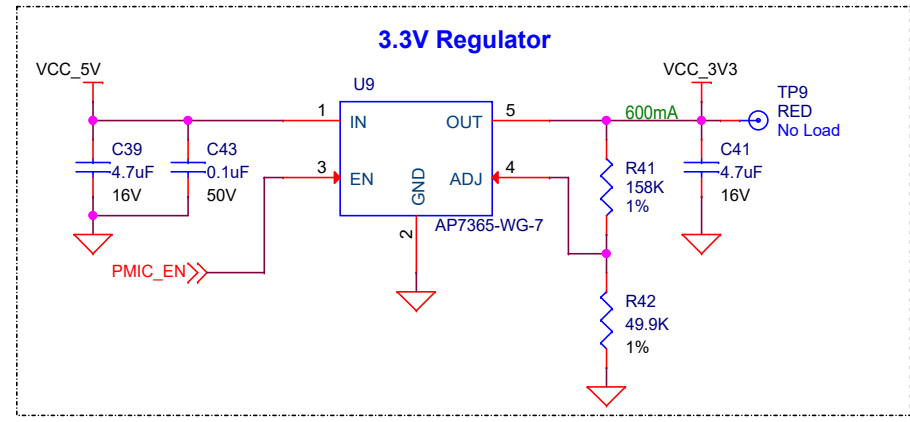
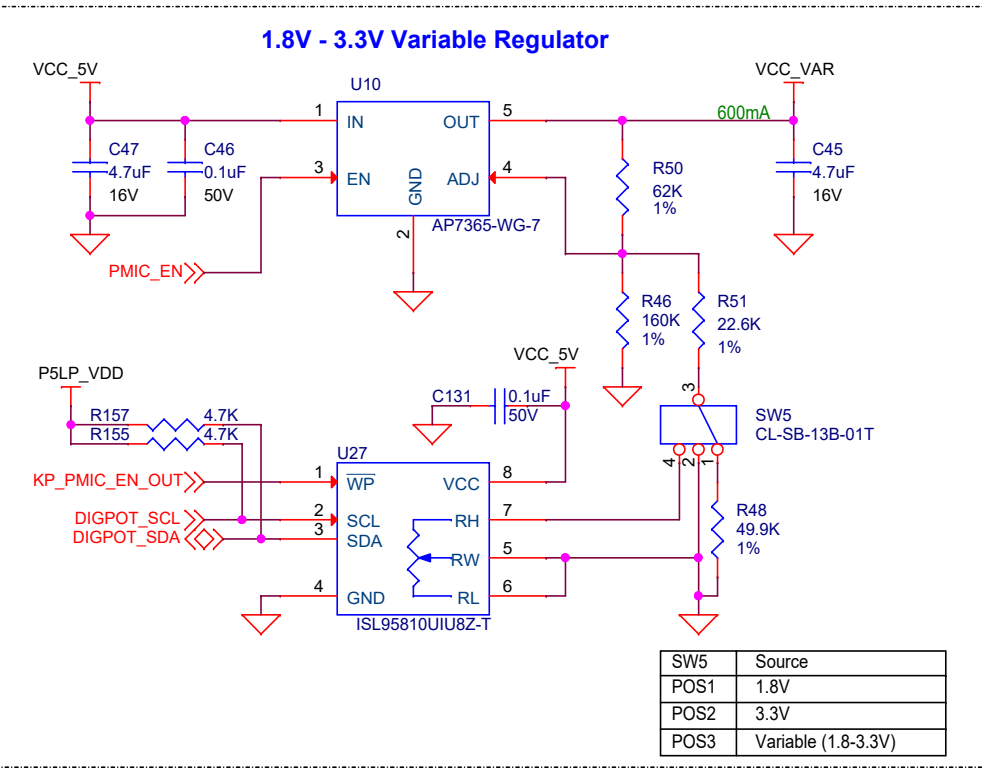
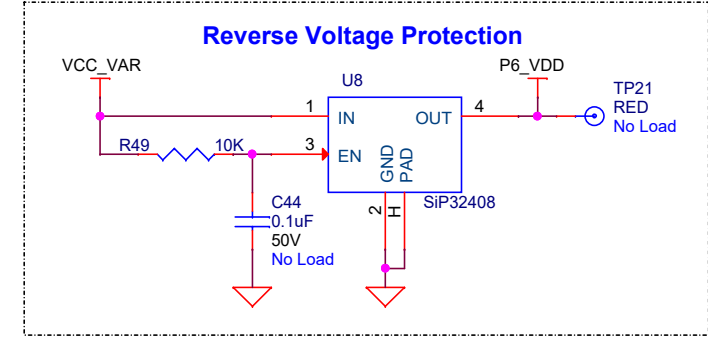
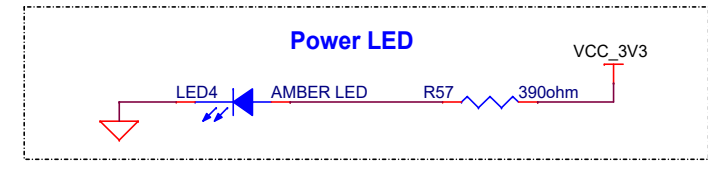
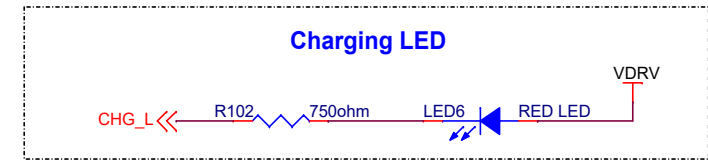
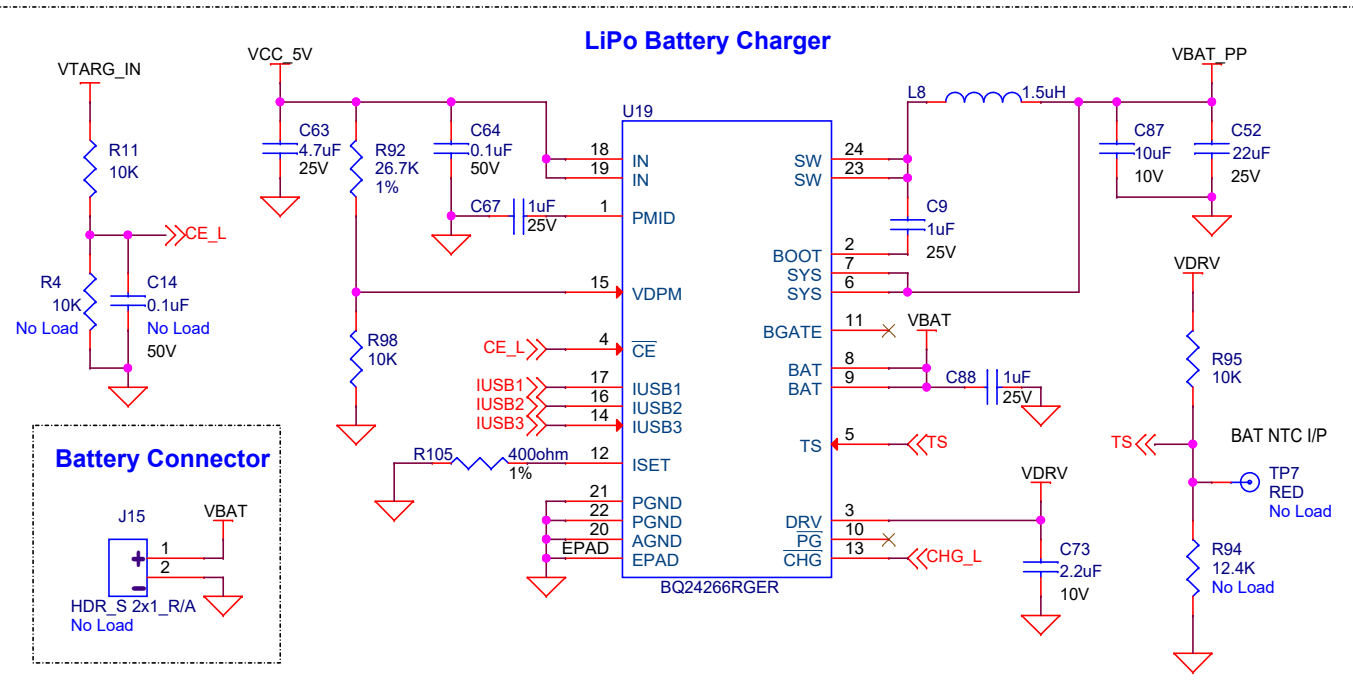

CYPRESS SEMICONDUCTOR © 2017

SCH Title : CY8CKIT-062-WIFI-BT PSoc 6 WiFi-BT Pioneer Kit

Page Title : Variable Regulator, Charger

Size A4	Document Number 630-60435-01	Drawn By AARA, TAVA	Approved By RKAD	Rev 04
Date:	Wednesday, January 29, 2020		Sheet	4 of 16

Target PSoC Program/Debug Header

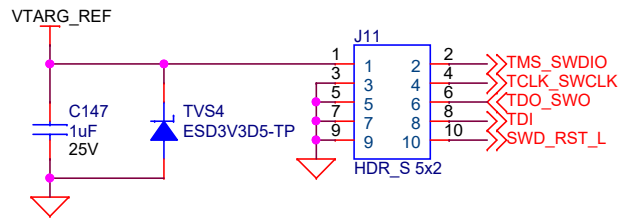

ETM Header

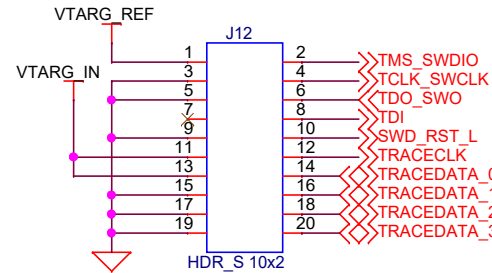

PSoC 6 SWD/JTAG Interface

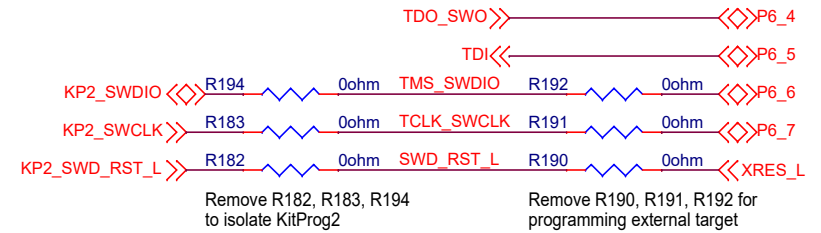

PSoC 5LP Custom Application Header

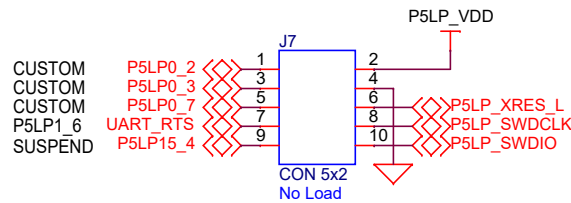

PSoC 5LP GPIO Expansion Header

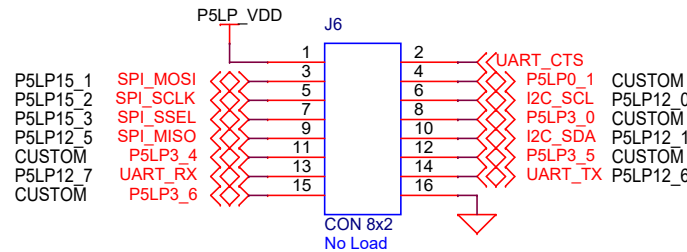

Voltage Monitoring

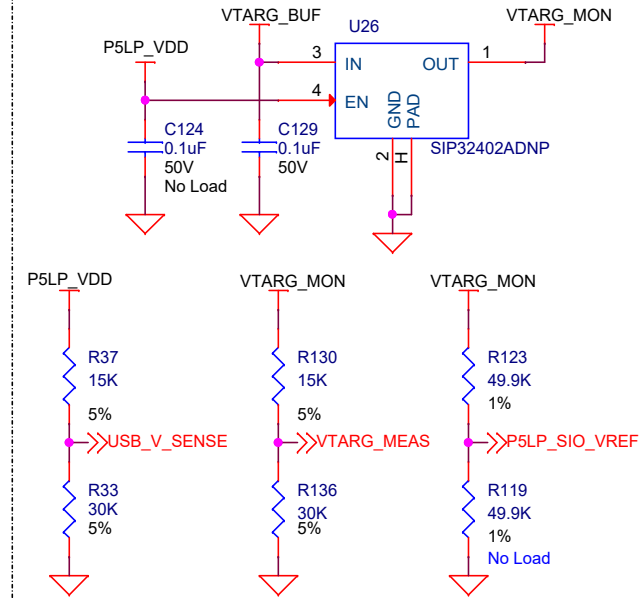

Program/Debug Overvoltage Protection

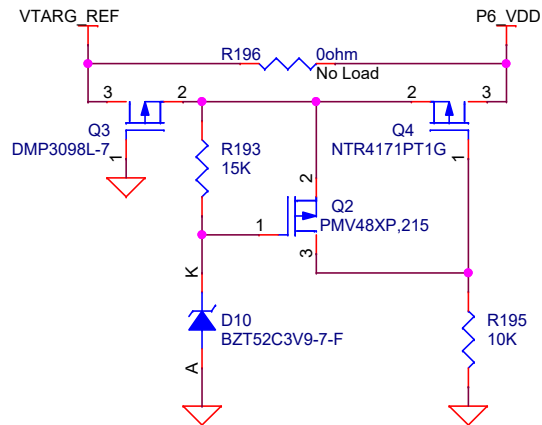

Level Translator for SPI and UART flow control

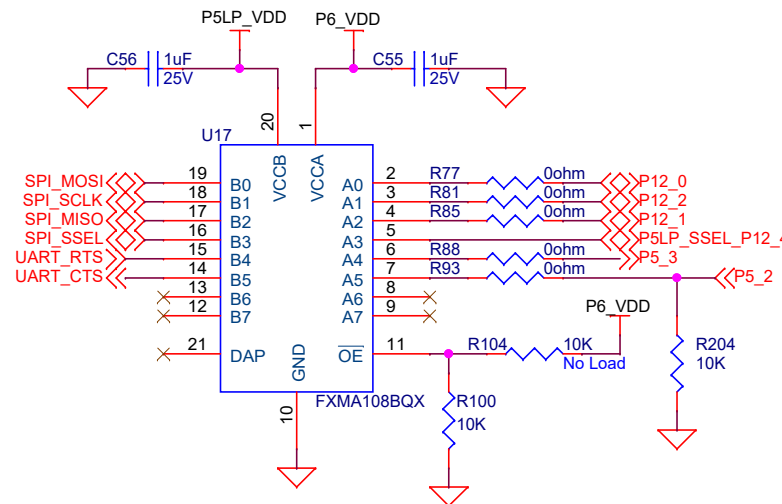

CYPRESS SEMICONDUCTOR © 2017

SCH Title : CY8CKIT-062-WIFI-BT PSoC 6 WiFi-BT Pioneer Kit

Page Title : Kitprog2 Power & Headers

Size A4	Document Number 630-60435-01	Drawn By AARA, TAVA	Approved By RKAD	Rev 04
Date:	Wednesday, January 29, 2020		Sheet	6 of 16

CCG3 Supply Selection

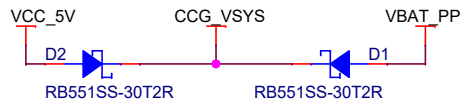

CCG3 USB Type-C Controller

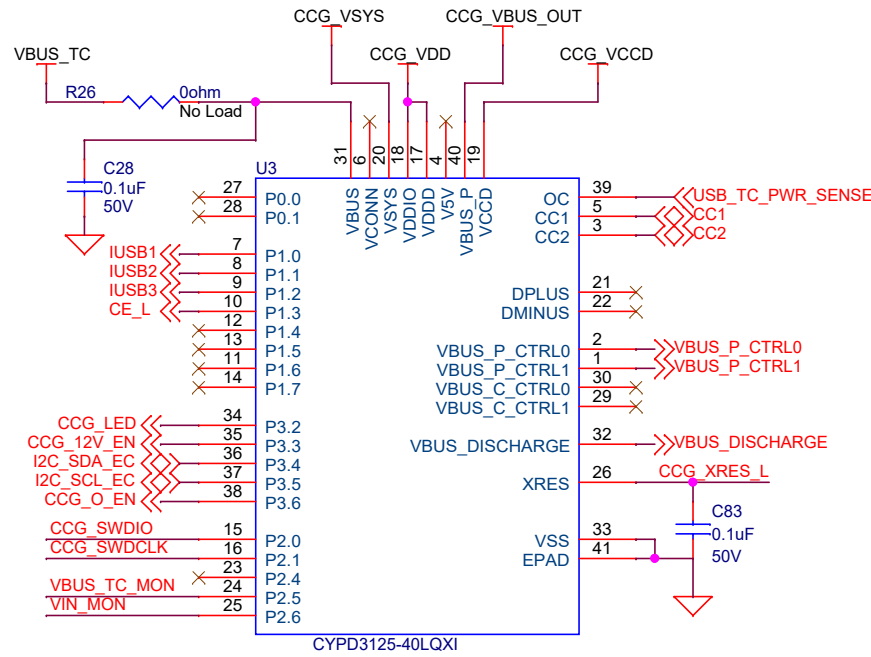

Decoupling Capacitors

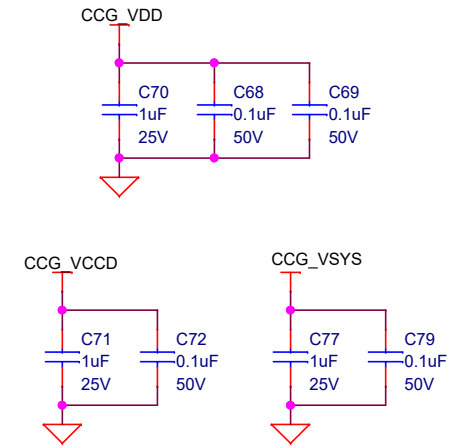

VBUS & VIN Voltage Monitoring

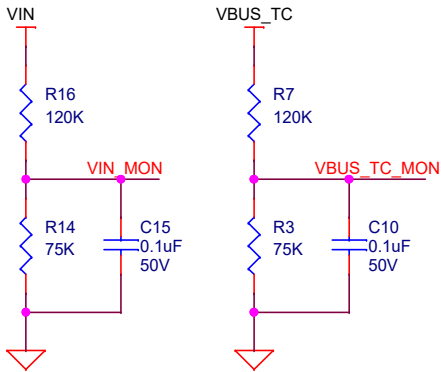

I2C Bootloader

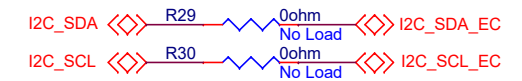

LiPo Battery Charger Pull Up

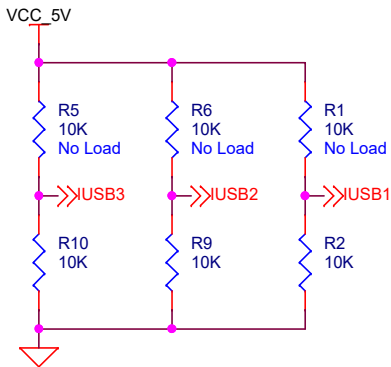

CCG3 Programming

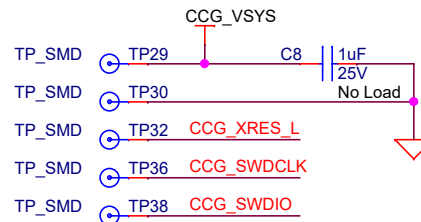

Output Indication



CYPRESS SEMICONDUCTOR © 2017

SCH Title : CY8CKIT-062-WiFi-BT PSoC 6 WiFi-BT Pioneer Kit

Page Title : Type-C Controller

Size A4	Document Number 630-60435-01	Drawn By AARA, TAVA	Approved By RKAD	Rev 04
Date:	Wednesday, January 29, 2020		Sheet	7 of 16

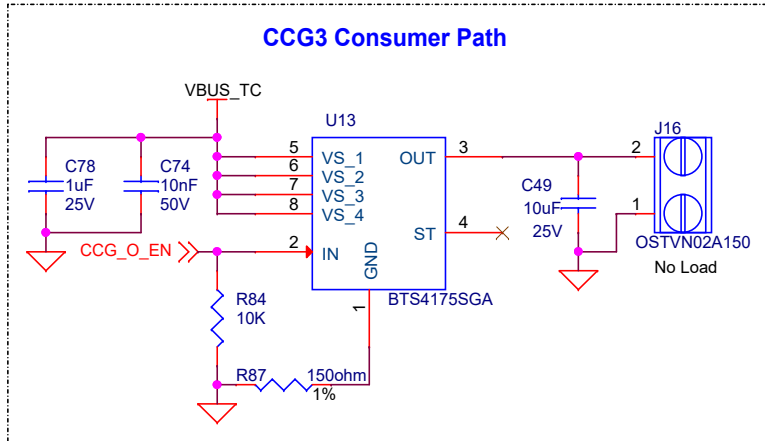
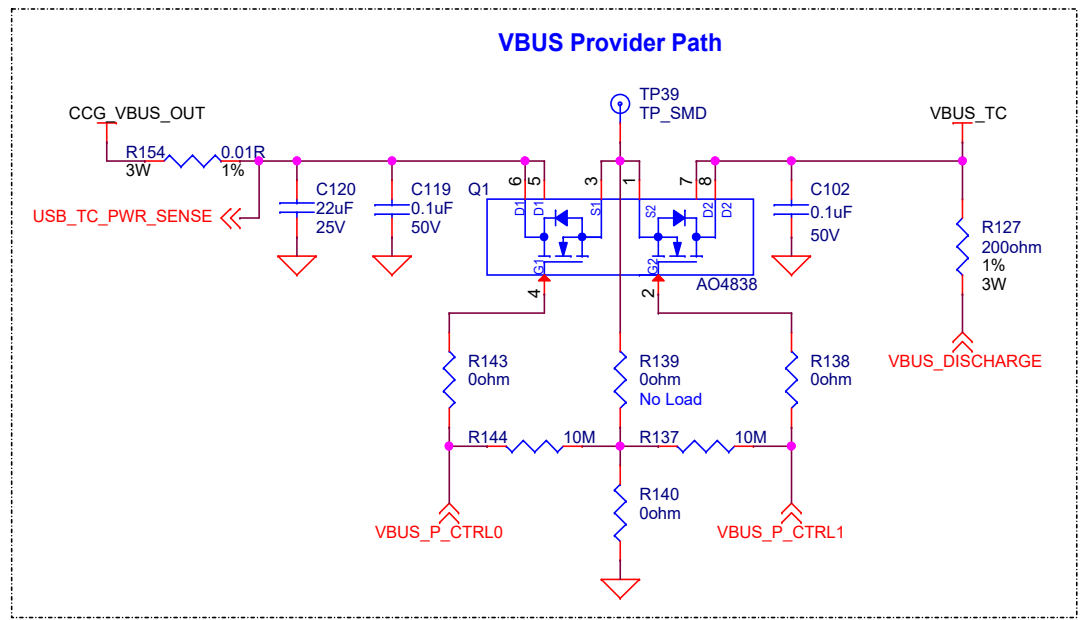
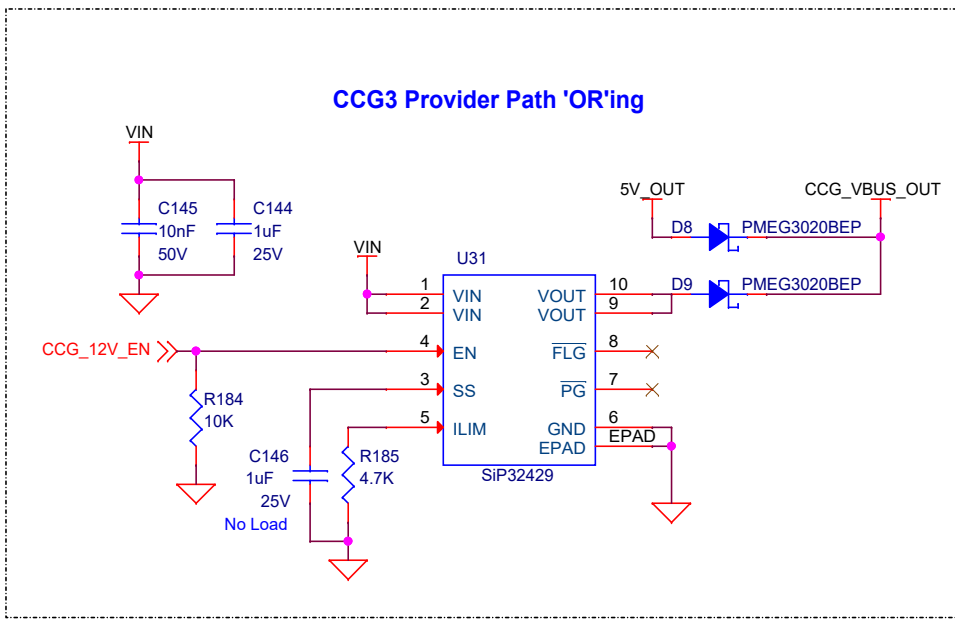

CYPRESS SEMICONDUCTOR © 2017				
SCH Title : CY8CKIT-062-WiFi-BT PSoC 6 WiFi-BT Pioneer Kit				
Page Title : Type-C Power Path				
Size A4	Document Number 630-60435-01	Drawn By AARA, TAVA	Approved By RKAD	Rev 04
Date: Wednesday, January 29, 2020		Sheet 8 of 16		

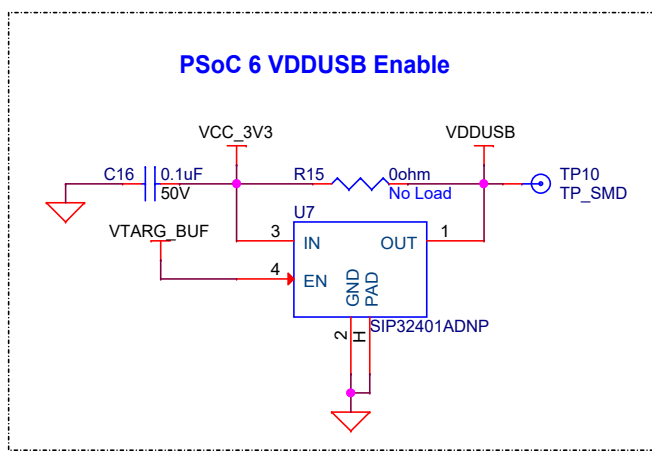
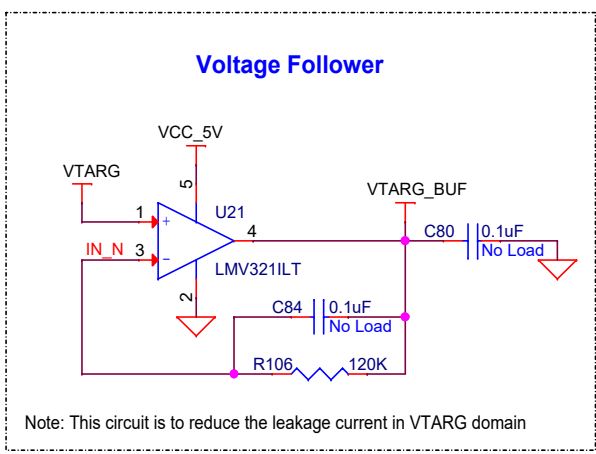
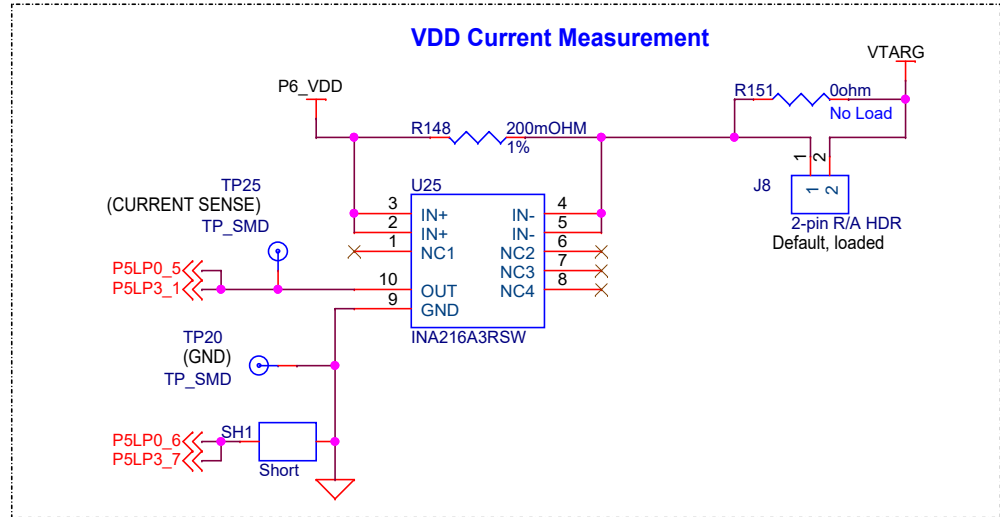
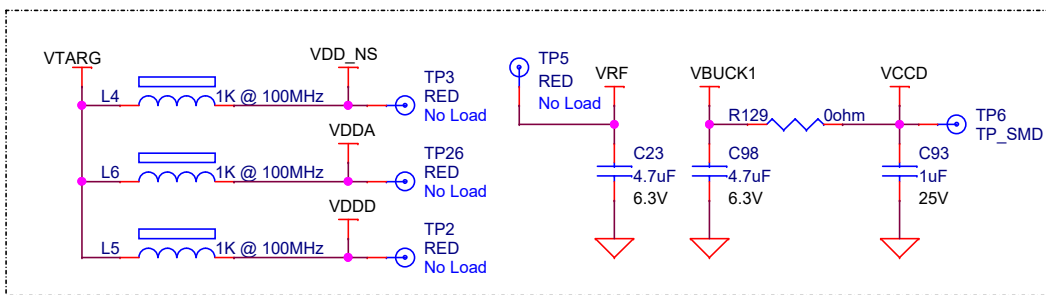
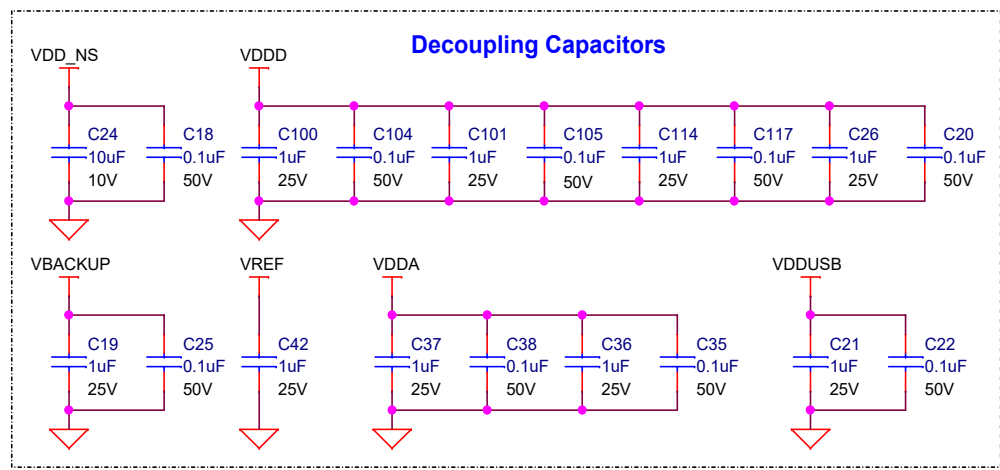
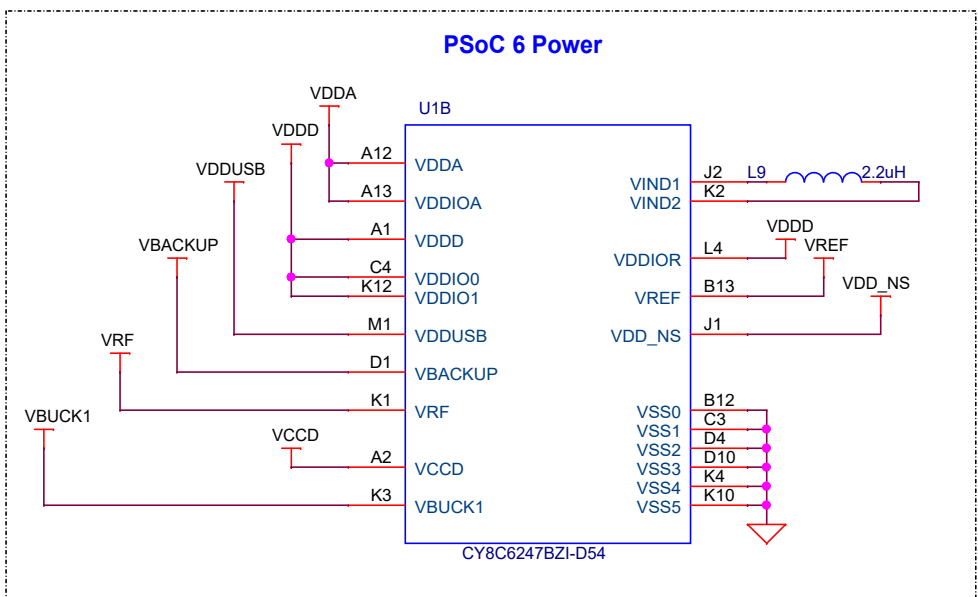

CYPRESS
EMBEDDED IN TOMORROW™

CYPRESS SEMICONDUCTOR
198 CHAMPION COURT
SAN JOSE, CA 95134
(408) 943-2600

CYPRESS SEMICONDUCTOR © 2017

SCH Title : CY8CKIT-062-WiFi-BT PSoc 6 WiFi-BT Pioneer Kit

Page Title : PSoc 6 Power

Size A4	Document Number 630-60435-01	Drawn By AARA, TAVA	Approved By RKAD	Rev 04
Date: Wednesday, January 29, 2020	Sheet 9 of 16			

PSoC 6 Signals

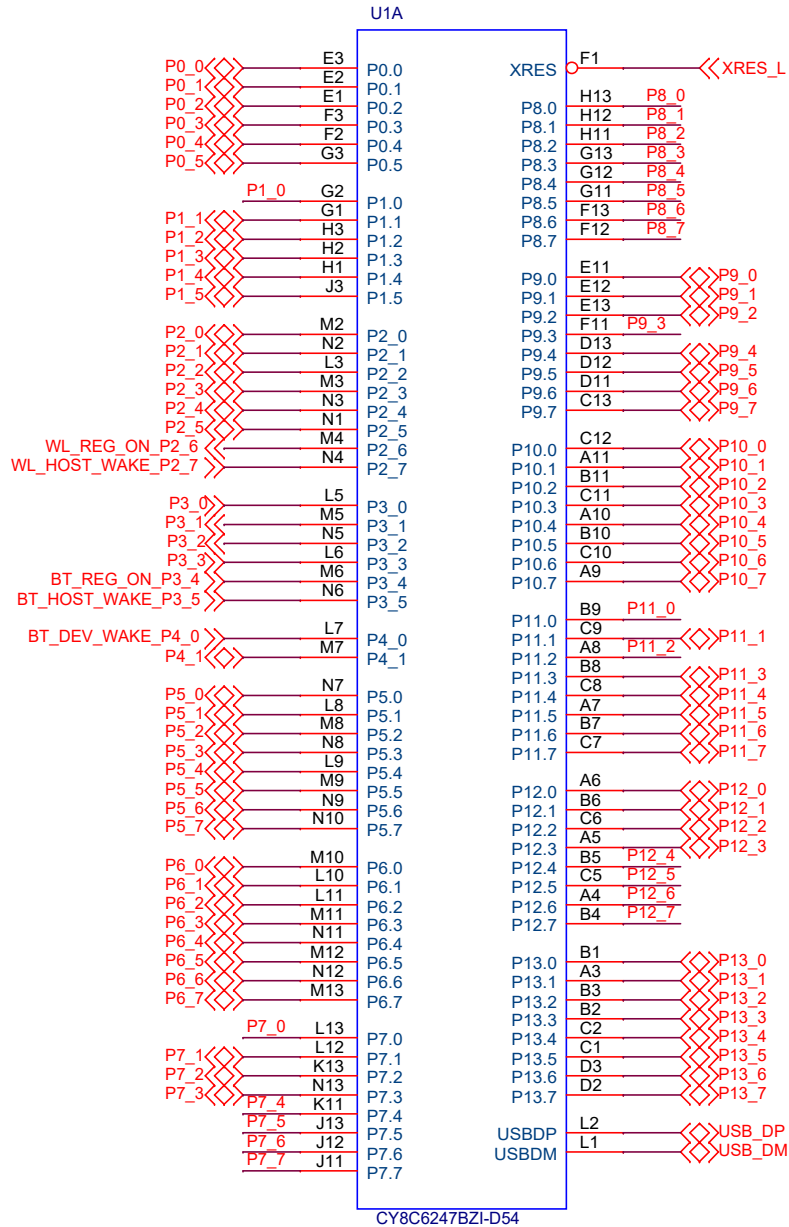

Additional Multiplexed Pins

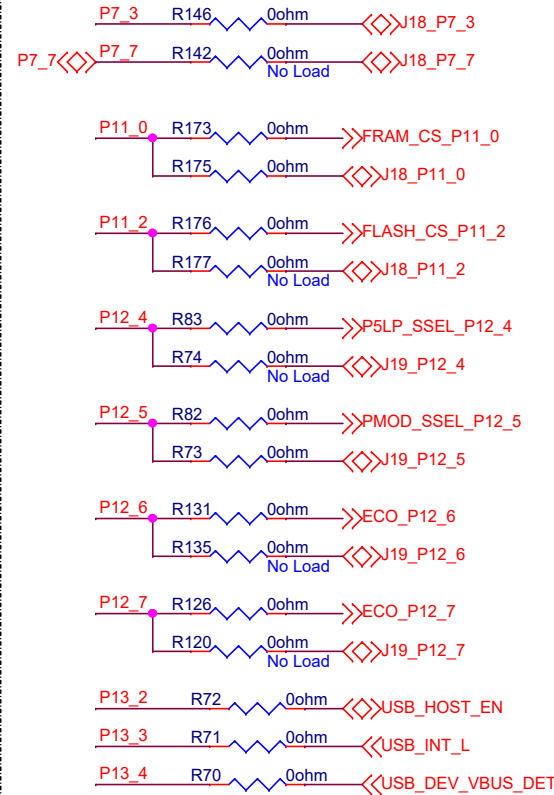

TRACE Multiplexed Pins

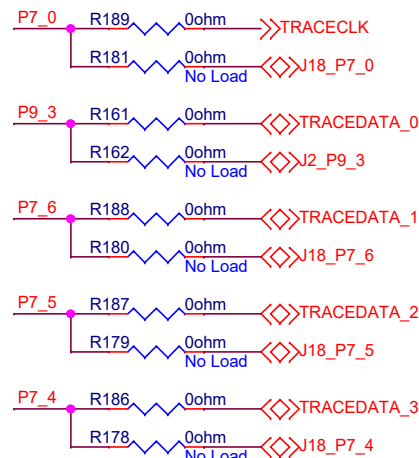

CapSense Multiplexed Pins

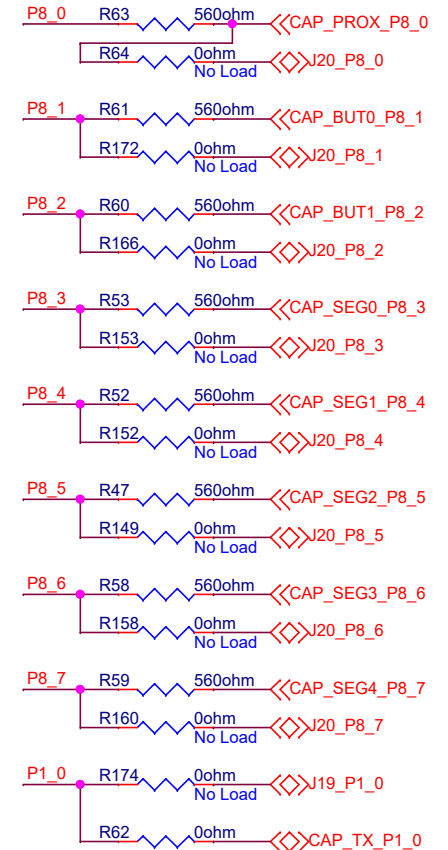

Note: Option for WLAN to wake PSoC 6 from Hibernate





CYPRESS SEMICONDUCTOR © 2017

SCH Title : CY8CKIT-062-WIFI-BT PSoC 6 WiFi-BT Pioneer Kit

Page Title : PSoC 6 Signals

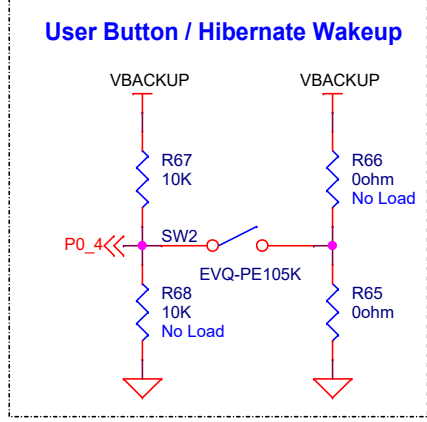
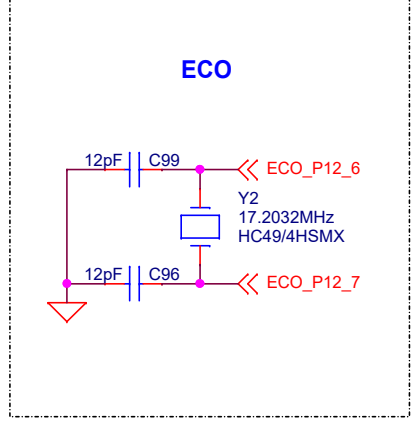
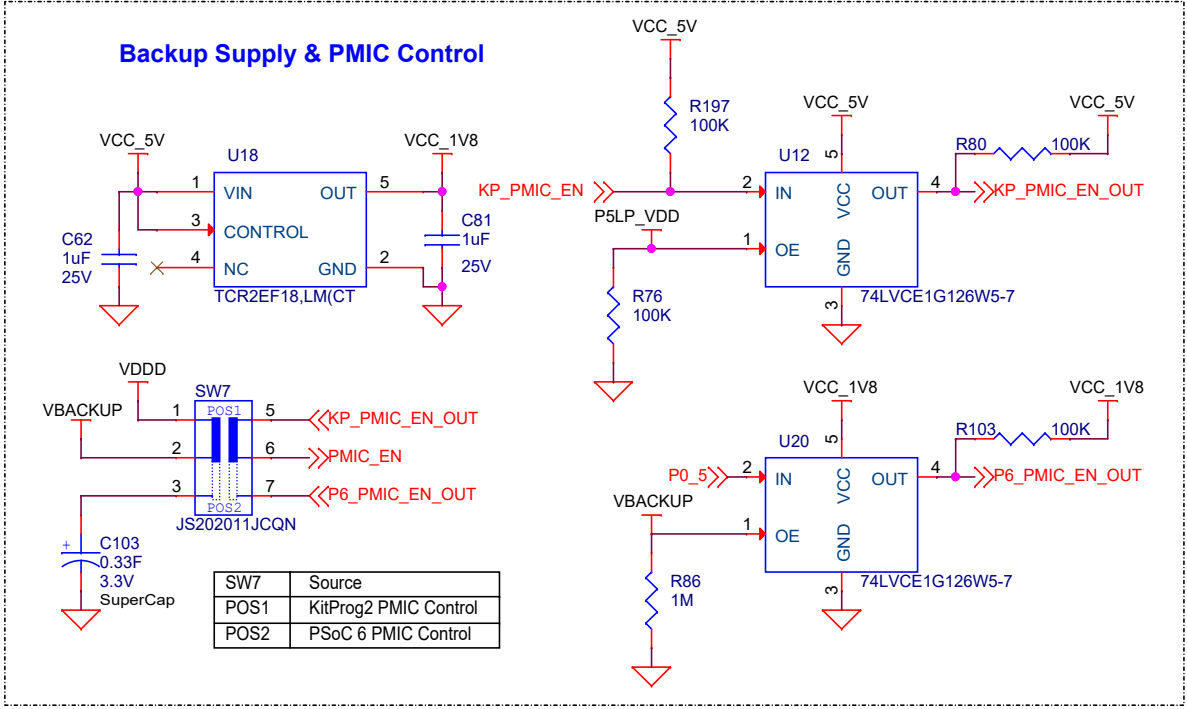
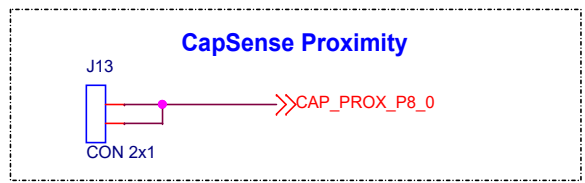
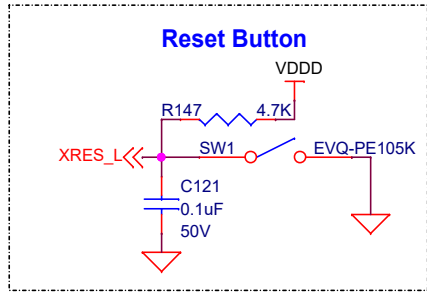
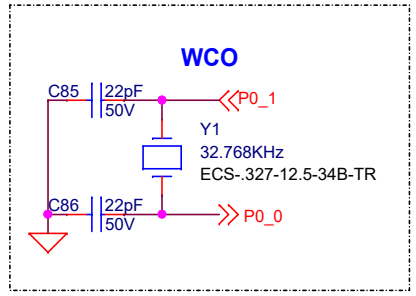
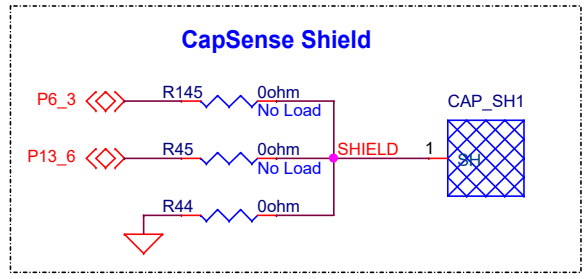
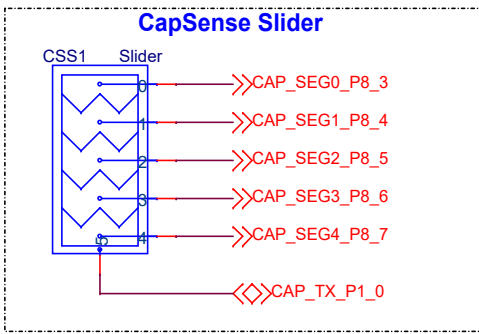
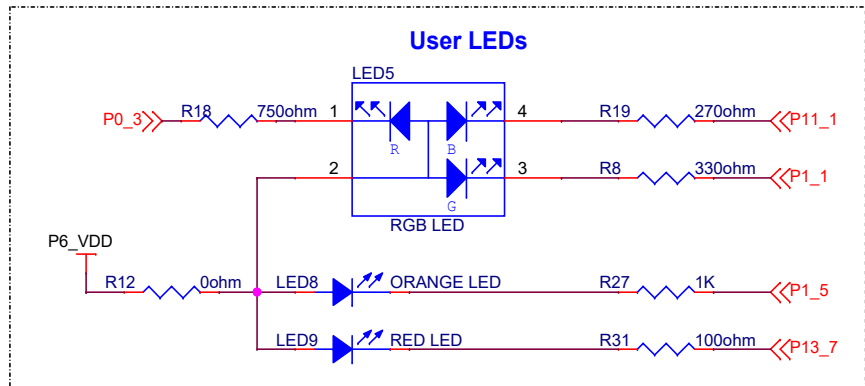
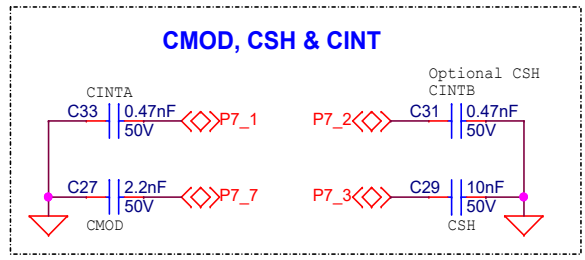
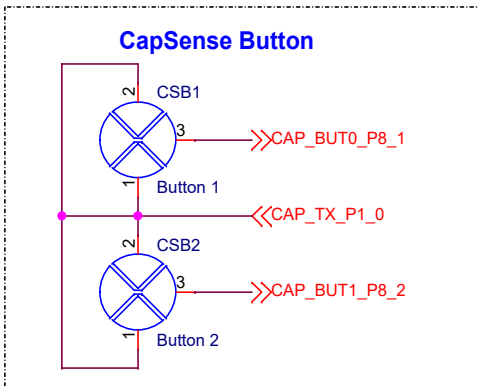
Size A4	Document Number 630-60435-01	Drawn By AARA, TAVA	Approved By RKAD	Rev 04
Date:	Wednesday, January 29, 2020		Sheet	10 of 16





CYPRESS SEMICONDUCTOR
198 CHAMPION COURT
SAN JOSE, CA 95134
(408) 943-2600

CYPRESS SEMICONDUCTOR © 2017

SCH Title : CY8CKIT-062-WIFI-BT PSoc 6 WiFi-BT Pioneer Kit

Page Title : On-board peripherals

Size A4	Document Number 630-60435-01	Drawn By AARA, TAVA	Approved By RKAD	Rev 04
Date: Wednesday, January 29, 2020		Sheet 11 of 16		

Arduino & Extended Headers

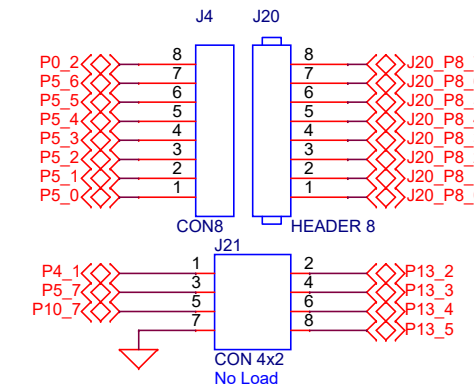
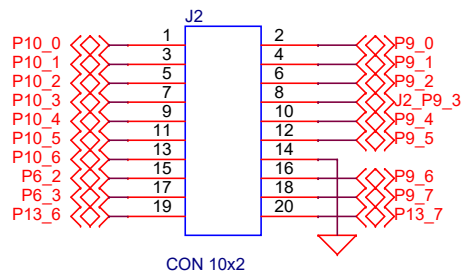
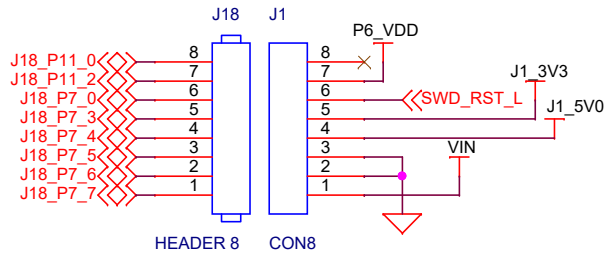

PMOD Header

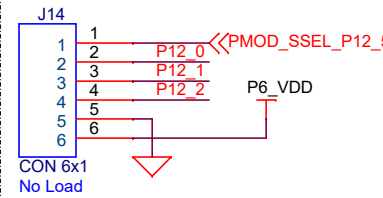

ICSP Header

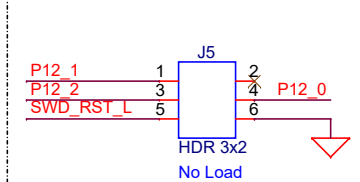

FRAM

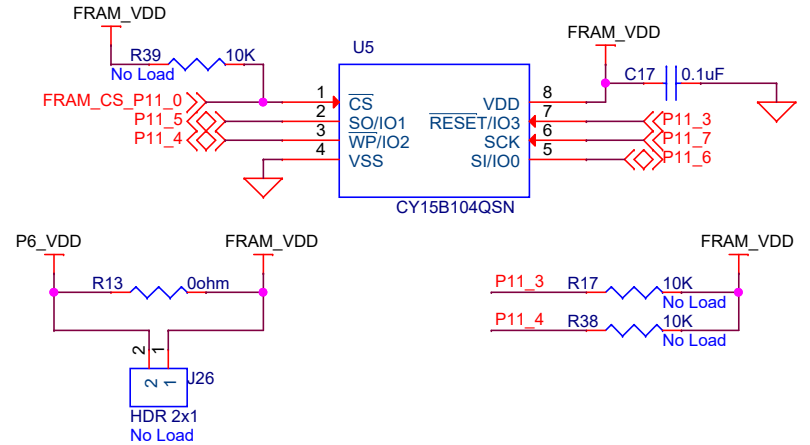

QSPI Flash (SMIF)

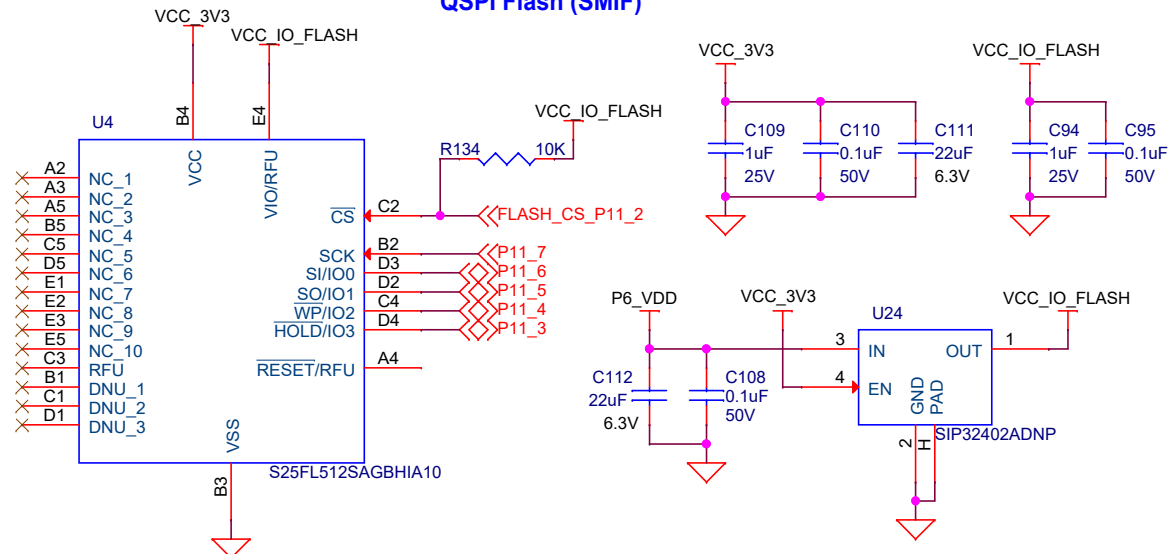

CYPRESS
EMBEDDED IN TOMORROW™
198 CHAMPION COURT
SAN JOSE, CA 95134
(408) 943-2600

CYPRESS SEMICONDUCTOR © 2017

SCH Title : CY8CKIT-062-WIFI-BT PSoC 6 WiFi-BT Pioneer Kit

Page Title : Expansion headers & Memory

Size A4	Document Number 630-60435-01	Drawn By AARA, TAVA	Approved By RKAD	Rev 04
Date:	Wednesday, January 29, 2020		Sheet	12 of 16

USB Multiplexer

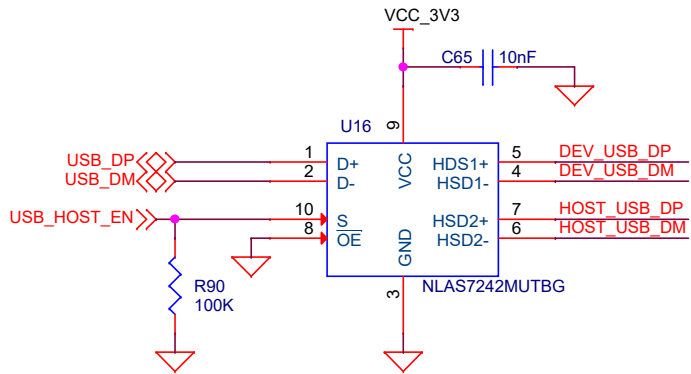

USB Type-A Receptacle (Host)

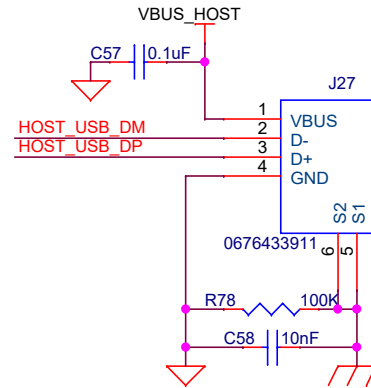

USB Type-C Connector (Device)

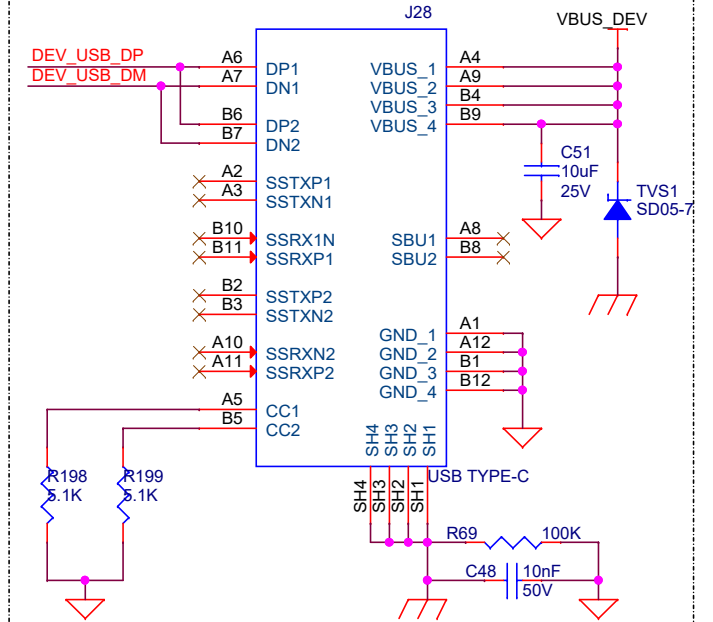

USB Device Port VBUS Detect

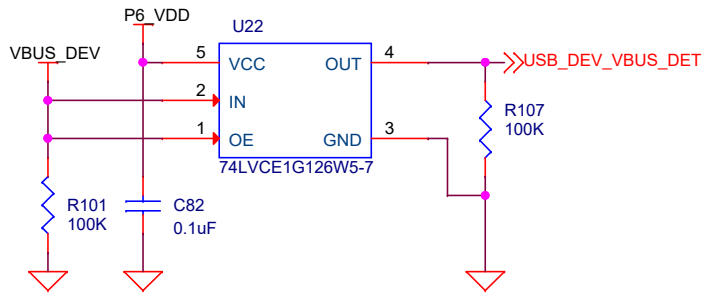

USB Host VBUS Enable

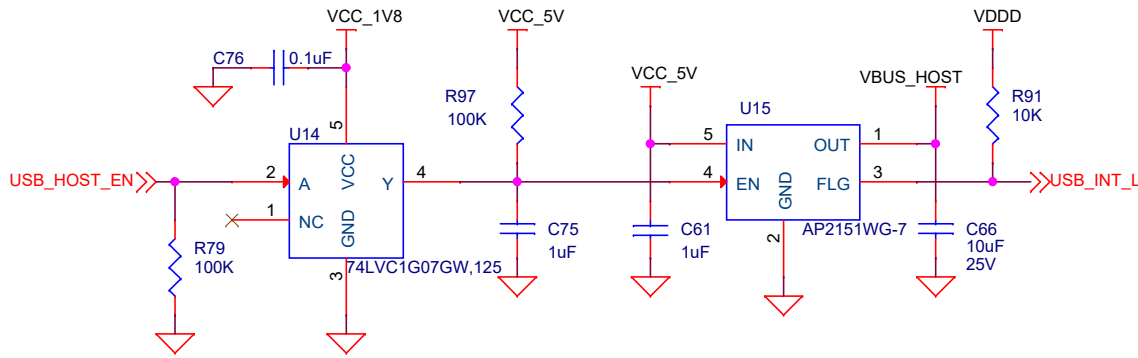

CYPRESS SEMICONDUCTOR © 2017				
SCH Title : CY8CKIT-062-WIFI-BT PSoC 6 WiFi-BT Pioneer Kit				
Page Title : USB Host & Device Interface				
Size A4	Document Number 630-60435-01	Drawn By AARA, TAVA	Approved By RKAD	Rev 04
Date:	Wednesday, January 29, 2020		Sheet	13 of 16

WiFi Interface with PSoC 6

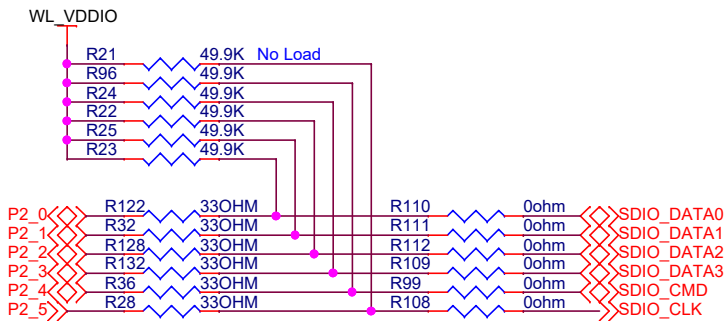

Optional JTAG Interface

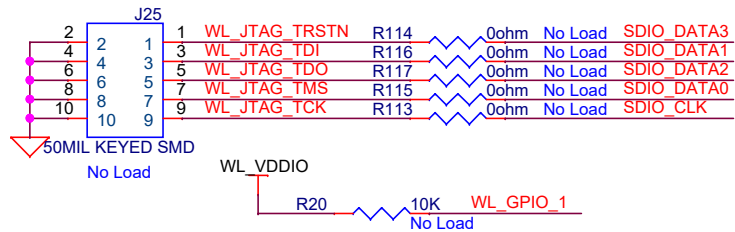

Supply for WiFi Module

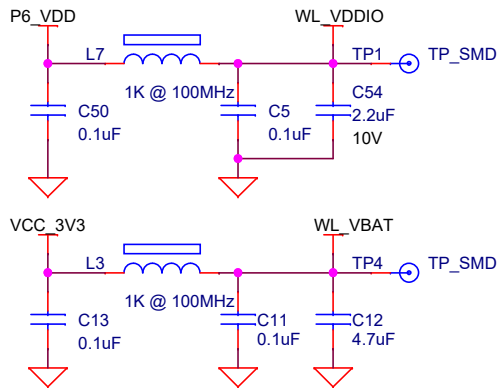

Testpoints

WL_GPIO_1	TP16	No Load
WL_GPIO_2	TP11	No Load
WL_GPIO_4	TP19	No Load
WL_REG_ON_P2_6	TP33	TP_SMD
WL_HOST_WAKE_P2_7	TP34	TP_SMD
BT_REG_ON_P3_4	TP37	TP_SMD
BT_HOST_WAKE_P3_5	TP31	TP_SMD
BT_DEV_WAKE_P4_0	TP35	TP_SMD
BT_GPIO_3	TP22	TP_SMD
BT_GPIO_4	TP23	TP_SMD
BT_GPIO_5	TP17	TP_SMD
BT_I2S_DO	TP18	TP_SMD
BT_PCM_SYNC	TP24	TP_SMD
BT_PCM_IN	TP13	TP_SMD
BT_PCM_OUT	TP14	TP_SMD
BT_PCM_CLK	TP15	TP_SMD
BT_UART_RXD	TP40	TP_SMD
BT_UART_TXD	TP41	TP_SMD
BT_UART_CTS	TP42	TP_SMD
BT_UART_RTS	TP43	TP_SMD

WiFi / BT Module

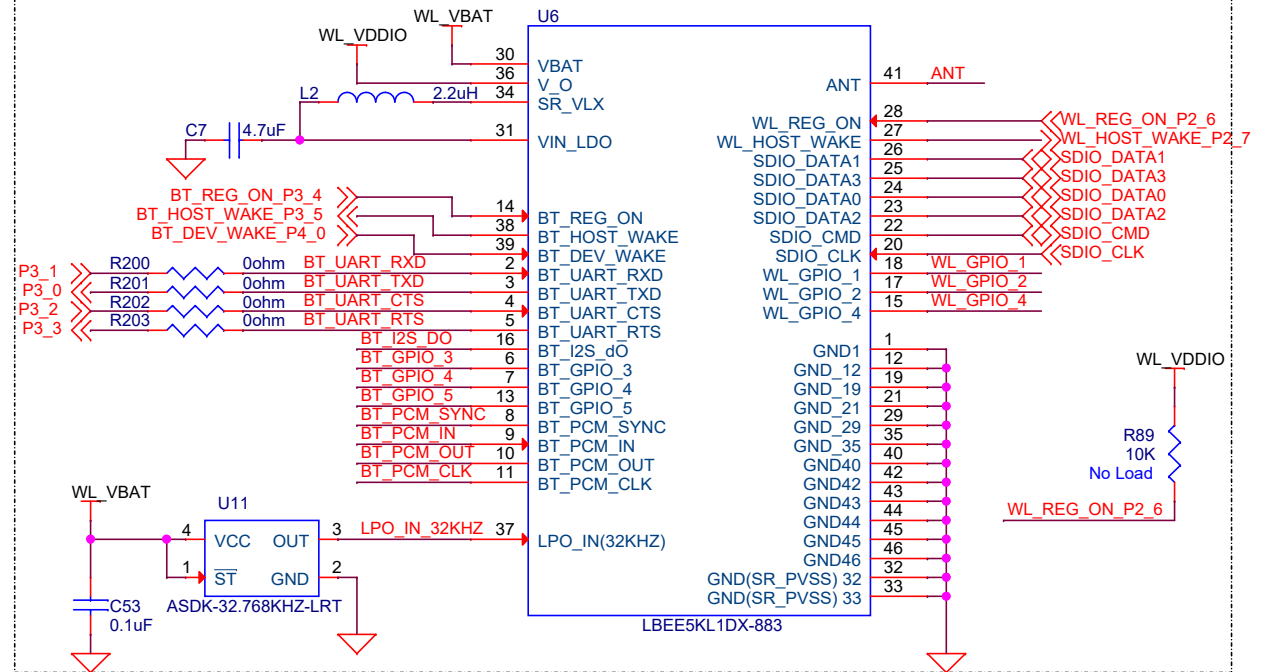

Antenna with Matching Network

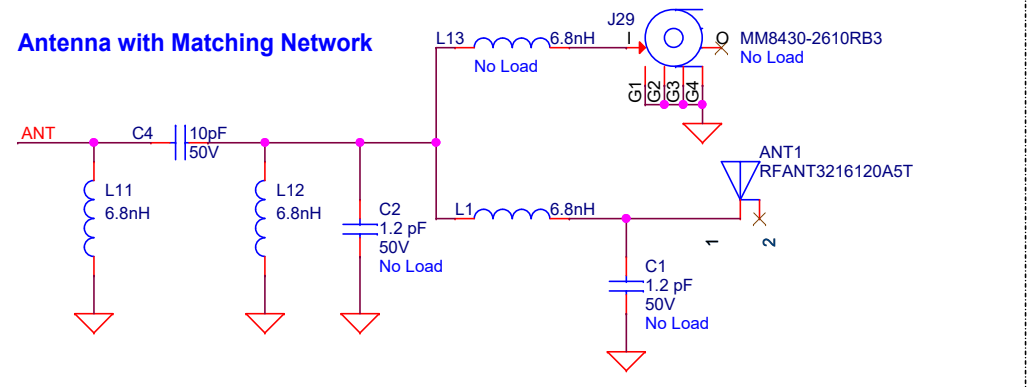

CYPRESS SEMICONDUCTOR © 2017

SCH Title : CY8CKIT-062-WIFI-BT PSoC 6 WiFi-BT Pioneer Kit

Page Title : WiFi Module Interface

Size A4	Document Number 630-60435-01	Drawn By AARA, TAVA	Approved By RKAD	Rev 04
Date:	Wednesday, January 29, 2020		Sheet	14 of 16

Accessories

Cylindrical Bumper

SJ61A4

SJ61A4

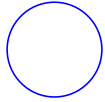
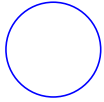

SJ61A4

SJ61A4

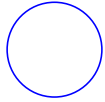
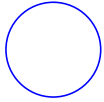

Acrylic Overlay

Acrylic Overlay

Color: Clear, Transparent
Finish: Matt

40 x 34 x 1mm

Jumper Shunt

SPC02SYAN

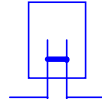

USB Type-C Connector Brackets

298 SV001

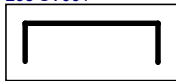

298 SV001

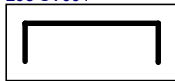

PCBA label

LBL PCA Label



LBL QR Code



CYPRESS
EMBEDDED IN TOMORROW™

CYPRESS SEMICONDUCTOR
198 CHAMPION COURT
SAN JOSE, CA 95134
(408) 943-2600

CYPRESS SEMICONDUCTOR © 2017

SCH Title : CY8CKIT-062-WiFi-BT PSoC 6 WiFi-BT Pioneer Kit

Page Title : Accessories

Size A4	Document Number 630-60435-01	Drawn By AARA, TAVA	Approved By RKAD	Rev 04
Date:	Wednesday, January 29, 2020		Sheet	15 of 16

REVISION HISTORY

REV	DESCRIPTION OF CHANGE	DATE
01	Internal Release	2017/03/13
02	Internal Release	2017/09/01
03	Initial Release	2017/10/20
04	Changed WCO load capacitors C85 and C86	2020/01/29



CYPRESS
EMBEDDED IN TOMORROW™

CYPRESS SEMICONDUCTOR
198 CHAMPION COURT
SAN JOSE, CA 95134
(408) 943-2600

CYPRESS SEMICONDUCTOR © 2017

SCH Title : CY8CKIT-062-WiFi-BT PSoC 6 WiFi-BT Pioneer Kit

Page Title : Internal Revision History

Size A4	Document Number 630-60435-01	Drawn By AARA, TAVA	Approved By RKAD	Rev 04
Date:	Wednesday, January 29, 2020		Sheet	16 of 16