

Demonstration Board EPC9145 Quick Start Guide

*1 kW, 3-phase BLDC Motor Drive Inverter using the
EPC2206 eGaN[®] FET*

Revision 1.2

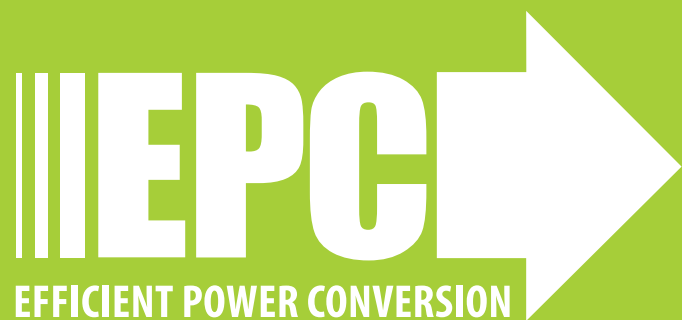

DESCRIPTION

The EPC9145 demonstration board is a 3-phase BLDC motor drive inverter board featuring the EPC2206 eGaN FET 2.2 mΩ maximum $R_{DS(on)}$, 80 V maximum device voltage, it can deliver up to 28 A_{pk} (20 A_{RMS}) maximum output current. The board can also be configured for multi-phase DC-DC conversion and the EPC2206 supports PWM switching frequencies up to 250kHz. The EPC9145 contains all the necessary critical functions circuits to support a complete motor drive inverter including gate drivers, regulated auxiliary power rails for housekeeping supplies, voltage, and temperature sense, accurate current sense, and protection functions. The various functional blocks are shown in figure 1. The EPC9145 mates with an assortment of compatible controllers, supported by various manufacturers leveraging existing resources for quick development purposes, that can quickly be configured as a motor drive inverter or DC-DC converter.

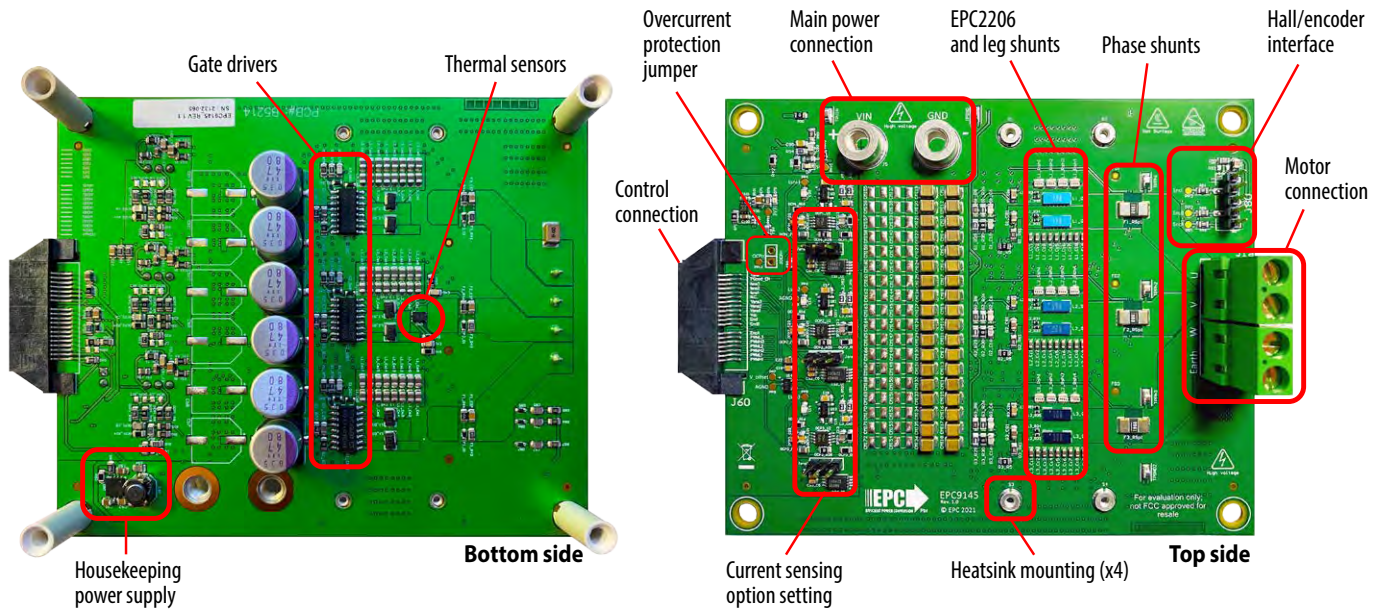

Figure 1: Photo overview of the EPC9145 board highlighting the main sections

A functional block diagram of the EPC9145 demonstration board is shown in figure 2 that details the phase current sense, phase and DC voltage sense, the half-bridge power stages, L-C filter, housekeeping power supply and controller interface connection.

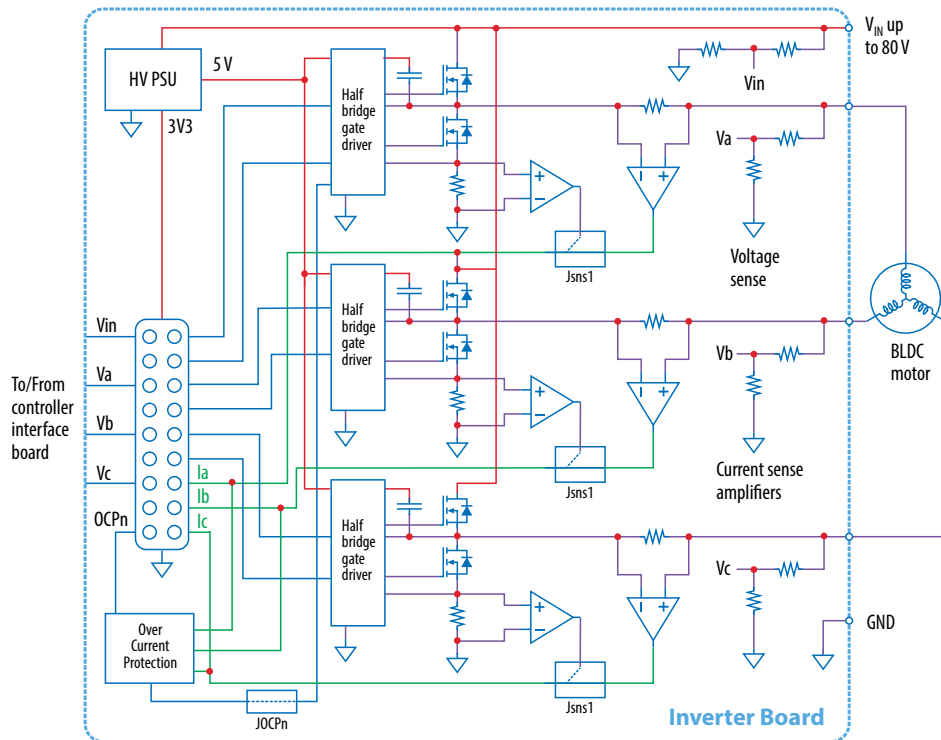
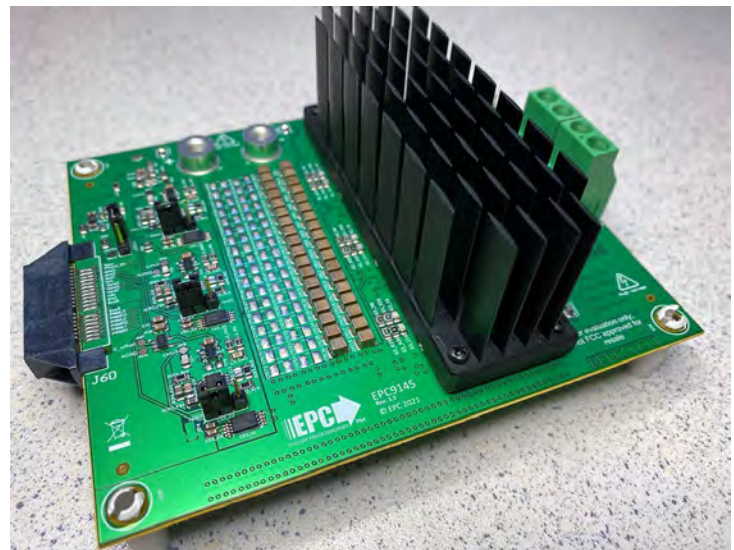

Figure 2. Block diagram of EPC9145 board in BLDC drive example application

MAIN FEATURES

- 3-phase inverter based on EPC2206 eGaN FET with wide input voltage ranging from 12 V_{IN} to 60 V
- Dimensions: L x W = 130 mm x 100 mm (including connector)
- Low distortion switching that keep motor audio emission low and reduces torque ripple
- dv/dt optimized for motor drives less than 10 V/ns with option to increase dv/dt for DC–DC applications
- All current sense with high accuracy and bandwidth (option to choose between in- line and leg shunt current sensors)
- All phases voltage sense
- Voltage sense for the DC supply to the drive
- Housekeeping power for the various circuits and external controller derived from the main power supply to the EPC9145
- Temperature monitoring circuit
- Protection features including: over-current and input supply under voltage lockout
- Shaft encoder/Hall sensors interface connector for motor drive application with two voltage levels selection options
- The board can also be configured to operate as a synchronous buck DC–DC converter.



EPC9145 Demonstration board with heatsink attached

RECOMMENDED OPERATING CONDITIONS

Table 1: Electrical Specifications (T_A = 25°C) EPC9145

Symbol	Parameter	Conditions	Min	Nom	Max	Units
V _{IN}	Input supply voltage		14	48	60	V
I _{Phase}	Phase current ⁽¹⁾			20	25	A _{RMS}
f _{sw}	Switching frequency		20	100	250 ⁽⁴⁾	kHz
V _{IN_uvlo}	Input undervoltage lockout voltage			14		V
V _{IN_uvlo_hys}	Input undervoltage lockout voltage hysteresis			1.64		
V _{IH}	PWM high-level logic threshold	PWM rising edge	2.4			
V _{IL}	PWM low-level logic threshold	PWM falling edge			0.8	V
V _{IHyst}		V _{IH} Rising – V _{IL} Falling		0.5		
R _{in}	PWM input pulldown resistance			150		kΩ
PW _{min}	Minimum input pulse -width	50% level to 50% level – based on gate driver specs		120		ns
t _{Prop_delay}	PWM input to Switch-node transition delay	High-side/Low-side on/off		50		
V _{Isns_range}	Phase current sense voltage dynamic range	–I _{max} to I _{max}	0		3.3	V
I _{Isns_range}	Phase current sense dynamic range	Shunt = 1.0 mΩ, current sense amplifier gain = 20	-82.5		82.5	A
I _{ovc} ⁽²⁾	Positive over-current threshold	Over-current circuits detects both positive negative OVC		50		
V _{Isns_offset}	Amplified current sense signal offset voltage	Shunt = 1.0 mΩ, current sense amplifier gain = 20, I _{phase} = 0 A		1.65		V
G _{I_{sns}}	Amplified current sense gain	Shunt = 1.0 mΩ, current sense amplifier gain = 20. V _{Isns} – V _{Isns_offset} is positive when current enters the inverter		20		mV/A
G _{V_{sns}}	Phase and DC voltage sense gain ⁽³⁾			40.5		mV/V

(1) Maximum current depends on die temperature – actual maximum current is affected by switching frequency, bus voltage and thermal cooling. Refer to EPC2206 for details.

(2) All phases over-current is monitored. Over-current signal is sent to the controller connector via R60. Insert JOCPn to disable PWM when over-current is detected

(3) **Maximum dynamic voltage range is 0 V to 81.5 V which exceeds maximum recommended supply voltage for the EPC2206 eGaN IC.**

(4) Higher frequency operation up to 500 kHz in DC–DC mode is possible.

HIGHLIGHTED PARTS

Power Stage

The EPC9145 features a 3-phase inverter with EPC2206 eGaN FET and gate drivers. For more information on the EPC2206 please refer to the datasheet available from EPC at www.epc-co.com. The datasheet should be read in conjunction with this quick start guide.

Onboard power supply

The EPC9145 board includes logic and gate driver house-keeping power supplies that are powered from the main input supply voltage to the inverter board. The 3.3 V controller supply voltage is also provided to the controller connector (J60) and can be disconnected by removing a resistor (R803).

Current and voltage sense

The EPC9145 inverter is equipped with voltage and current sense for all phases and voltage sense for the DC input.

Output current is measured in-line using a 1.0 mΩ shunt (Fx_Rsp1) that is amplified using the INA240A1 (CSx_U1) bi-directional current sense amplifier that yields a total gain of 20 mV/A. The bandwidth of the current sense amplifier is 400 kHz which is adequate for accurate motor control operation at 100 kHz switching frequency.

The output current can be also measured using 4x 4.0 mΩ leg shunts (equivalent to 1.0 mΩ leg shunt) that are amplified with a total gain of 20 mV/A and an offset of 1.65 V. By inserting the jumper (Jsnsx) in proper position, the user can choose seamlessly between in-phase or leg shunt current sensing. In all configurations, the shunt amplifiers are bi-directional ensuring the full four quadrant operation is covered.

The main input DC supply voltage and each phase voltage are measured using a resistor divider network that yields a total gain of 40.5 mV/V.

Temperature sensor

The EPC9145 board is equipped with a temperature sensor (U40 – AD590) that is centrally located under the heatsink that reports an analog voltage reading proportional to the measured temperature using the following equation :

$$T = \left(\frac{V \cdot 1000}{7.87} \right) - 273.16 \text{ [}^\circ\text{C]}$$

For optimal temperature reporting of the heatsink, a thermal interface material (TIM) can be added between the sensor and the heatsink. See the Thermal section for suitable TIM recommendations.

Connection and controller mate options

A 40 pin connector is used to interface power, PWM signals and analog feedback signals between the interface control board and the EPC9145 motor drive inverter. Table 4 gives the map (J60) for each signal.

LED indicators

The EPC9145 has a number of LED indicators indicating the presence of the various supply voltages as follows:

- 5 V LED (**orange**) – indicates the 5 V supply is operational
- 3.3 V LED (**yellow**) – indicates the 3.3 V supply is operational

Table 2: Controller interface connection (J60) pin allocation map

Pin #	Pin name		Pin #
2	PWMH1	GND	1
4	PWML1	GND	3
6	PWMH2	GND	5
8	PWML2	GND	7
10	PWMH3	3V3 ⁽¹⁾	9
12	PWML3	3V3 ⁽¹⁾	11
14	EncA	3V3 ⁽¹⁾	13
Index Slot			
18	EncB	AGND	17
20	EncI	AGND	19
22	Vdc	AGND	21
24	Vsns1	AGND	23
26	Vsns2	AGND	25
28	Vsns3	AGND	27
30	N.C.	AGND	29
32	Isns1	AGND	31
34	Isns2	AGND	33
36	Isns3	AGND	35
38	EN/Pgood	OC_FLT/ ⁽²⁾	37
40	Tsns	LEDact	39

⁽¹⁾ 3.3 V is connected through the resistor R803 (installed by default)

⁽²⁾ OC_FLT/ is connected through the resistor R803 (not installed by default)

Test Points

A number of test-points are available for easy measurement of various nodes as follows:

- Touch-point pad for the 5 V supply
- Touch-point pad for the 3.3 V supply
- Touch-point pad for the Over-current detect
- A SMD hookup for each phase voltage
- A Touch-point pad for each amplified current signal (after jumper choice)
- Touch-point pad for the shaft encoder A or Hall_A signal
- Touch-point pad for the shaft encoder B or Hall_B signal
- Touch-point pad for the shaft encoder Index or Hall_C signal

All analog signals are measured with respect to analog ground (AGND) using a Touch/point pad. All digital signals are measured with respect to digital ground (GND) using

a SMD hookup. All the test point locations are shown in figure 3.

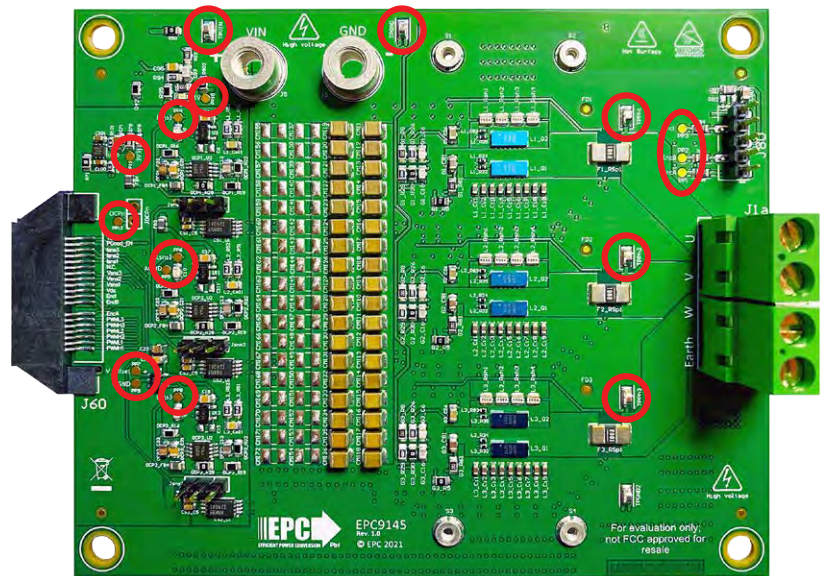

Figure 3: EPC9145 test point pad and hookup locations and designations

Over-current protection

The EPC9145 includes an overcurrent detect circuit that triggers if any of the three phases current measurement exceeds 50 A. Once an over-current is triggered, the active low OC signal will remain low for a short period of time, determined by the RC time constant (3.6 μs) of R29 and C16 and all PWM signals will be disconnected to the gate drivers if jumper JOCPn is installed. The OC detect signal can be passed on to the controller as OC_FLT\ through R60 (installed by default). The OC signal should not be loaded by the controller and a high input impedance circuit must be used to read the status. Loading the OC signal will affect the reset time or could place the inverter in permanent over-current state.

Jumper Settings

The EPC9145 is provided with two jumpers with functions given in table 3.

Table 3: Jumper settings function

Jumper	Installed	Open
JOCPn	The over-current detection circuit disables the PWM signals independently from microcontroller	The over-current detection circuit does not disable the PWM signals independently from microcontroller. In this case R60 must be mounted and the microcontroller must promptly react to over-current detection
Jsnx	Position 1-2 leg shunt current sensing analog signal selected Position 2-3 in phase current sensing analog signal selected (Pin 3 of Jsnx is near control connector)	Not recommended. The jumpers Jsns1, Jsns2 and Jsns3 must be installed in any of the two possible positions.

Any combination of valid position settings may be selected.

Jumper Settings (continued)

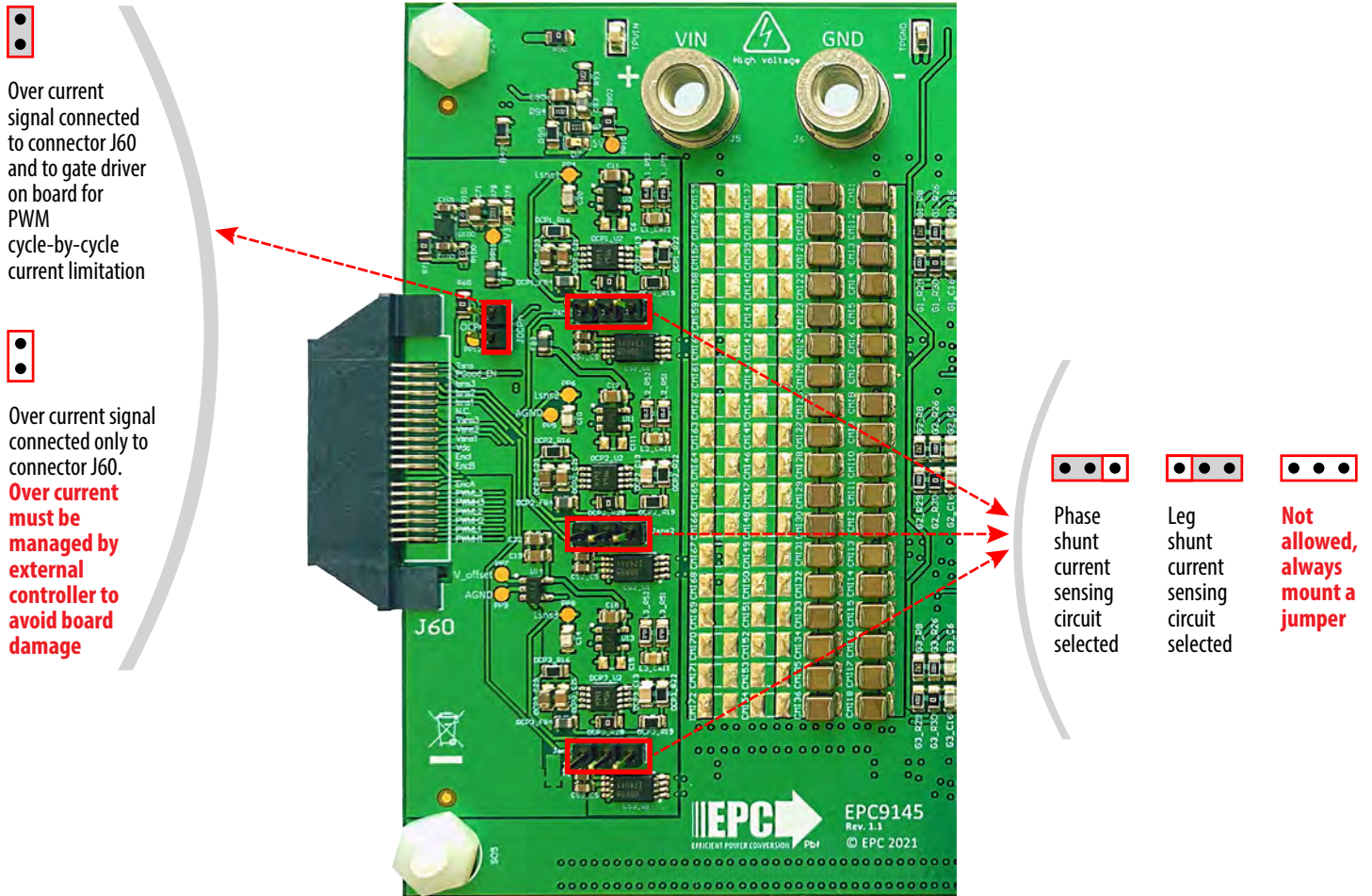

Figure 4: Over-current and current sensing circuits jumper settings

Shaft Encoder / Hall effect sensors

Connector (J80) is used to connect a shaft sensor to the EPC9145 motor drive inverter that is compatible with optical quadrature encoders or hall effect sensors and provides supply voltage for the encoder. The available voltage selections can be made by installing the applicable resistors as follows: 5 V using R81 (default), and 3.3 V using R82. The filtered signals are then provided to the controller connector (J60).

Compatible Controllers

A list of compatible motor drive inverter to the EPC9145 is given in table 2.

Table 4: Compatible controller interface and controller boards to the EPC9145

Controller Board Number	Controller Manufacturer	Controller	Target Application
EPC9147A - Rev. 2.1	Microchip - MA330031-2	dsPIC33EP256MC506	Motor Drive
EPC9147B ¹ - Rev. 1.0	Texas Instruments - LAUNCHXL-F28379D	TMS320F2837xD	Motor Drive
EPC9147C ¹ - Rev. 1.0	ST Microelectronics	NUCLEO-G431RB / NUCLEO-G474RE	Motor Drive
EPC9147E - Rev. 2.0	Generic Interface board	N/A	Motor Drive or DC–DC converter
EPC9528 - Rev. 3.0	Generic controller board	dsPIC33CK256MP503	DC–DC converter

¹Available soon

APPLICATION CONFIGURATIONS

The EPC9145 power board can be used for a number of different applications.

Motor Drive Inverter

A 3-phase BLDC motor drive inverter is the primary application case for which the EPC9145 board was designed for and can be used for either sensor-less or shaft encoder sensor configurations. The motor drive controller options are given in table 2 giving the user various mainstream choices that leverage existing resources to simplify and speed up development and evaluation. Figure 5 shows the simplicity of connecting a controller and motor to the EPC9145. **In the default configuration, the EPC9145 is paired with the EPC9147C that is pre-programmed to power and control a NEMA 34 size motor from Teknic M-3411P-LN-08D, with DC supply voltage of 48 V using sensor-less field orientation control with space vector pulse width modulation (SVPWM).**

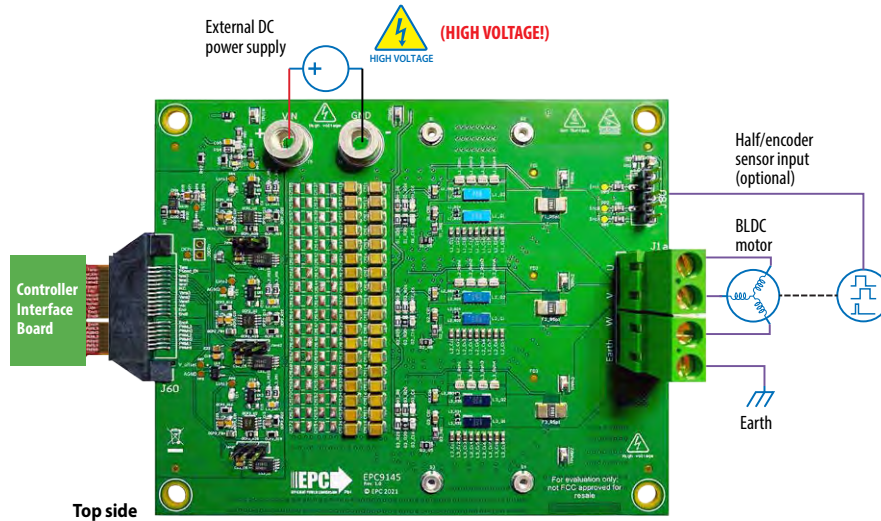

Figure 5: Connection diagram of the EPC9145 configured as a motor drive inverter

Multi-phase Synchronous Buck Converter

The EPC9145 can also be configured as multi-phase synchronous buck converter with either 2 or 3 phase options. When configured as a 2-phase converter, the user can choose any combination of output but should make use of the applicable on-board inductor pad allocations, with appropriate value for the inductor at the chosen operating frequency. **In this configuration it is important to removed the Y-capacitor (CY) and short out the pads with a conductor that can carry the full rated load current.** The earth connection then becomes the ground (GNDP) return as shown in Figure 6. The output voltage can be measured using any of the phase voltage test points with respect to the ground (GNDP).

EPC9528 controller is best suited to control the EPC9145 as a DC-DC converter.

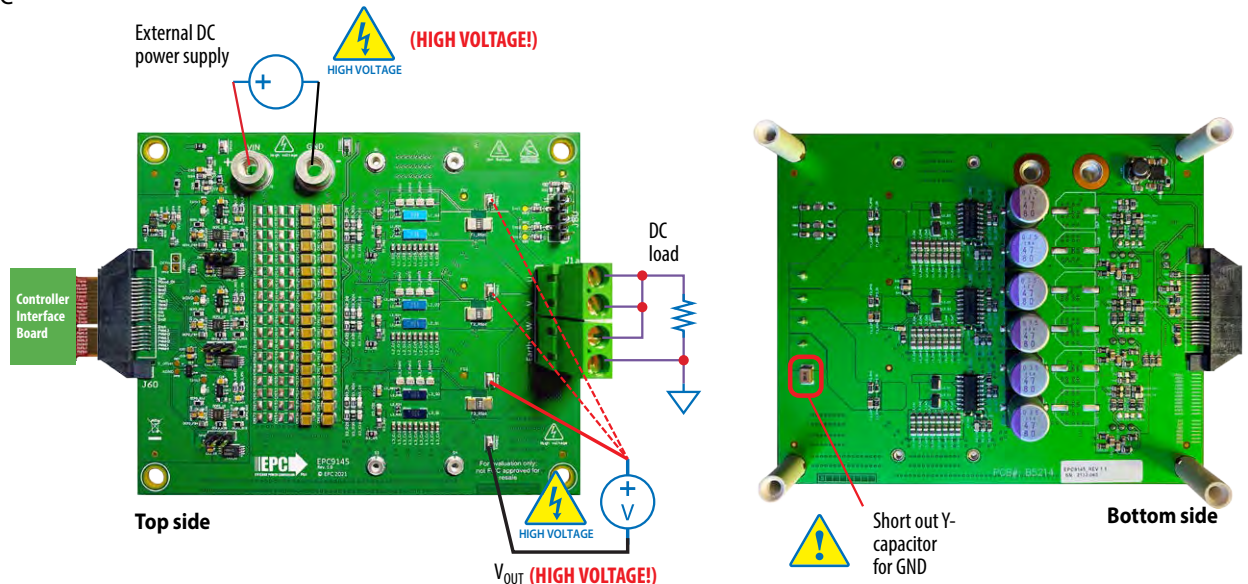
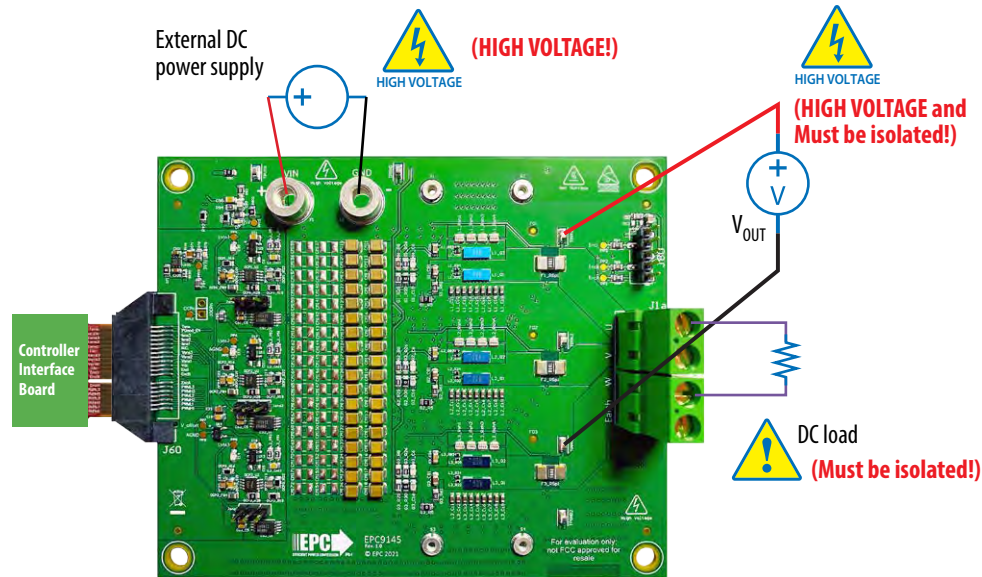

Figure 6: Connection diagram of the EPC9145 configured as a multi-phase converter

Full-Bridge Synchronous Buck Converter

The EPC9145 can also be configured as full bridge converter where any two of the three phases can be used. A full bridge connection example is shown in Figure 7. Since the full-bridge converter is not specifically referenced to the ground (GNDP), the user must take appropriate measures to ensure the correct load connection. The output voltage can be measured using the applicable phase voltage test points (TP5, TP6, or TP7). The user must ensure that the measurement system is isolated for this type of measurement. Alternatively the output voltage can also be measured using the same technique given in Figure 7, using the common ground (GNDP) and subtracting the one signal from the other.

EPC9528 controller is best suited to control the EPC9145 as a DC-DC converter.



Top side

Figure 7: Connection diagram of the EPC9145 configured as a full bridge converter

QUICK START PROCEDURE

For this quick start procedure only the motor drive application using the EPC9147A controller is presented.

Follow the procedure below to operate a motor with EPC9145 and controller board:

1. Mate the EPC9145 with an applicable controller interface board as given in table 4. Review the QSG of corresponding control interface board for detailed operating procedures.
2. Connect the correct motor, whose parameters are programmed into the controller, to the EPC9145 at connector J1 and the DC power supply at connectors J5 and J6 (**Observe correct polarity, there is no inverse polarity protection on board**) and shown in Figure 5.
3. Preset the main supply voltage to the operating voltage and turn on and observe the power LEDs illuminate. Press the Start/Stop button to start the motor spinning. **Note that user interface (buttons and knob) are not isolated, so use appropriate precautions when dealing with high voltage.**
4. Once operational, make the necessary measurements.
5. For shutdown, press the Start/Stop button to stop the motor spinning, then turn off the main DC power supply.

THERMAL CONSIDERATIONS

The EPC9145 is intended for bench evaluation at room ambient temperatures and under either natural convection or forced air cooling. The addition of a heatsink can significantly improve the heat dissipation from the eGaN FETs and increase the current capacity of these devices, while ensuring to not exceed the absolute maximum die temperature of 150°C.

The EPC9145 board is equipped with four mechanical spacers (S1, S2, S3, S4) that can be used to easily attach a standard quarter-brick converter heatsink as shown in figures 8 and 9, and only requires a thermal interface material (TIM), a heatsink, and screws.

The heatsink is held in place using screws that fasten to the mechanical spacers which will accept 6 mm long M2 x 0.4 mm thread screws such as McMasterCarr 95836A109.

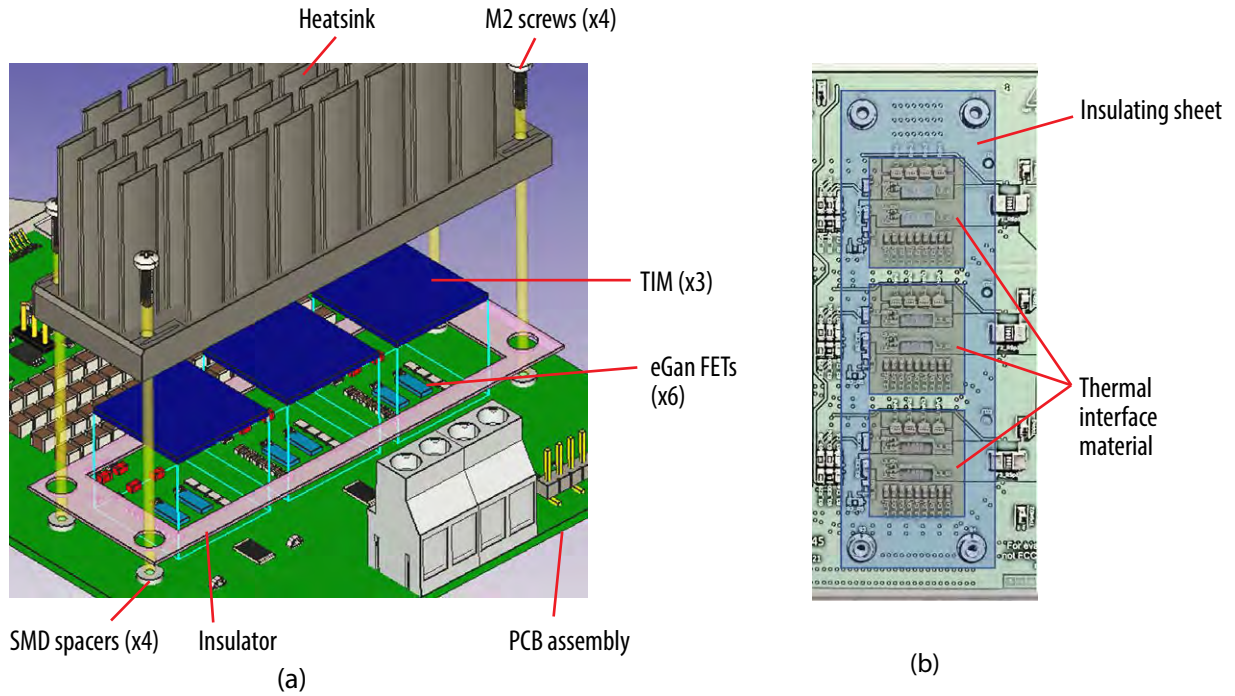

Figure 8: Details for attaching a heatsink to the board. (a) exploded 3D perspective, (b) top view showing the insulator sheet details with opening for the TIM with location of the eGaN FETs

When assembling the heatsink, it is necessary add a thin insulating layer to prevent the heat-spreader from short circuiting with components that have exposed conductors such as capacitors and resistors, as shown in figures 8 and 9. Note that the heatsink is ground connected. A rectangular opening in the insulator must be provided to allow the TIM to be placed over the FETs to be cooled with a minimum clearance of 3 mm on each side of the rectangle encompassing the FETs. The TIM will then be similar in size or slightly smaller than the opening in the insulator shown by the red dashed outline in figure 9. The insulator sheet material is made by Laird P/N A14692-30 Tgard K52 with thickness of 0.051 mm (0.0020”).

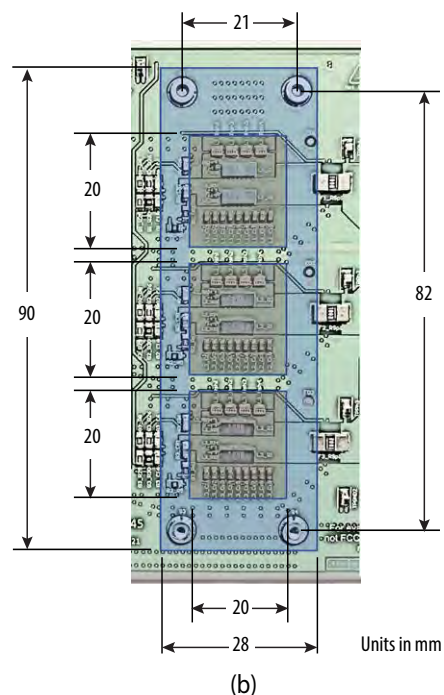

Figure 9: (a) minimum TIM coverage area (b) Insulator sheet details

A TIM is added to improve the interface thermal conductance between the GaN ICs and the attached heatsink. The choice of TIM needs to consider the following characteristics:

- **Mechanical compliance** – During the attachment of the heat spreader, the TIM underneath is compressed from its original thickness to the vertical gap distance between the spacers and the FETs. This volume compression exerts a force on the FETs. A maximum compression of 2:1 is recommended for maximum thermal performance and to constrain the mechanical force which maximizes thermal mechanical reliability.
- **Electrical insulation** – The backside of the eGaN FET is a silicon substrate that is connected to source and thus the upper FET in a half-bridge configuration is connected to the switch-node. To prevent short-circuiting the switch-node to the grounded thermal solution, the TIM must be of high dielectric strength to provide adequate electrical insulation in addition to its thermal properties.
- **Thermal performance** – The choice of thermal interface material will affect the thermal performance of the thermal solution. Higher thermal conductivity materials is preferred to provide higher thermal conductance at the interface.

EPC recommends the following thermal interface materials:

- **t-Global** P/N: TG-A1780 x 0.5 mm (highest conductivity of 17.8 W/m-K)
- **t-Global** P/N: TG-A6200 x 0.5 mm (moderate conductivity of 6.2 W/m-K)
- **Bergquist** P/N: GP5000-0.02 (~0.5 mm with conductivity of 5 W/m-K)
- **Bergquist** P/N: GPTGP7000ULM-0.020 (conductivity of 7 W/m-K)

The default TIM used for the EPC9145 is made by t-Global Technology, measures 20 mm x 20 mm x 0.5 mm thick with P/N TG-A6200-20-20-0.5

There are two heatsink options for the EPC9145 that depends on the type of cooling used. For natural convection a taller heatsink is used while a lower profile heatsink with more fins is used for force air cooling as shown in figure 10.

The natural convection cooling heatsink used for the EPC9145 is Alpha Novatech, Inc., model # LPD2790-35BM-3V6; the forced air cooling heatsink is made by **Advanced Thermal Solutions, model # ATS-2862-C1-R0**.

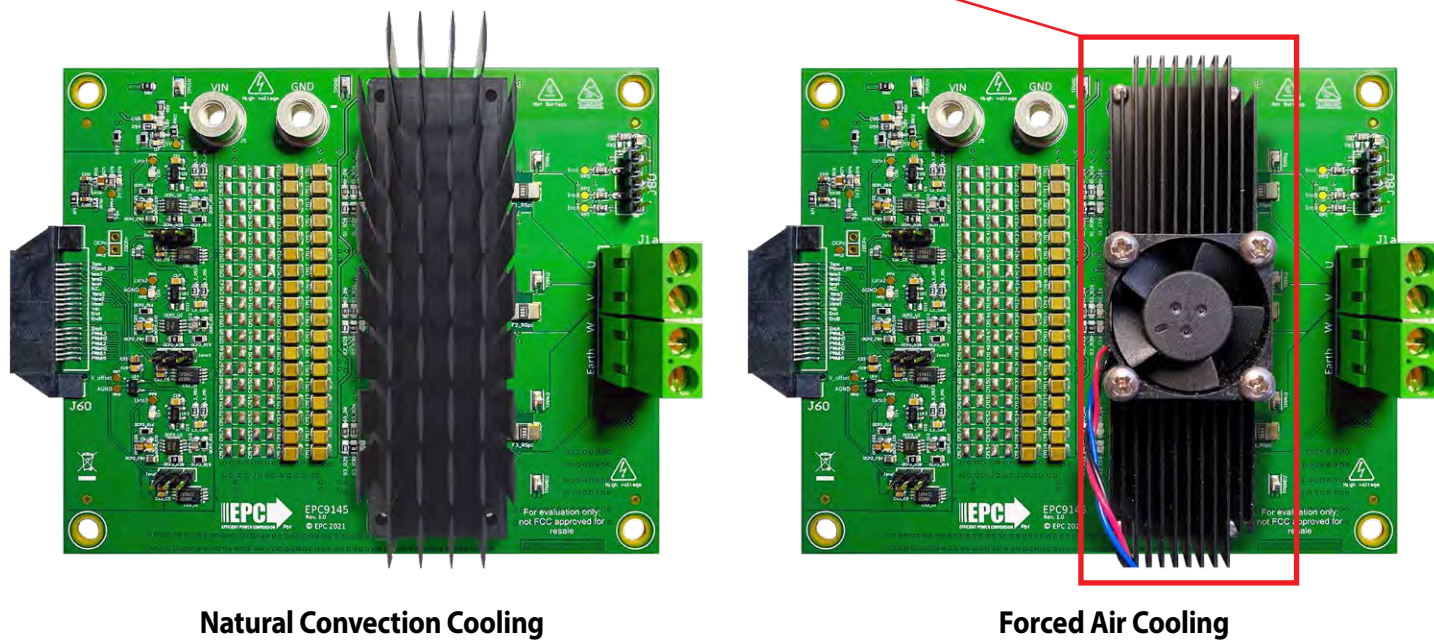

Natural Convection Cooling

Forced Air Cooling

Figure 10: Natural convection cooling and force air cooling heatsink options installed on the EPC9145 inverter board

EXPERIMENTAL VALIDATION EXAMPLE

The EPC9145 motor drive inverter, paired with the EPC9147A interface controller, was operated from a 48 V_{DC} supply voltage while switching at 100 kHz, 21 ns dead-time setting, powering a 400 W NEMA 34 motor with a sinusoidal modulation frequency of 26.4 Hz and delivering up to 10 A_{RMS} into each phase of the motor.

MEASURED PHASE LEG WAVEFORMS

The measured waveforms of the motor phase current and phase-to-phase voltage while the EPC9145 is delivering 10 A_{RMS} into each motor phase is shown in figure 11.

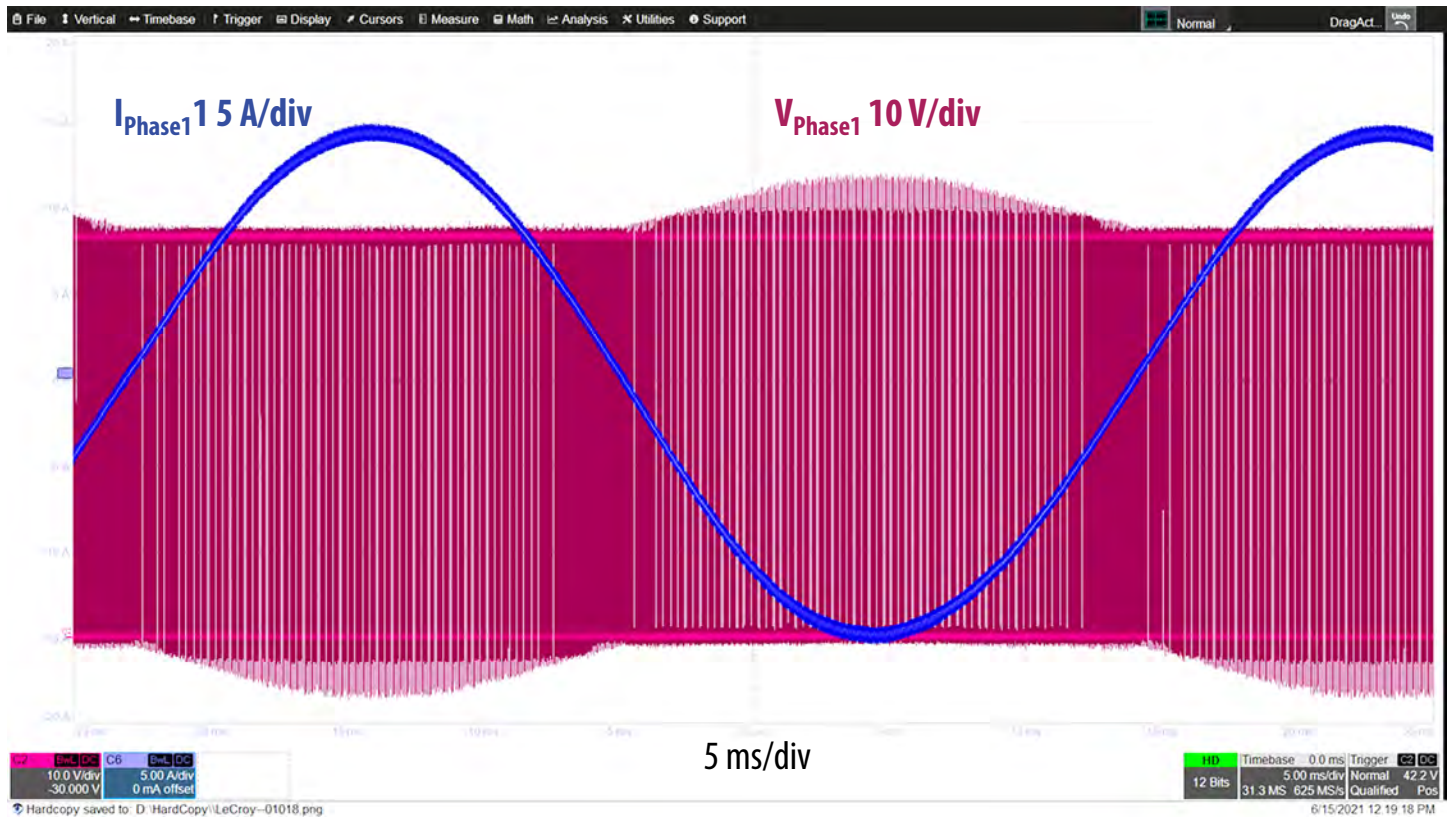

Figure 11. Phase 1 current and phase 1 to phase 2 voltage reference to PGND

THERMAL PERFORMANCE

The thermal performance summary of the EPC9145 board is given in Table 5. When operated on a motor bench at ambient temperature of 25°C, with 48 V_{DC} supply and natural convection, the board can deliver 10 A_{RMS} per phase without a heatsink and 20 A_{RMS} per phase with a heatsink attached with a temperature rise below 50°C from eGaN FET case to ambient.

Table 5: Motor drive operating points at PWM = 40 kHz, deadtime = 50 ns, with and without heatsink at 22 °C ambient temperature

V _{IN} (V)	Heatsink Installed	PWM (kHz)	Deadtime (ns)	I _{Phase} (A _{RMS})	PCB bottom Temperature	Heatsink Temperature	eGaN FET Case Temperature (°C)
48	No	100	50	5	44.8	--	44.7
48	No	100	50	10.4	60.6	--	57.9
60	No	100	50	5.1	45.6	--	46
60	No	100	50	10.4	66.2	--	65.2
60	No	100	50	16.4	75	--	74.5
48	Yes passive	100	50	5.1	37.8	36.6	< 37.8 (*)
48	Yes passive	100	50	10.1	52.5	48.7	< 52.5 (*)
48	Yes passive	100	50	17	63.6	56.4	< 63.6 (*)
48	Yes passive	100	50	25	85	70.5	< 85.0 (*)
60	Yes passive	100	50	5.1	42.2	40.7	< 42.2 (*)
60	Yes passive	100	50	10.3	54.8	50	< 54.8 (*)
60	Yes passive	100	50	16.1	58.4	52	< 58.4 (*)
48	Yes passive	20	50	10	36.3	35	< 36.3 (*)
48	Yes passive	20	50	20	57.1	52	< 57.1 (*)
48	Yes passive	20	50	24.9	70	61.8	< 70.0 (*)

(*) With heatsink, junction temperature has not measured directly.

The graph in Figure 12 shows the correlation between the thermal couple measured temperature beneath the phase-2 eGaN FETs on the bottom side of the PCB and the infra-red camera die case temperature for same eGaN IC that is measured without a heatsink and with only natural convection cooling. Figure 13 shows the location of the thermal couple used to measure the bottom side of the PCB temperature.

POWER CONSUMPTION

When running the board in a motor drive application, the power consumption depends on the PWM switching frequency, the input voltage, the phase current and the die case temperature.

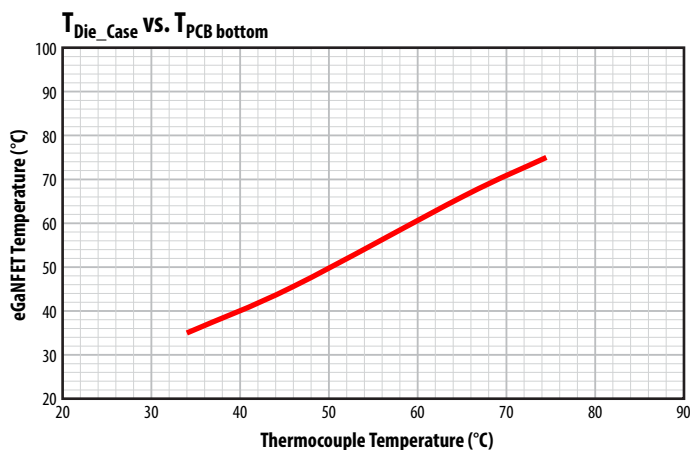

Figure 12: eGaN FET case temperature vs. thermocouple temperature on bottom of the PCB. Operation under natural convection without heatsink

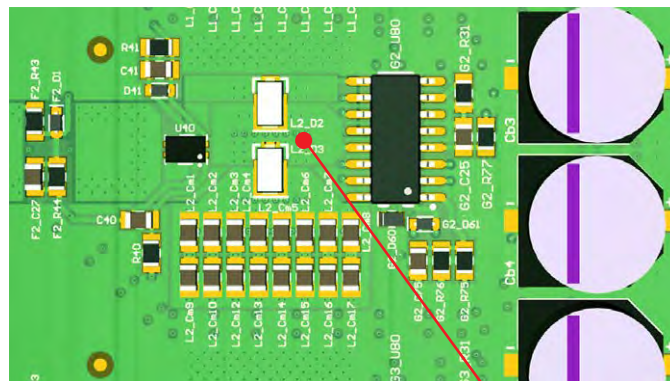

Figure 13: Thermocouple location on the bottom side of the PCB

Table 6: Bill of Materials

Item	Qty	Reference	Part Description	Manufacturer	Part #
1	9	C5, C6, C7, C12, C15, C111, OCP1_C9, OCP2_C9, OCP3_C9	CAP CER 1000 pF 100 V X7R 0805, CAP CER 1000 pF 50 V X7R 0805, CAP FILM 1000 pF 5% 16 VDC 0603	TDK AVX Panasonic	C2012X7R2A103K085AM, 08055C102KAT2A, ECH-U1C102JX5
2	3	C10, C14, C20	CAP CER 47 pF 50 V COG/NP0 0805	KEMET	C0805C470J5GACTU
3	7	C11, C17, C18, C19, OCP1_C21, OCP2_C21, OCP3_C21	CAP CER 0.1 μF 100 V X7R 0805	KEMET	C0805C104K1RACTU
4	4	C22, OCP1_C23, OCP2_C23, OCP3_C23	CAP CER 2.2 μF 25 V X7R 0805	TDK	CGA4J3X7R1E225K125AD
5	4	C24, L1_Cm11, L2_Cm11, L3_Cm11	CAP CER 1000 pF 50 V X7R 0805	AVX	08055C102KAT2A
6	5	C40, C41, CS1_C3, CS2_C3, CS3_C3	CAP CER 0.1 μF 50 V X7R 0805	AVX	08055C104KAT2A
7	2	C60, C71	CAP CER 22 μF 16 V X5R 0805	TDK	C2012X5R1C226K125AC
8	1	C80	CAP CER 4.7 μF 25 V X7R 0805	TDK	CGA4J1X7R1E475K125AC
9	9	C85, C86, C87, OCP1_C8, OCP1_C13, OCP2_C8, OCP2_C13, OCP3_C8, OCP3_C13	CAP FILM 1000 pF 5% 16 VDC 0603	Panasonic	ECH-U1C102JX5
10	1	C90	CAP CER 0.22 μF 100 V X7S 0805	TDK	C2012X7S2A224M085AE
11	1	C91	CAP CER 1 μF 25 V X5R 0805	TDK	C2012X5R1E105K125AA
12	9	C92, C95, C700, CS1_C4, CS2_C4, CS3_C4, F1_C27, F2_C27, F3_C27	CAP CER 1000 pF 100 V X7R 0805	TDK	C2012X7R2A103K085AM
13	1	C93	CAP CER 3300 pF 100 V COG 0805	TDK	C2012C0G1A332J125AA
14	7	C94, G1_C25, G1_C26, G2_C25, G2_C26, G3_C25, G3_C26	CAP CER 10 μF 25 V X5R 0805	Samsung	CL21A106KPLQNC
15	2	C100, C101	CAP CER 1 μF 25 V X7R 0603	TDK	C1608X7R1E105K080AB
16	6	Cb1, Cb2, Cb3, Cb4, Cb5, Cb6	Electrolytic Cap	Panasonic	80SXV47M
17	6	Cb7, Cb8, Cb9, Cb10, Cb11, Cb12	Electrolytic Cap	Panasonic	80SXV47M
18	36	CMI1, CMI2, CMI3, CMI4, CMI5, CMI6, CMI7, CMI8, CMI9, CMI10, CMI11, CMI12, CMI13, CMI14, CMI15, CMI16, CMI17, CMI18, CMI19, CMI20, CMI21, CMI22, CMI23, CMI24, CMI25, CMI26, CMI27, CMI28, CMI29, CMI30, CMI31, CMI32, CMI33, CMI34, CMI35, CMI36	CAP CER 10 μF 100 V X7S 1210	Murata	GRM32EC72A106KE05L
19	36	CMI37, CMI38, CMI39, CMI40, CMI41, CMI42, CMI43, CMI44, CMI45, CMI46, CMI47, CMI48, CMI49, CMI50, CMI51, CMI52, CMI53, CMI54, CMI55, CMI56, CMI57, CMI58, CMI59, CMI60, CMI61, CMI62, CMI63, CMI64, CMI65, CMI66, CMI67, CMI68, CMI69, CMI70, CMI71, CMI72	CAP CER 10 μF 100 V X7S 1210	Murata	GRM32EC72A106KE05L
20	6	CS1_C1, CS1_C5, CS2_C1, CS2_C5, CS3_C1, CS3_C5	CAP CER 0.1 μF 25 V X7R 0603	TDK	C1608X7R1E104K080AA
21	3	CS1_C2, CS2_C2, CS3_C2	CAP CER 3.3 μF 16 V X5R 0603	TDK	C1608X5R1C335K080AC
22	8	CS1_FB1, CS2_FB1, CS3_FB1, FB3, FB4, OCP1_FB4, OCP2_FB4, OCP3_FB4		Murata	BLM21BD182SN1D
23	6	CS1_R1, CS1_R2, CS2_R1, CS2_R2, CS3_R1, CS3_R2	RES 10 Ω 1/8 W 0805	Vishay	RCA080510R0FKEA
24	3	CS1_R3, CS2_R3, CS3_R3	RES 100 Ω 1/8 W 0805	Yageo	RC0805FR-07100RL
25	3	CS1_U1, CS2_U1, CS3_U1	Current Sense Amplifier	TI	INA240A1PWR
26	1	CY	CAP CER 4700PF 250VAC X7R 1812	Murata	GA343DR7GD472KW01L
27	1	D7	LED ORANGE 0603	Lite-On	LTST-C193KFKT-5A
28	4	D41, D85, D86, D87	3.6 V Zener Diode	Diodes Inc.	BZT52C3V6T-7
29	1	D78	LED YELLOW CLEAR CHIP SMD	Lite-On	LTST-C193KSKT-5A
30	4	D701, F1_D1, F2_D1, F3_D1	Diode Schottky 30 V 30 mA	Diodes Inc.	SDM03U40
31	4	F1_R43, F2_R43, F3_R43, R701	RES 100 kΩ 1/4 W 0805	Panasonic	ERA-6AEB104V
32	4	F1_R44, F2_R44, F3_R44, R700	RES 4.22 kΩ 0.1% 1/8 W 0805	Yageo	RT0805BRD074K22L
33	3	F1_RSp1, F2_RSp1, F3_RSp1	RES 0.001 Ω 1% 3W 2512	Bourns	CRE2512-FZ-R001E-3
34	6	G1_C6, G1_C75, G2_C6, G2_C75, G3_C6, G3_C75	CAP CER 100 pF 50 V COG/NP0 0805	AVX	08055A101JAT2A
35	3	G1_C16, G2_C16, G3_C16	CAP CER 360 pF 50 V COG/NP0 0805	KEMET	C0805C361J5GACTU
36	3	G1_C81, G2_C81, G3_C81	CAP CER 10 μF 25 V X7R 0805	Samsung	CL21A106KPLQNC
37	3	G1_D60, G2_D60, G3_D60	DIODE ZENER 5.61 V 500 mW SOD523	On Semi	MM5Z5V6S1T1G
38	3	G1_D61, G2_D61, G3_D61	Schottky Diode 100 V 200 mA	ST	BAT41KIFILM
39	26	G1_R5, G1_R30, G1_R31, G2_R5, G2_R30, G2_R31, G3_R5, G3_R30, G3_R31, OCP1_R4, OCP1_R18, OCP1_R28, OCP2_R4, OCP2_R18, OCP2_R28, OCP3_R4, OCP3_R18, OCP3_R28, R40, R60, R71, R81, R90, R800, R802, R803	RES 0 Ω JUMPER 1/8 W 0805	Stackpole	RMCF0805ZTOR00
40	9	G1_R8, G1_R61, G1_R75, G2_R8, G2_R61, G2_R75, G3_R8, G3_R61, G3_R75	RES 2.2 Ω 0.4 W 0805	ROHM	ESR10EZPJ2R2

Table 6: Bill of Materials (continued)

Item	Qty	Reference	Part Description	Manufacturer	Part #
41	12	G1_R26, G1_R29, G1_R76, G2_R26, G2_R29, G2_R76, G3_R26, G3_R29, G3_R76, R6, R14, R66	RES 10kΩ 1/4W 0805	Stackpole	RNCP0805FTD10K0
42	12	G1_R77, G2_R77, G3_R77, L1_R51, L1_R52, L2_R51, L2_R52, L3_R51, L3_R52, R13, R23, R33	RES 10 Ω 1/8W 0805	Stackpole	RNCF0805AKT10R0
43	3	G1_U80, G2_U80, G3_U80	600 V GaN FET Half-bridge gate driver	ST Microelectronics	STDRIIVEG600
44	2	J1a, J1b	TERM BLK 2P SIDE ENT 6.35 mm PCB	TE Connectivity	796740-2
45	2	J5, J6	TERM REDCUBE M5 SMD		7466005R
46	1	J60	CONN EDGE DUAL FEMALE 40 POS 0.039	Samtec	MEC1-120-02-F-D-EM2
47	1	J80	Header Male 100mil 1 row, 5 pos., Thru Vert.	Samtec	TSM-105-01-L-SV
48	1	JOCPn	CONN HEADER VERT 2 POS 2.54 mm	Tyco	4-103185-0-02
49	4	JP1, JP2, JP3, JP5	100 mil Jumper Black	Würth Electronics	60900213421
50	3	Jsns1, Jsns2, Jsns3		Tyco	4-103185-0-03
51	27	L1_Ci1, L1_Ci2, L1_Ci3, L1_Ci4, L1_Ci5, L1_Ci6, L1_Ci7, L1_Ci8, L1_Ci9, L2_Ci1, L2_Ci2, L2_Ci3, L2_Ci4, L2_Ci5, L2_Ci6, L2_Ci7, L2_Ci8, L2_Ci9, L3_Ci1, L3_Ci2, L3_Ci3, L3_Ci4, L3_Ci5, L3_Ci6, L3_Ci7, L3_Ci8, L3_Ci9	CAP CER 0.22 μF 100 V X7S 0603	Taiyo Yuden	HMK107C7224KAHTE
52	48	L1_Cm1, L1_Cm2, L1_Cm3, L1_Cm4, L1_Cm5, L1_Cm6, L1_Cm7, L1_Cm8, L1_Cm9, L1_Cm10, L1_Cm12, L1_Cm13, L1_Cm14, L1_Cm15, L1_Cm16, L1_Cm17, L2_Cm1, L2_Cm2, L2_Cm3, L2_Cm4, L2_Cm5, L2_Cm6, L2_Cm7, L2_Cm8, L2_Cm9, L2_Cm10, L2_Cm12, L2_Cm13, L2_Cm14, L2_Cm15, L2_Cm16, L2_Cm17, L3_Cm1, L3_Cm2, L3_Cm3, L3_Cm4, L3_Cm5, L3_Cm6, L3_Cm7, L3_Cm8, L3_Cm9, L3_Cm10, L3_Cm12, L3_Cm13, L3_Cm14, L3_Cm15, L3_Cm16, L3_Cm17	CAP CER 1 μF 100 V X7S 0805	TDK	CGA4J3X7S2A105M125AB
53	6	L1_D2, L1_D3, L2_D2, L2_D3, L3_D2, L3_D3	DIODE SCHOTTKY 100 V 2 A	Vishay	SS2PH10-M3
54	6	L1_Q1, L1_Q2, L2_Q1, L2_Q2, L3_Q1, L3_Q2	eGaN FET N-CH 80 V 90 A	EPC	EPC2206
55	6	L1_R32, L1_R35, L2_R32, L2_R35, L3_R32, L3_R35	RES SMD 10 Ω 1% 1/10 W 0402	Panasonic	ERJ-2RK1F10R0X
56	6	L1_R34, L1_R83, L2_R34, L2_R83, L3_R34, L3_R83	RES SMD 1 Ω 1% 1/16 W 0402	ROHM	MCR01MRT1JR0
57	12	L1_RSh1, L1_RSh2, L1_RSh3, L1_RSh4, L2_RSh1, L2_RSh2, L2_RSh3, L2_RSh4, L3_RSh1, L3_RSh2, L3_RSh3, L3_RSh4	RES 0.004 Ω 1 W 0805 WIDE	Susumu	KRL2012E-M-R004-F-T5
58	1	L90		Murata	MDH6045C-221MB=P3
59	7	OCP1_R9, OCP1_R39, OCP2_R9, OCP2_R39, OCP3_R9, OCP3_R39, R68	RES 110 kΩ 1/4 W 0805	Stackpole	RMCF0805FT110K
60	5	OCP1_R12, OCP2_R12, OCP3_R12, R82, R801	RES 10 kΩ 1/4 W 0805, RES 0 Ω JUMPER 1/8 W 0805	Stackpole	RNCP0805FTD10K0, RM-CF0805ZT0R00
61	6	OCP1_R16, OCP1_R22, OCP2_R16, OCP2_R22, OCP3_R16, OCP3_R22	RES 1.27 kΩ 0.1% 1/4 W 0805	Panasonic	ERA-6AEB1271V
62	6	OCP1_R19, OCP1_R24, OCP2_R19, OCP2_R24, OCP3_R19, OCP3_R24	RES 8.06 kΩ 0.1% 1/4 W 0805	Panasonic	ERA-6AEB8061V
63	3	OCP1_U2, OCP2_U2, OCP3_U2	Dual Comparator	Texas Instruments	TLV7022DGKR
64	1	R7	RES 2.2 kΩ 1/8 W 0805	TE	CRG0805F2K2
65	6	R10, R17, R20, R27, R36, R37	RES 10 kΩ 1/4 W 0805	Panasonic	ERA-6AEB203V
66	12	R11, R15, R21, R25, R31, R38, R84, R85, R86, R87, R88, R89	RES 1 kΩ 1/4W 0805, RES 1 kΩ JUMPER 1/4 W 0805	Stackpole	RNCP0805FTD1K00
67	2	R41, R92	RES 7.87 kΩ 0.1% 1/4 W 0805	Panasonic	ERA-6AEB7871V
68	1	R42	RES 332 kΩ 0.01% 1/8 W 0805	Panasonic	ERA-6AEB3323V
69	1	R78	RES 330 Ω 1/4 W 0805	TE	CRG0805F330R
70	1	R91	RES 43.2 kΩ 0.01% 1/8 W 0805	Yageo	RC0805FR-0743K2L
71	1	R93	RES 51 kΩ 1/8 W 0805	TE	CRG0805F51K
72	1	R94	RES 11.3 kΩ 0.1% 1/8 W 0805	Panasonic	ERJ-6ENF1132V

Table 6: Bill of Materials (continued)

Item	Qty	Reference	Part Description	Manufacturer	Part #
73	1	R95	RES 3.65 kΩ 0.1% 1/8 W 0805	Panasonic	ERA-6AEB3651V
74	1	R100, R101	RES SMD 0 Ω JUMPER 1/10 W 0603	Panasonic	ERJ-3GEY0R00V
75	1	S1, S2, S3, S4	ROUND STANDOFF M2X0.4 STEEL 1mm	Würth	9774010243R
76	4	SO4, SO5, SO6, SO7	8834 Nylon Standoff	Keystone	8834
77	4	TPGND, TPGND2, TPPh1, TPPh2, TPPh3, TPVIN	PC TEST POINT MINIATURE	Keystone	5015
78	1	U3, U11, U13	50 MHz 200 uV r-to-r 5 V Operational Amplifier	ST Microelectronics	TSV791ILT
79	6	U14	Operational Amplifier rail to rail low power	ST Microelectronics	TSV321RILT
80	3	U40	Temperature Sensor -40C-125C 4LFCSP	Analog	AD590JCPZ-R5
81	1	U90	IC REG BUCK ADJ 300 mA 8LLP	Texas Instruments	LM5018SD/NOPB
82	1	U100	Linear Regulator 3v3 500 mA 6-WSON (2 x 2)	Texas Instruments	TLV75533PDRVR

Table 7: Bill of Materials for Cooling System

Item	Qty	Reference	Part Description	Manufacturer	Part #
1	2	SC1, SC2, SC3, SC4	18-8 Stainless Steel Phillips Flat Head Screw M2 x 0.4 mm Thread, 5 mm Long	McMasterCarr	91698A201
2	4	TIM1	THERM PAD A6200 20 x 20 x 0.5 mm	t-Global	TG-A6200-20-20-0.5
3	1	HS1	Custom heatsink	Alpha Novatech Inc.	LPD2790-35BM-3V6

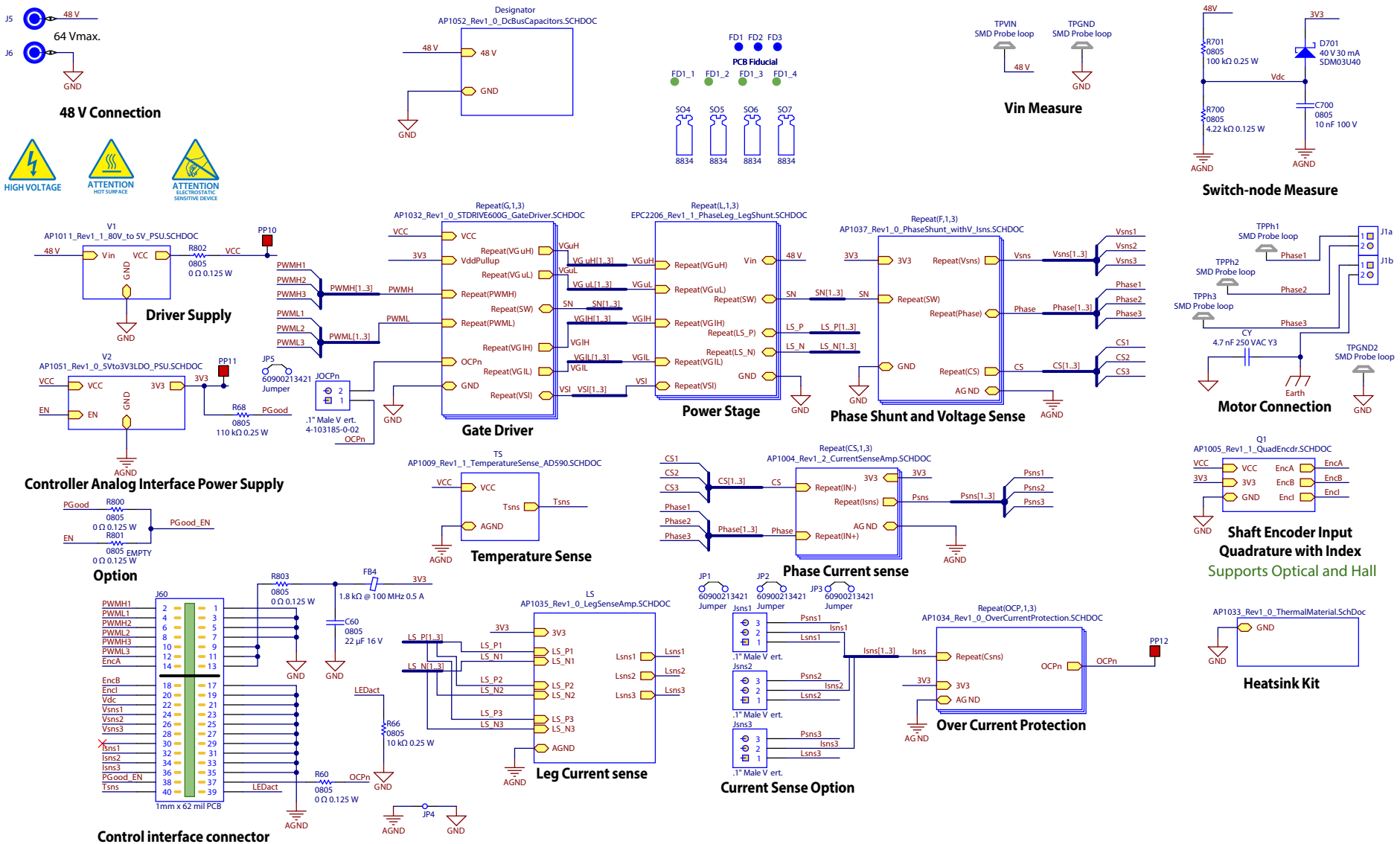

Figure 14 EPC9145 main schematic

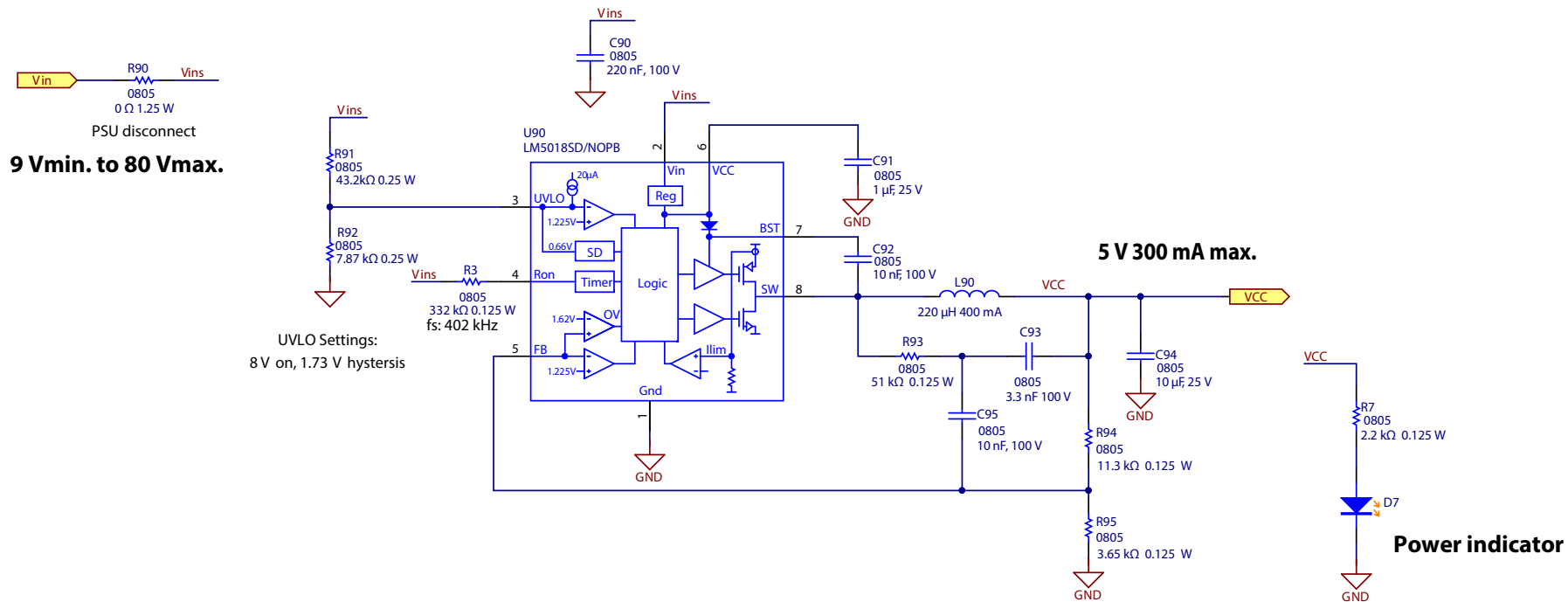
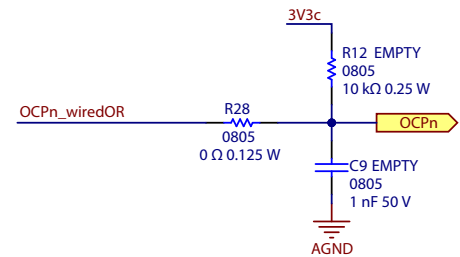
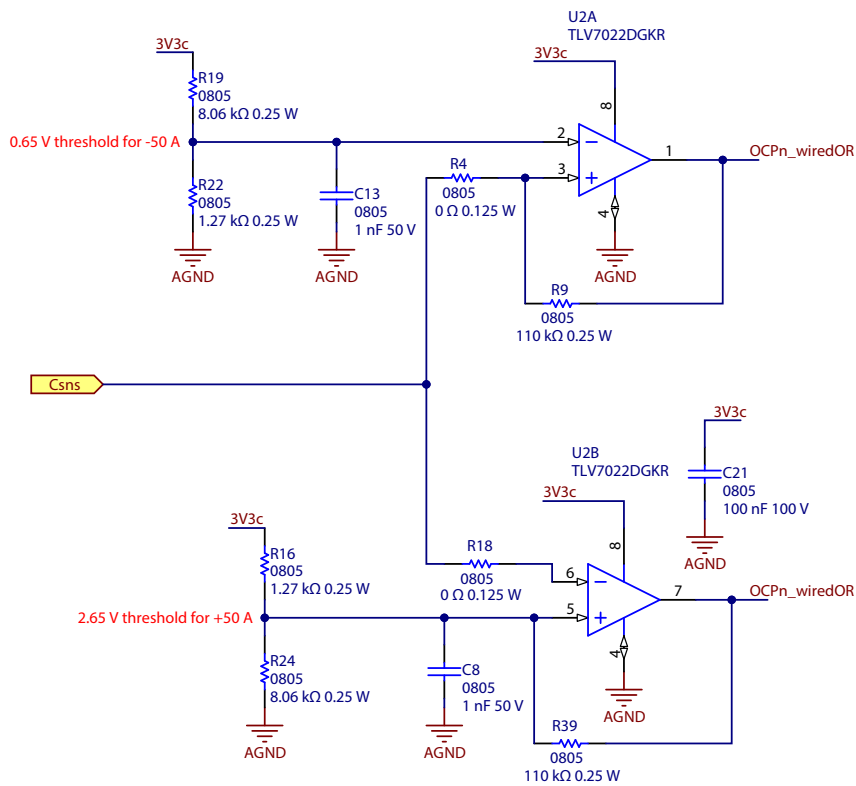
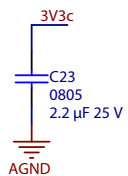

Figure 15: 80 V to 5 V V housekeeping power supply



R12 and C9 are not mounted because they are mounted in front of the gate driver.

Figure 16: Bi-Directional Over Current Detection

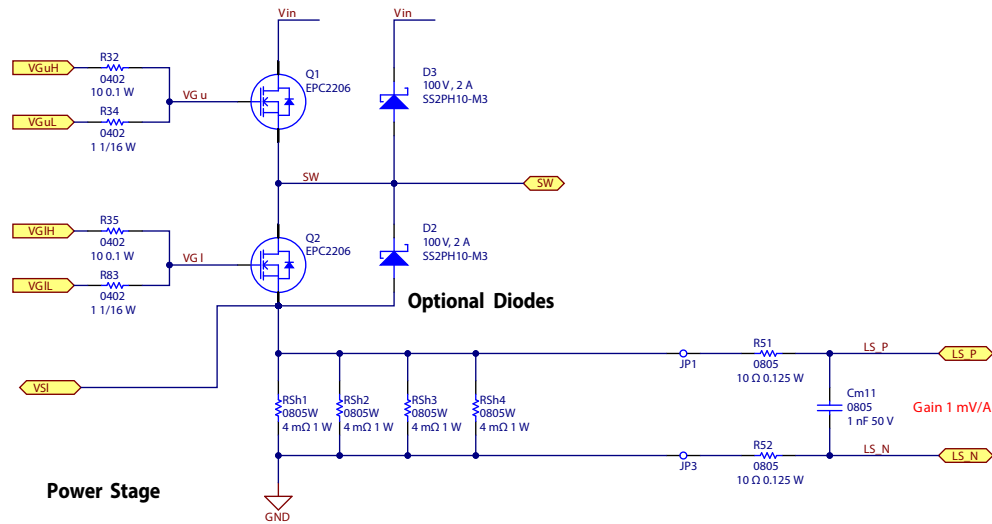
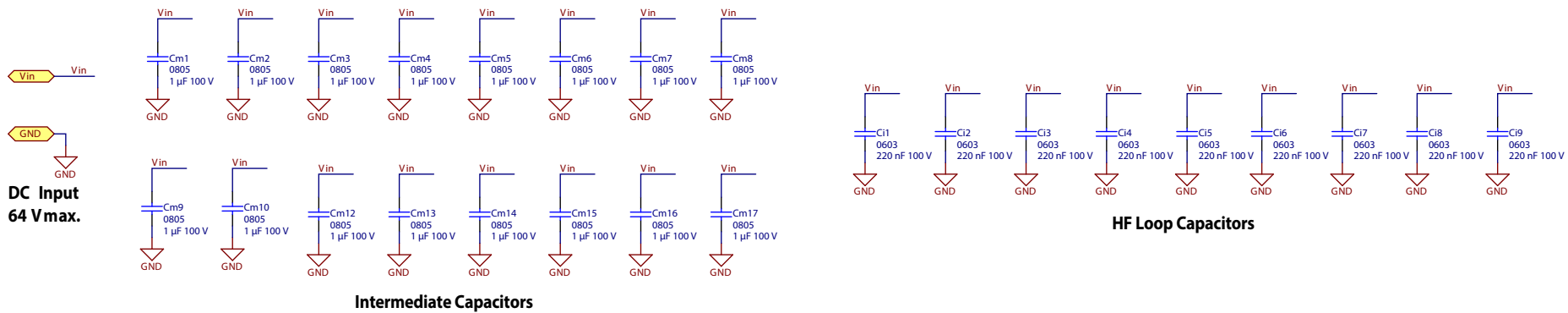

Figure 17: EPC2206 Phase-Leg

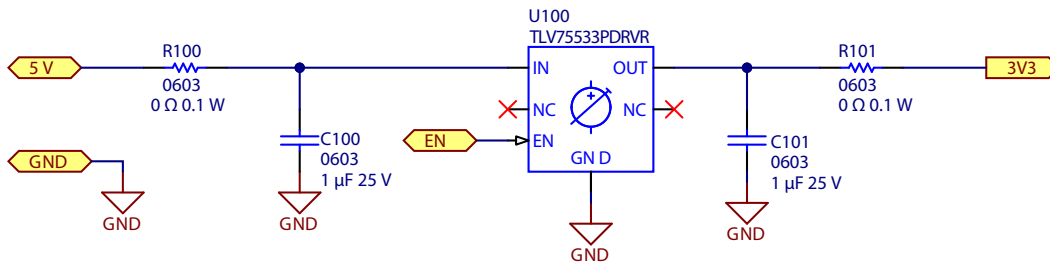

Figure 18: 5 V to 3.3 V LDO power supply

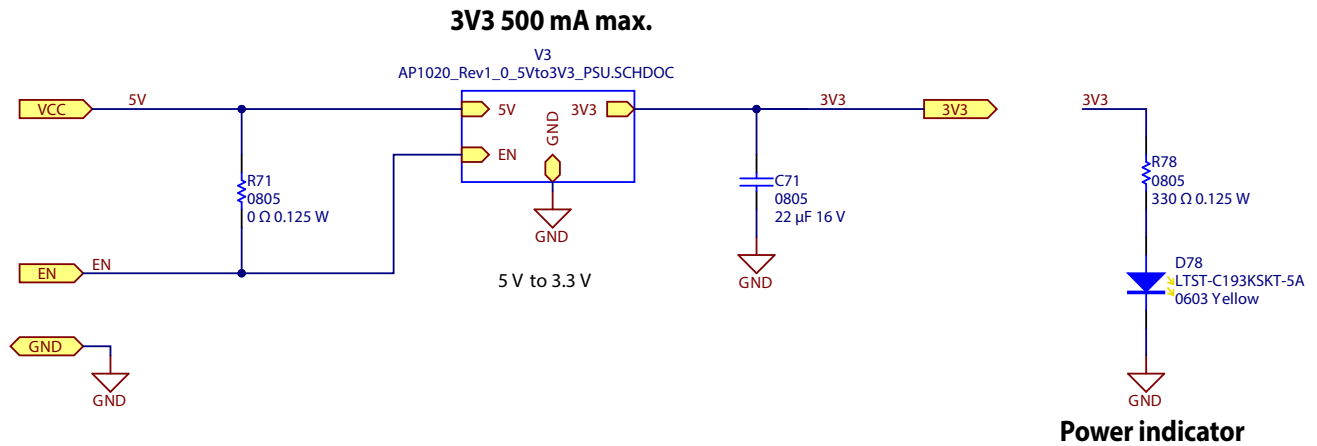

Figure 19: 5 V to 3.3 V LDO Housekeeping Power Supply

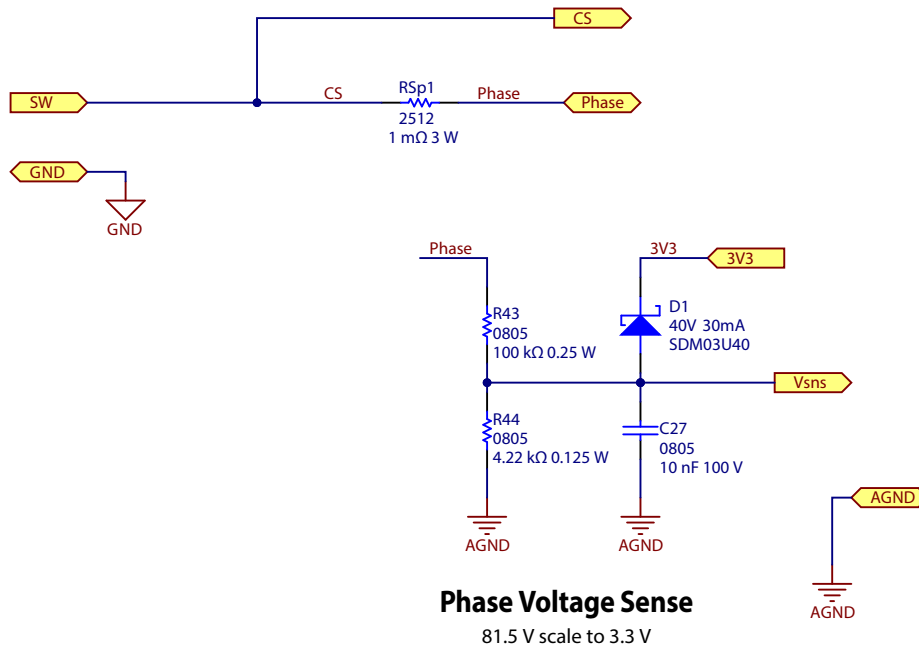
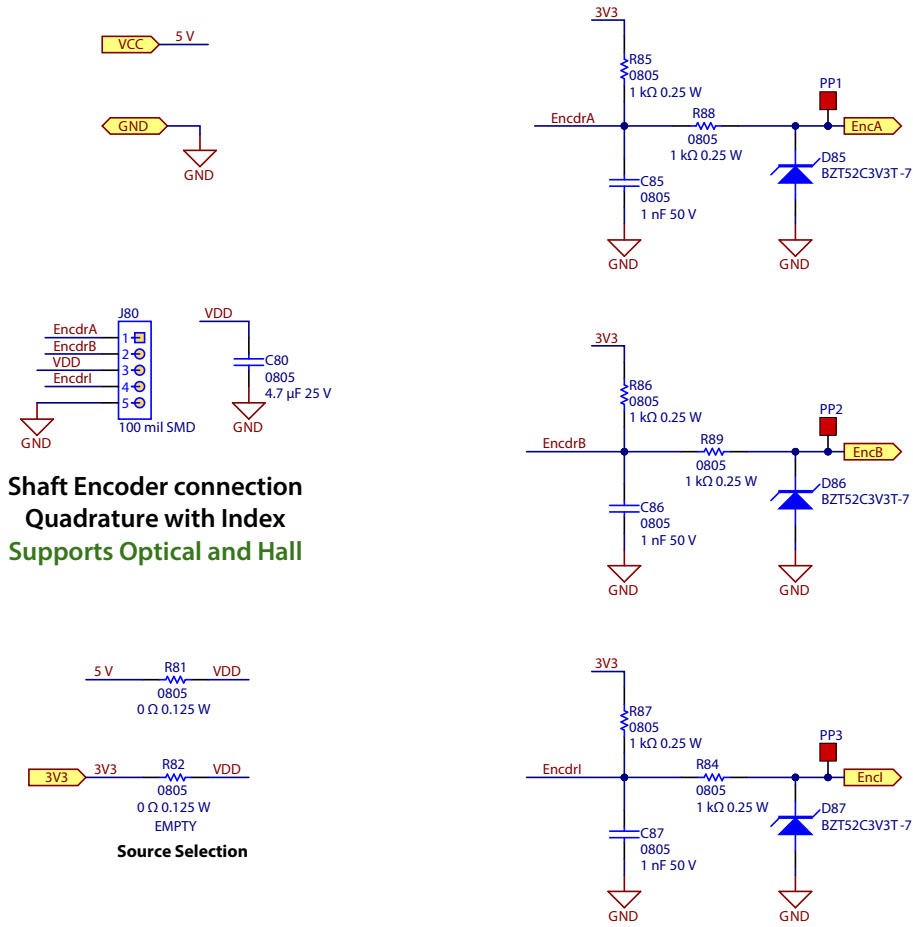

Figure 20: Phase shunt and phase voltage sense



Shaft Encoder connection
Quadrature with Index
Supports Optical and Hall

Figure 21: Shaft-encoder interface schematic

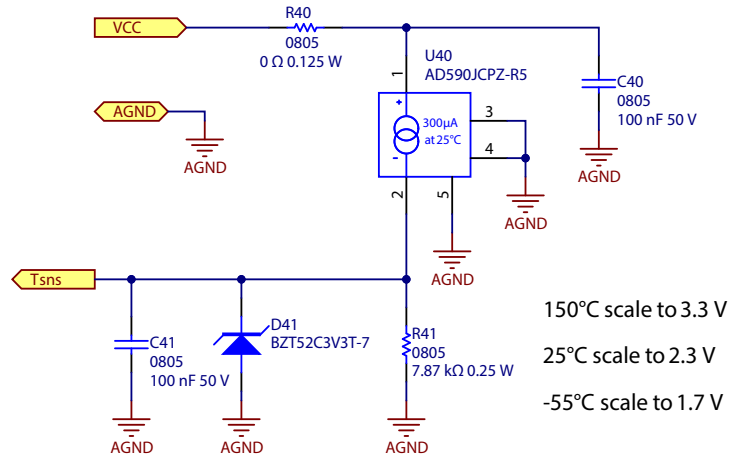

Figure 22: Temperature sensor schematic

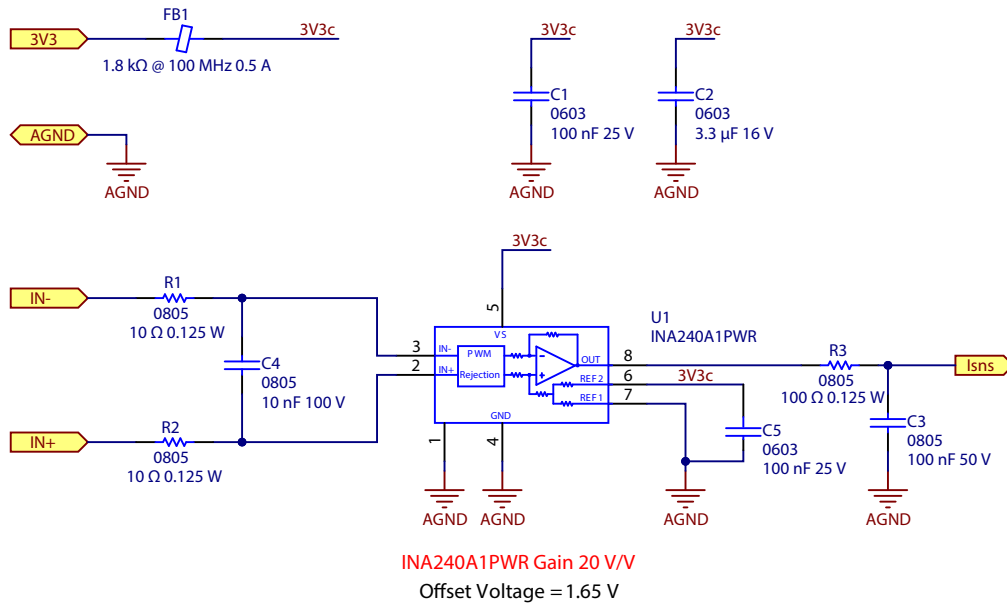

Figure 23: Current sense amplifier

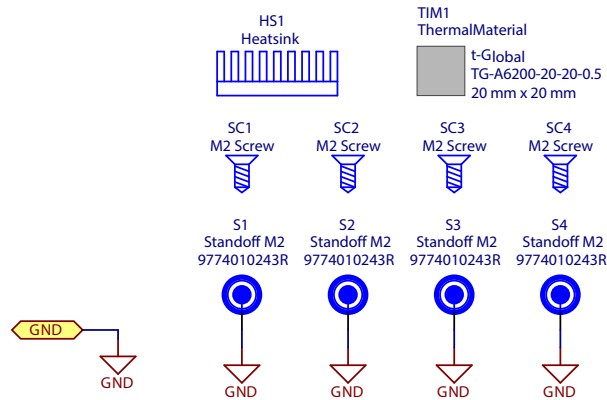

Figure 24: Heatsink kit schematic

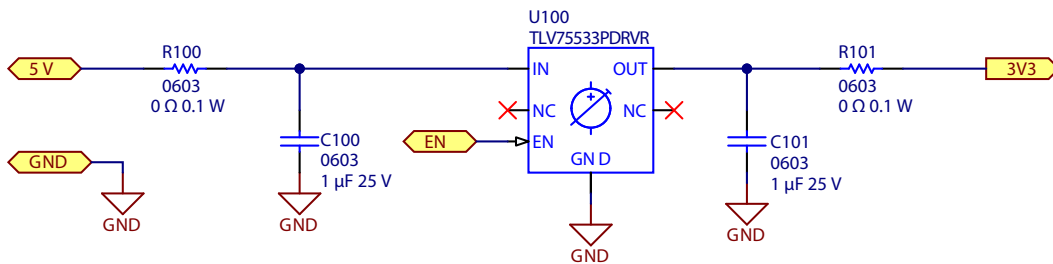
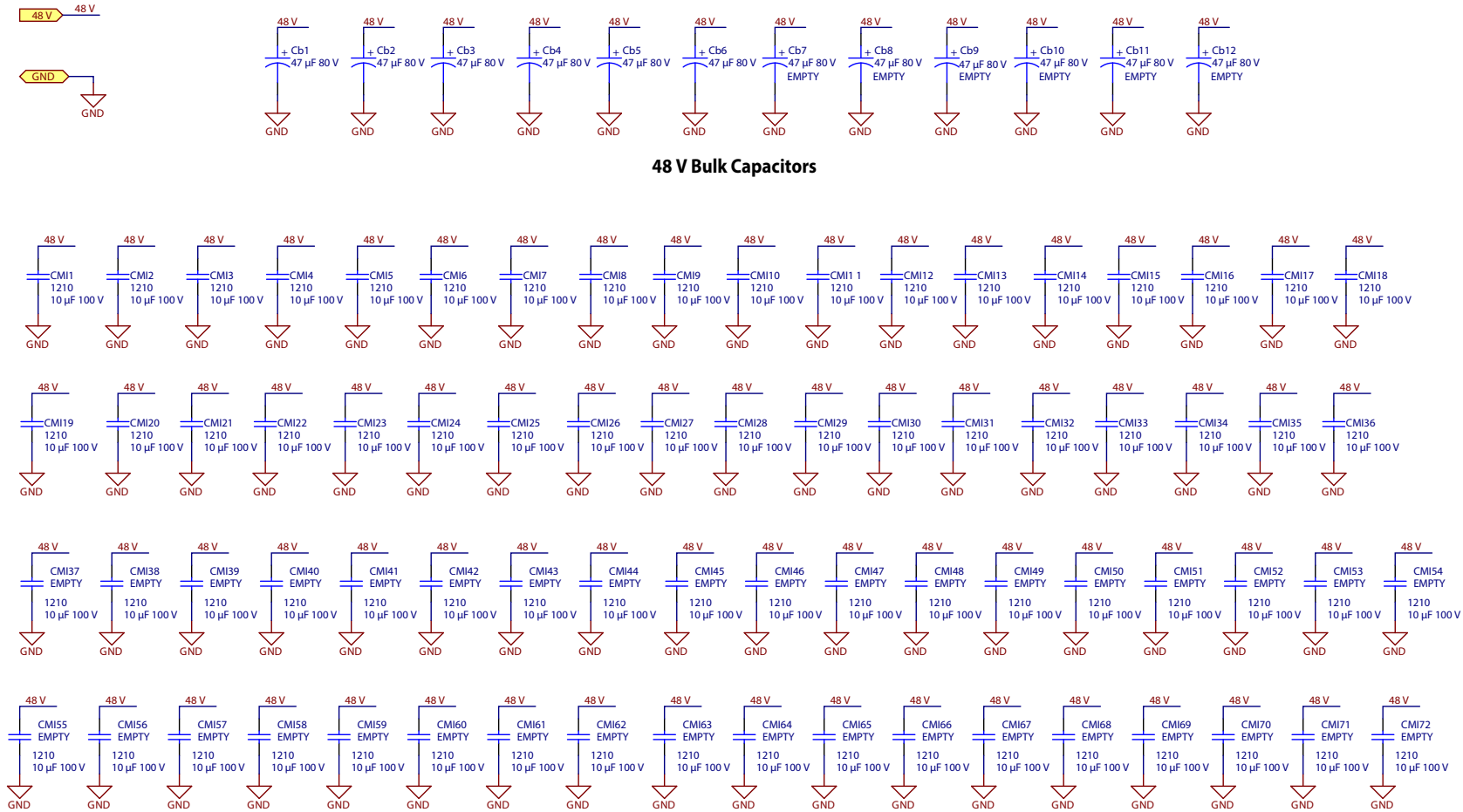

Figure 25: 5 V to 3.3 V LDO power supply schematic



48 V Bulk Capacitors

48 V Medium Frequency Capacitors

Figure 26: High Power Motor Drive DC Bus Capacitors

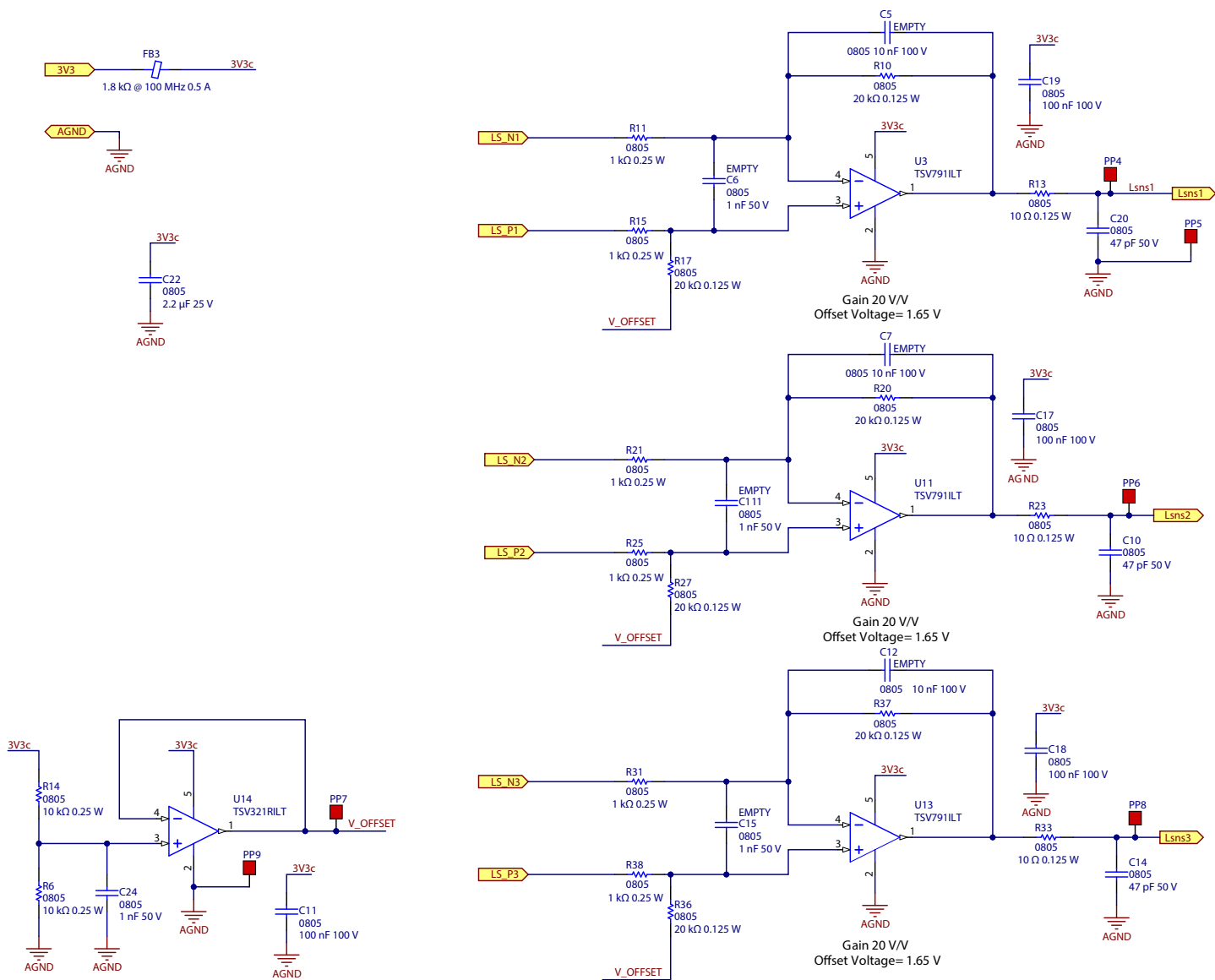

Figure 27: Bi-Directional Leg Current Sense Amplifier

For More Information:

Please contact info@epc-co.com
or your local sales representative

Visit our website:
www.epc-co.com

Sign-up to receive
EPC updates at
bit.ly/EPCupdates
or text "EPC" to 22828



EPC Products are distributed through Digi-Key.
www.digikey.com

Demonstration Board Notification

The EPC9145 board is intended for product evaluation purposes only. It is not intended for commercial use nor is it FCC approved for resale. Replace components on the Evaluation Board only with those parts shown on the parts list (or Bill of Materials) in the Quick Start Guide. Contact an authorized EPC representative with any questions. This board is intended to be used by certified professionals, in a lab environment, following proper safety procedures. Use at your own risk.

As an evaluation tool, this board is not designed for compliance with the European Union directive on electromagnetic compatibility or any other such directives or regulations. As board builds are at times subject to product availability, it is possible that boards may contain components or assembly materials that are not RoHS compliant. Efficient Power Conversion Corporation (EPC) makes no guarantee that the purchased board is 100% RoHS compliant.

The Evaluation board (or kit) is for demonstration purposes only and neither the Board nor this Quick Start Guide constitute a sales contract or create any kind of warranty, whether express or implied, as to the applications or products involved.

Disclaimer: EPC reserves the right at any time, without notice, to make changes to any products described herein to improve reliability, function, or design. EPC does not assume any liability arising out of the application or use of any product or circuit described herein; neither does it convey any license under its patent rights, or other intellectual property whatsoever, nor the rights of others.