



The ET Series of Thermoelectric Modules (TEMs) are designed to operate in high temperature environments.

This product line is available in multiple configurations and is ideal for applications that operate in temperatures above 80°C. Assembled with Bismuth Telluride semiconductor material, thermally conductive Aluminum Oxide ceramics, and high-temperature solder construction, the ET Series is designed for higher current and larger heat-pumping applications.

FEATURES

- High-temperature operation
- Reliable solid state
- No sound or vibration
- Environmentally-friendly
- RoHS-compliant

APPLICATIONS

- Automotive cooling
- Telecom cooling
- Outdoor environments
- Medical heating/cooling

TECHNICAL SPECIFICATIONS

Hot Side Temperature (°C)	85	110
Qmax (W)	21.9	22.5
Delta Tmax (°C)	87	94
I _{max} (Amps)	3.8	3.8
V _{max} (Volts)	10.4	11.3
Module Resistance (Ohms)	2.56	2.84

SUFFIX	THICKNESS (PRIOR TO THINNING)	FLATNESS & PARALLELISM	HOT FACE	COLD FACE	LEAD LENGTH
TA	0.163" ±0.010"	0.001"/0.001"	Lapped	Lapped	6"
TB	0.163" ±0.0005"	0.0005"/0.0005"	Lapped	Lapped	6"

SEALING OPTIONS

SUFFIX	SEALANT	COLOR	TEMPERATURE RANGE	DESCRIPTION
RT	RTV	Clear	-60 to +204 °C	Non-corrosive, silicone adhesive
EP	Epoxy	Black	-55 to +150 °C	Low density syntactic foam epoxy encapsulant

PERFORMANCE CURVES AT $T_h = 85^\circ\text{C}$

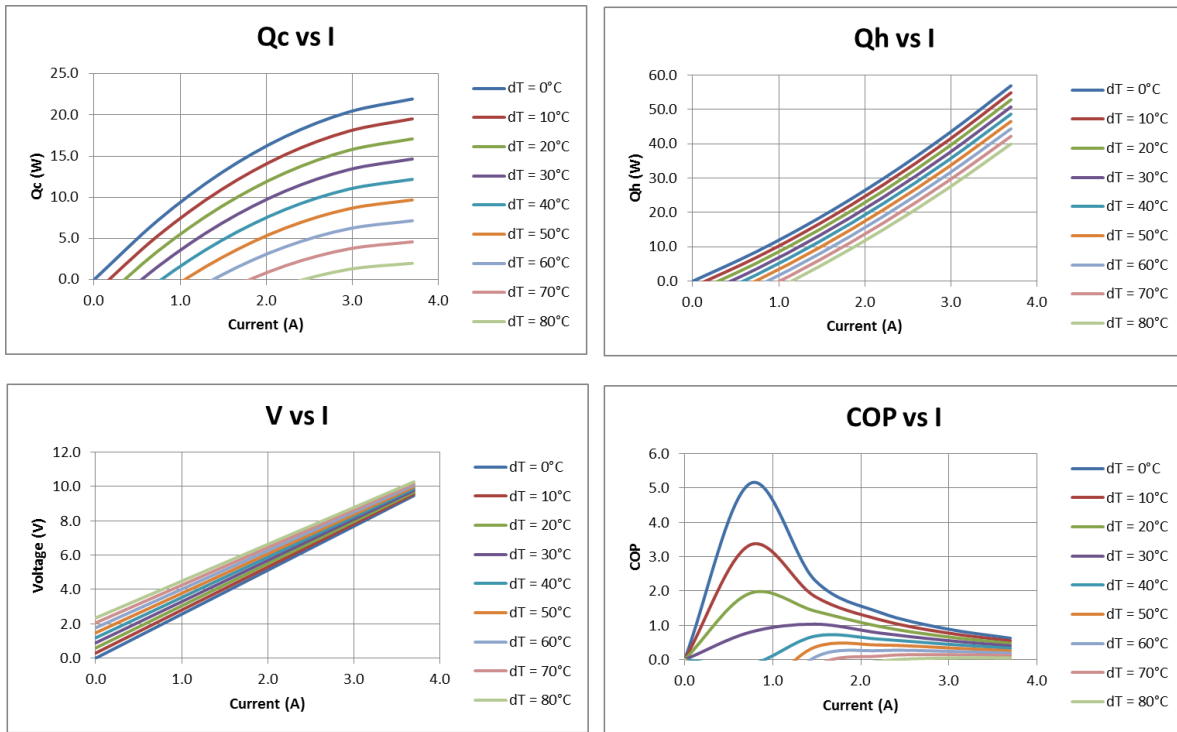

MECHANICAL DRAWING

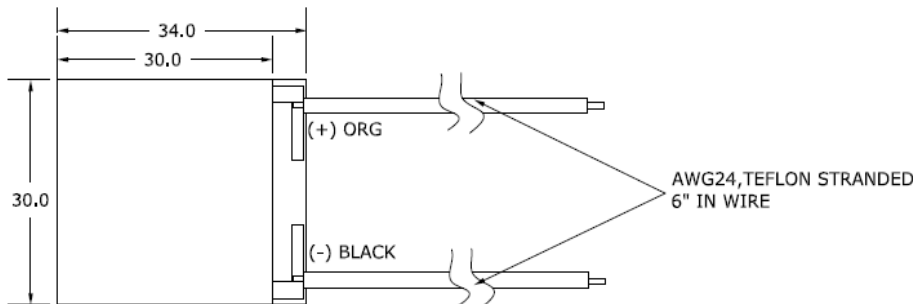

NOTES:

- Maximum Operating Temperature: 150°C
- Do not exceed I_{max} or V_{max} when operating module
- Reference assembly guidelines for recommended installation

COLD SIDE OPTION

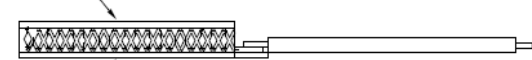

HOT SIDE OPTION

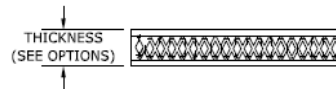

Ceramic Material: Alumina (Al_2O_3)
Solder Construction: 232°C SbSn



Laird warrants to the original end user customer of its products that its products are free from defects in material and workmanship. Subject to conditions and limitations Laird will, at its option, either repair or replace any part of its products that prove defective because of improper workmanship or materials. This limited warranty is in force for the useful lifetime of the original end product into which the Laird product is installed. Useful lifetime of the original end product may vary but is not to exceed five (5) years from the original date of the end product purchase.

Any information furnished by Laird Inc. and its agents is believed to be accurate and reliable. All specifications are subject to change without notice. Responsibility for the use and application of Laird materials rests with the end user, since Laird and its agents cannot be aware of all potential uses. Laird makes no warranties as to the fitness, merchantability or suitability of any Laird materials or products for any specific or general uses. Laird shall not be liable for incidental or consequential damages of any kind. All Laird products are sold pursuant to the Laird Terms and Conditions of sale in effect from time to time, a copy of which will be furnished upon request.

© Copyright 2018 Laird Inc. All Rights Reserved. Laird, Laird Technologies, the Laird Logo, and other marks are trademarks or registered trademarks of Laird Inc. or an affiliate company thereof. Other product or service names may be the property of third parties. Nothing herein provides a license under any Laird or any third party intellectual property rights.

Americas: +1.919.597.7300
Europe: +46.31.420530
Asia: +86.755.2714.1166
ets.sales@lairdtech.com
www.lairdtech.com

