

NOTES:
 ⚠ DATE CODE
 △ DIMENSION A : ILM HEIGHT DEFINE

STATUS	HEIGHT
PER-ASSEMBLY	7.78±0.30
AFTER ASSEMBLY	7.48±0.30

3.THE PARTS 105274**** COMPLIANT TO RoHS DIRECTIVE 2002/95/EC AND ELV 2000/53/EC.

TOP	COMPONENT				
	ITEM NO	Q'TY	PART NO.	DESCRIPTION	MATERIAL
LGA 2011-3 ILM ASSEMBLY (NARROW) PART NO: 105274-1000	1	4	105143-8001	CAPTIVE NUT, SHOULDER(ø6-32 THREAD)	STEEL WITH NICKEL PLATING
	2	1	105275-0001	ILM ACTIVE LEVER	STAINLESS STEEL
	3	4	105143-8003	ILM CAPTIVE NUT COLLAR, SHOULDER	STEEL WITH NICKEL PLATING
	4	1	105275-0002	ILM CLEVIS, ACTIVE	STAINLESS STEEL
	5	1	105275-0003	ILM CLEVIS, HINGE	STAINLESS STEEL
	6	1	105275-0005	ILM FRAME	STEEL WITH NICKEL PLATING
	7	1	105275-0006	ILM FRAME INSULATOR	HALOGEN FREE POLYCARBONATE SHEET
	8	1	105275-0007	ILM HINGE LEVER	STAINLESS STEEL
	9	4	105143-8010	ILM HS STUD (M4 X 0.7MM THREAD)	STEEL WITH NICKEL PLATING
	10	1	105275-0008	ILM LOADPLATE	STAINLESS STEEL
	11	4	105143-8012	ILM RIVET	STAINLESS STEEL
	12	1	105275-0004	ILM COVER	POLYCARBONATE

PROPOSED EC NO: SH2015-0220 DRWN:YXZHENG 2014/10/30 CHKD:AYIN 2015/03/17 APPR:AYIN 2015/03/24	QUALITY SYMBOLS	GENERAL TOLERANCES (UNLESS SPECIFIED)	DIMENSION STYLE MM ONLY	SCALE 1:1	DESIGN UNITS METRIC	THIRD ANGLE PROJECTION
	▽ _A =0	mm INCH	DRAWN BY DATE	TITLE		
	▽ _B =0	4 PLACES ± --- ± ---	YXZHENG 2012/07/25	ILM AND BACK PLATE DRAWING FOR LGA2011-3 SOCKET R3(NARROW)		
	▽ _C =0	3 PLACES ± --- ± ---	CHECKED BY DATE	molex		
▽ _D =0	2 PLACES ± 0.2 ± ---	AYIN 2012/07/25	DOCUMENT NO. SD-105274-001			
	1 PLACE ± 0.3 ± ---	APPROVED BY DATE	SHEET NO. 1 OF 5			
	0 PLACE ± --- ± ---	AYIN 2014/09/02	THIS DRAWING CONTAINS INFORMATION THAT IS PROPRIETARY TO MOLEX INCORPORATED AND SHOULD NOT BE USED WITHOUT WRITTEN PERMISSION			
	ANGULAR ± 3 °	MATERIAL NO.				
	DRAFT WHERE APPLICABLE MUST REMAIN WITHIN DIMENSIONS	SEE TABLE				
		SIZE A3				

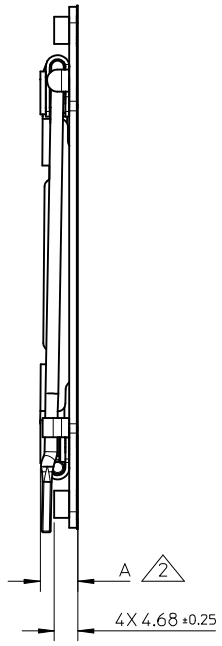
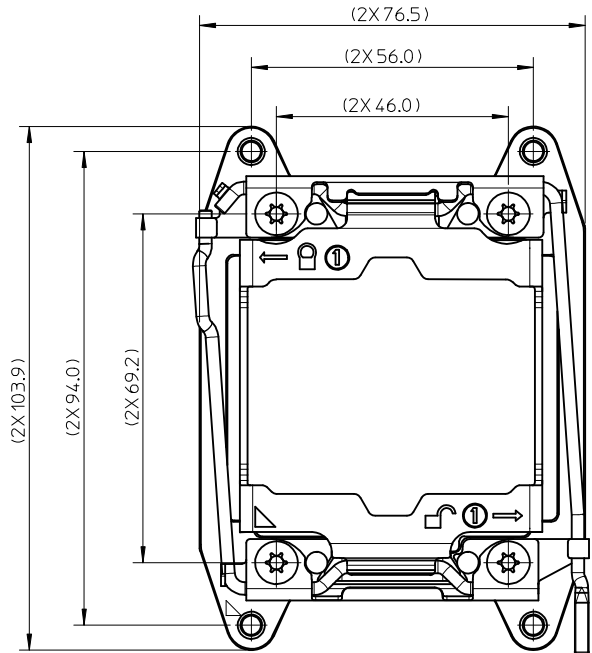

Q'TY	PART NO.	DESCRIPTION
1	105274-1100	LGA2011-3 ILM ASSEMBLY(NARROW) W/O ILM COVER

PROPOSED EC NO: SHZ015-0220 DRWN: YXZHENG CHKD: AYIN APPR: AYIN	2014/10/30 2015/03/17 2015/03/24	DESCRIPTION REV	QUALITY SYMBOLS	GENERAL TOLERANCES (UNLESS SPECIFIED)	DIMENSION STYLE	SCALE	DESIGN UNITS	THIRD ANGLE PROJECTION	
			$F_A = 0$ $F_G = 0$ $F_P = 0$	mm INCH 4 PLACES ± --- ± --- 3 PLACES ± --- ± --- 2 PLACES ± 0.2 ± --- 1 PLACE ± 0.3 ± --- 0 PLACE ± --- ± ---	MM ONLY	1:1	METRIC	DRAWN BY: YXZHENG DATE: 2012/07/25 CHECKED BY: AYIN DATE: 2012/07/25 APPROVED BY: AYIN DATE: 2014/09/02	TITLE ILM AND BACK PLATE DRAWING FOR LGA2011-3 SOCKET R3(NARROW)
			ANGULAR ± 3 ° DRAFT WHERE APPLICABLE MUST REMAIN WITHIN DIMENSIONS	SEE TABLE	MATERIAL NO.	DOCUMENT NO.	SHEET NO.		
							2 OF 5		



THIS DRAWING CONTAINS INFORMATION THAT IS PROPRIETARY TO MOLEX INCORPORATED AND SHOULD NOT BE USED WITHOUT WRITTEN PERMISSION

LGA2011-3 ILM ASSEMBLY
PART NO.:1052741000

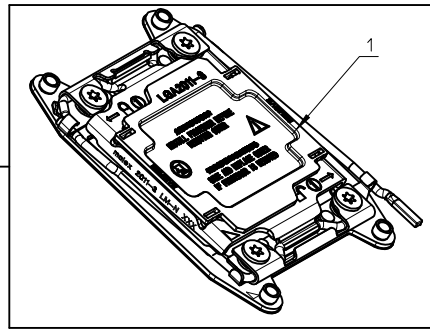

LGA2011-3 ILM ASSEMBLY
AND BACK PLATE
PART NO.:1052741200

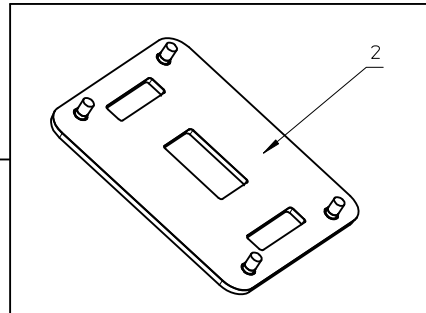
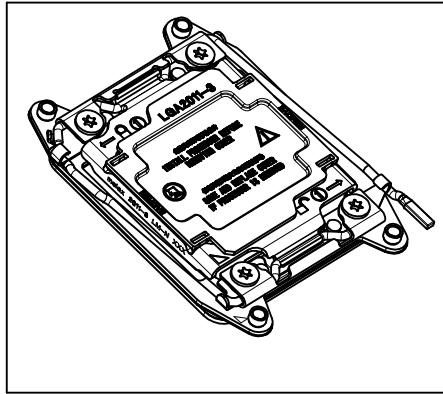

LGA2011-3 BACK PLATE
PART NO.:1051427003

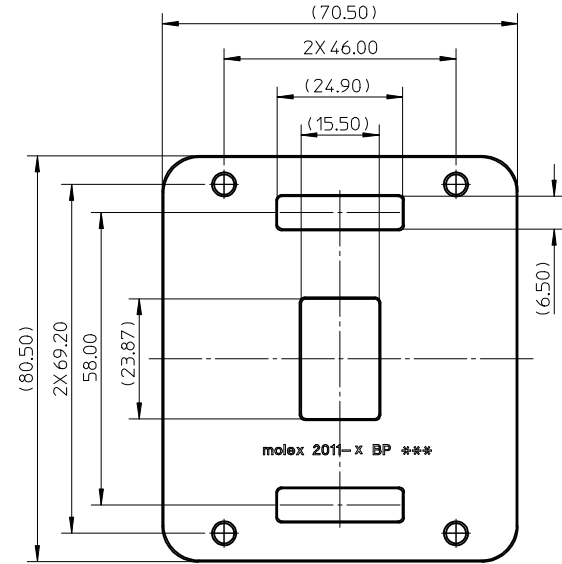

Q'TY	ITEM	PART NO.	DESCRIPTION
1	TOP	105274-1200	LGA2011-3 ILM (NARROW) AND BACK PLATE
1	1	1052741000	LGA2011-3 ILM (NARROW)
1	2	1051427003	LGA2011-3 ILM BACK PLATE

ENTER DESCRIPTION	REV	DESCRIPTION	QUALITY SYMBOLS	GENERAL TOLERANCES (UNLESS SPECIFIED)		DIMENSION STYLE	SCALE	DESIGN UNITS	THIRD ANGLE PROJECTION
				mm	INCH	MM ONLY	1:1	METRIC	
EC NO: SHZ015-0220	2	DESCRIPTION	$\nabla_A=0$	4 PLACES	\pm ---	DRAWN BY	DATE	TITLE	ILM AND BACK PLATE DRAWING FOR LGA2011-3 SOCKET R3(NARROW) molex SD-105274-001 SHEET NO. 3 OF 5
DRWN:YXZHENG			$\nabla_C=0$	3 PLACES	\pm ---	CHECKED BY	DATE		
CHKD:AYIN			$\nabla_B=0$	2 PLACES	± 0.2	AYIN	2012/07/25		
APPR:AYIN			$\nabla_P=0$	1 PLACE	± 0.3	APPROVED BY	DATE		
				0 PLACE	\pm ---	AYIN	2014/09/02		
				ANGULAR $\pm 3^\circ$		MATERIAL NO.	DOCUMENT NO.		SHEET NO.
				DRAFT WHERE APPLICABLE MUST REMAIN WITHIN DIMENSIONS		SEE TABLE		SD-105274-001	
						THIS DRAWING CONTAINS INFORMATION THAT IS PROPRIETARY TO MOLEX INCORPORATED AND SHOULD NOT BE USED WITHOUT WRITTEN PERMISSION			

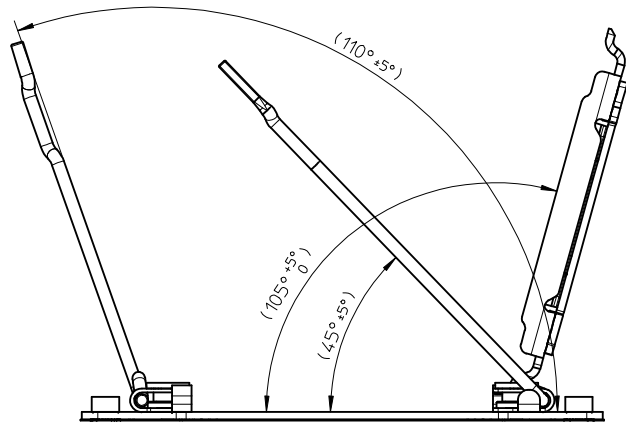

ILM OPEN ANGLE REFERENCE ONLY

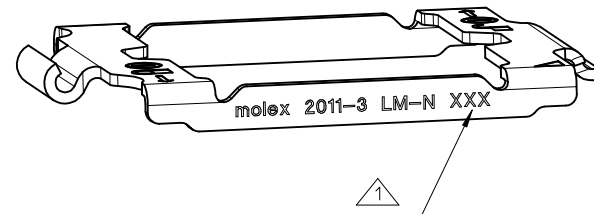

PROPOSED EC NO: SHZ015-0220 DRWN: YXZHENG CHKD: AYIN APPR: AYIN	2014/10/30 2015/03/17 2015/03/24	DESCRIPTION REV	QUALITY SYMBOLS	GENERAL TOLERANCES (UNLESS SPECIFIED)		DIMENSION STYLE MM ONLY		SCALE 1:1	DESIGN UNITS METRIC	THIRD ANGLE PROJECTION													
			$F_A = 0$ $F_G = 0$ $F_P = 0$	<table border="1"> <thead> <tr> <th></th> <th>mm</th> <th>INCH</th> </tr> </thead> <tbody> <tr> <td>4 PLACES</td> <td>± ---</td> <td>± ---</td> </tr> <tr> <td>3 PLACES</td> <td>± ---</td> <td>± ---</td> </tr> <tr> <td>2 PLACES</td> <td>± 0.2</td> <td>± ---</td> </tr> <tr> <td>1 PLACE</td> <td>± 0.3</td> <td>± ---</td> </tr> <tr> <td>0 PLACE</td> <td>± ---</td> <td>± ---</td> </tr> </tbody> </table>		mm	INCH	4 PLACES	± ---	± ---	3 PLACES	± ---	± ---	2 PLACES	± 0.2	± ---	1 PLACE	± 0.3	± ---	0 PLACE	± ---	± ---	mm INCH DRAWN BY: YXZHENG DATE: 2012/07/25 CHECKED BY: AYIN DATE: 2012/07/25 APPROVED BY: AYIN DATE: 2014/09/02
	mm	INCH																					
4 PLACES	± ---	± ---																					
3 PLACES	± ---	± ---																					
2 PLACES	± 0.2	± ---																					
1 PLACE	± 0.3	± ---																					
0 PLACE	± ---	± ---																					
DRAFT WHERE APPLICABLE MUST REMAIN WITHIN DIMENSIONS			ANGULAR ± 3 °		MATERIAL NO. SEE TABLE		DOCUMENT NO. SD-105274-001	SHEET NO. 4 OF 5															
THIS DRAWING CONTAINS INFORMATION THAT IS PROPRIETARY TO MOLEX INCORPORATED AND SHOULD NOT BE USED WITHOUT WRITTEN PERMISSION																							

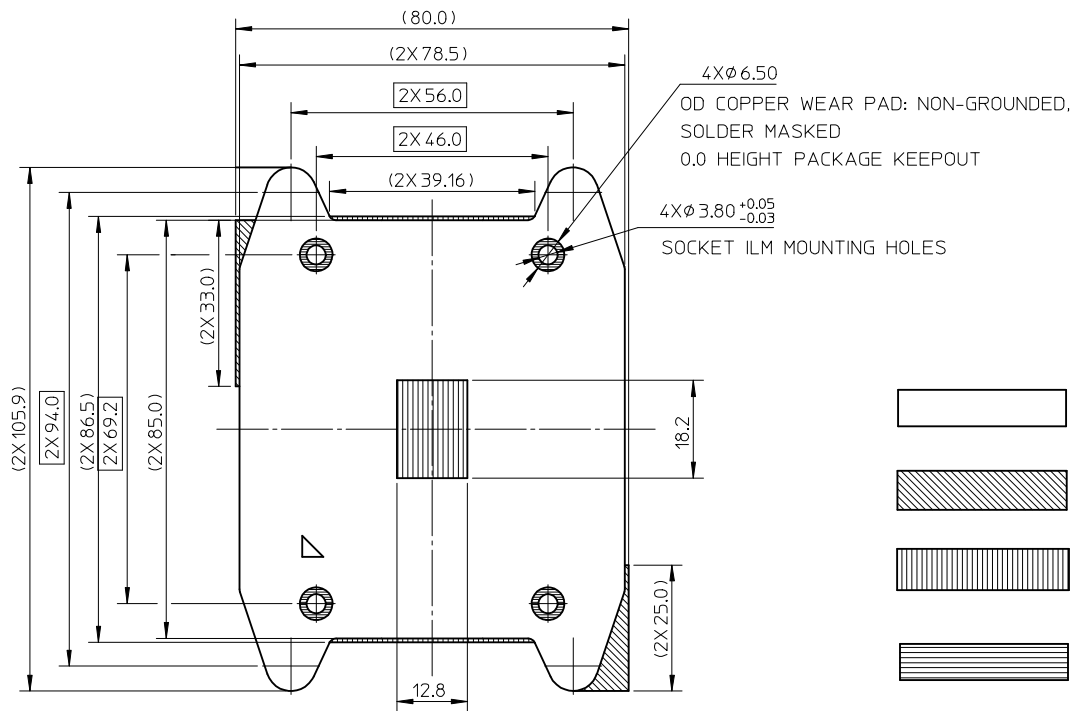

- ZONE 1:
0.0 MM MAX COMPONENT HEIGHT, NO COMPONENT PLACEMENT, SOCKET, ILM, AND FINGER ACCESS KEEPIN ZONE
- ZONE 2:
1.40MM MAX COMPONENT HEIGHT
- ZONE 3:
1.60MM MAX COMPONENT HEIGHT
- ZONE 4:
0.0 MM MAX COMPONENT HEIGHT, NO COMPONENT PLACEMENT

NOTES:

1. MAXIMUM OUTLINE OF SOCKET MUST BE PLACED SYMMETRIC TO THE ILM HOLE PATTERN FOR PROPER ILM AND SOCKET FUNCTION.
2. A HEIGHT RESTRICTION ZONE IS DEFINED AS ONE WHERE ALL COMPONENTS PLACED ON THE SURFACE OF THE MOTHERBOARD MUST HAVE A MAXIMUM HEIGHT NO GREATER THAN THE HEIGHT DEFINED BY THAT ZONE.
3. UNLESS OTHERWISE NOTED ALL VIEW DIMENSION ARE NOMINAL. ALL HEIGHT RESTRICTIONS ARE MAXIMUMS. NEITHER ARE DRIVEN BY IMPLIED TOLERANCES.
4. A HEIGHT RESTRICTION OF 0.0 MM REPRESENTS THE TOP (OR BOTTOM) SURFACE OF THE MOTHERBOARD AS THE MAXIMUM HEIGHT. THIS IS A NO COMPONENT PLACEMENT ZONE INCLUDING SOLDER BUMPS. SEE NOTE 5 FOR ADDITIONAL DETAILS.
5. ASSUMING A GENERIC A MAXIMUM COMPONENT HEIGHT ZONE. CHOICE OF AND COMPONENT PLACEMENT IN THIS ZONE MUST INCLUDE:
 - COMPONENT NOMINAL HEIGHT
 - COMPONENT TOLERANCES
 - COMPONENT PLACEMENT TILT
 - SOLDER REFLOW THICKNESS
 DO NOT PLACE COMPONENTS IN THIS ZONE THAT WILL EXCEED THIS MAXIMUM COMPONENT HEIGHT

PROPOSED EC NO: SH2015-0220 DRWN: YXZHENG CHKD: AYIN APPR: AYIN	2014/10/30 2015/03/17 2015/03/24	DESCRIPTION QUALITY SYMBOLS $F_A=0$ $F_G=0$ $F_P=0$	GENERAL TOLERANCES (UNLESS SPECIFIED)		DIMENSION STYLE	SCALE	DESIGN UNITS	THIRD ANGLE PROJECTION		
					MM ONLY	1:1	METRIC			
					DRAWN BY	DATE	TITLE			
					CHECKED BY	DATE	ILM AND BACK PLATE DRAWING FOR LGA2011-3 SOCKET R3(NARROW)			
				APPROVED BY	DATE	molex SD-105274-001				
				AYIN	2014/09/02					
				MATERIAL NO.		DOCUMENT NO.				
				SEE TABLE		SD-105274-001				
				DRAFT WHERE APPLICABLE MUST REMAIN WITHIN DIMENSIONS		SHEET NO. 5 OF 5				
				SIZE A3		THIS DRAWING CONTAINS INFORMATION THAT IS PROPRIETARY TO MOLEX INCORPORATED AND SHOULD NOT BE USED WITHOUT WRITTEN PERMISSION				