

REVISION HISTORY				
ZONE	REV	DESCRIPTION	DATE	BY
ALL	NC	ENGINEERING RELEASE	4/18/2014	EAS

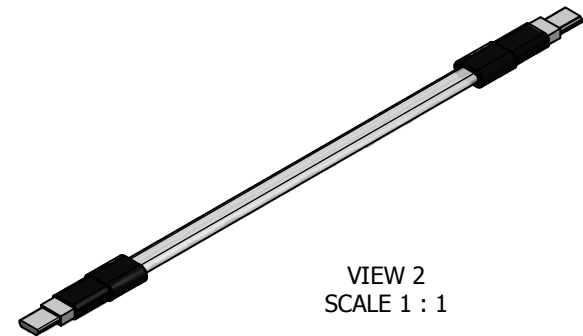
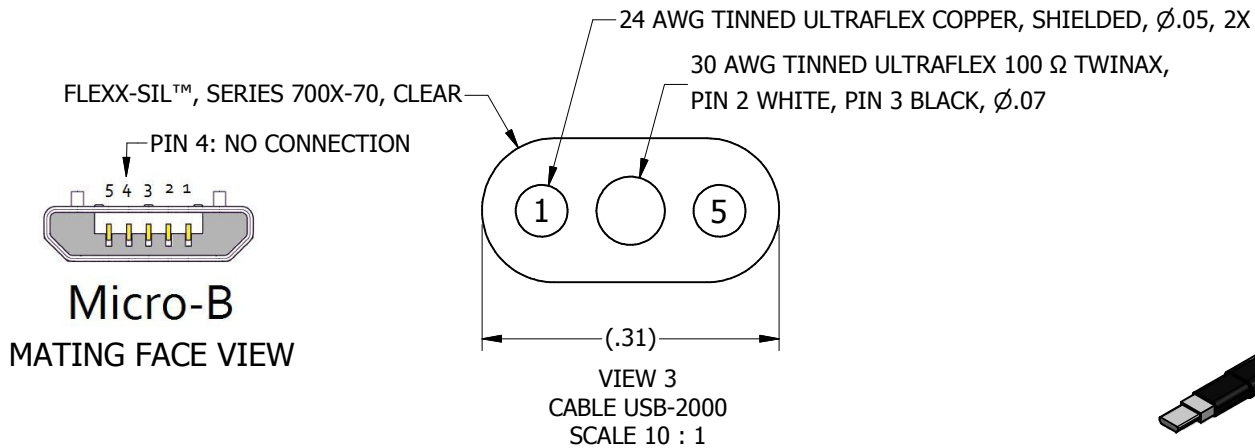
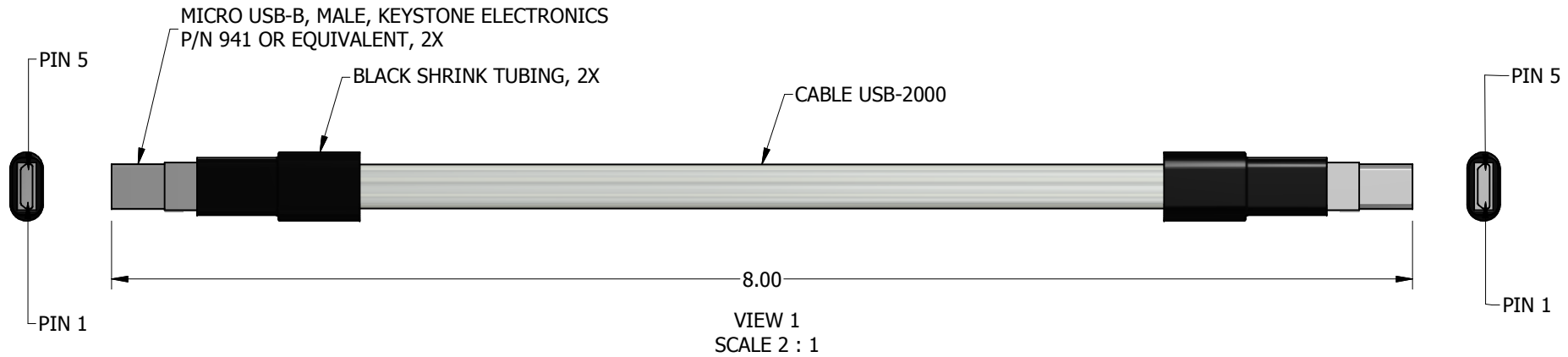

Micro-B
MATING FACE VIEW

NOTES: UNLESS OTHERWISE SPECIFIED:
1.

<small>THESE DRAWINGS AND SPECIFICATIONS ARE THE PROPERTY OF CICCOIL LLC AND ARE ISSUED IN STRICT CONFIDENCE AND SHALL NOT BE REPRODUCED OR COPIED OR USED AS THE BASIS FOR THE MANUFACTURE OR SALE OF EQUIPMENT WITHOUT PERMISSION.</small>				VIEW PROJECTION		CICOIL The Clear Choice 24960 AVENUE TIBBITTS, VALENCIA, CA 91355 www.ciccoil.com 661-295-1295			
				STANDARD TOLERANCES UNLESS OTHERWISE NOTED	SIGNATURE				DATE
			DRAWN:	EAS	5/16/2014	TITLE MICRO USB-B CABLE ASSEMBLY			
			CHECK:	EAS	6/18/2014				
			ENGINEER:	EAS	6/18/2014				
			CUSTOMER:	CHRISTOPHER VOSS	6/18/2014				
DASH NO	QTY REQD	NEXT ASSEMBLY	FINAL ASSEMBLY	MATERIAL:		CAGE CODE	SIZE	DRAWING NUMBER	REVISION
				APPLICATION		19476		879R101	NC
CAE SANTÉ / CAE HEALTHCARE				DO NOT SCALE DRAWING		SCALE	FILE: 879R101NC.idw		SHEET 1 OF 1