

Customer Information Sheet

DRAWING No.: G125-MHX0805M3-IADIADP

IF IN DOUBT - ASK

©

NOT TO SCALE

THIRD ANGLE PROJECTION

ALL DIMENSIONS IN mm

ASSEMBLY P/No.	DIM 'A'
G125-MHX0805M3-IADIADP	3.3±0.15

ORDER CODE:
G125-MHX0805M3-IADIADP
 3.30mm PC-TAILS = HI

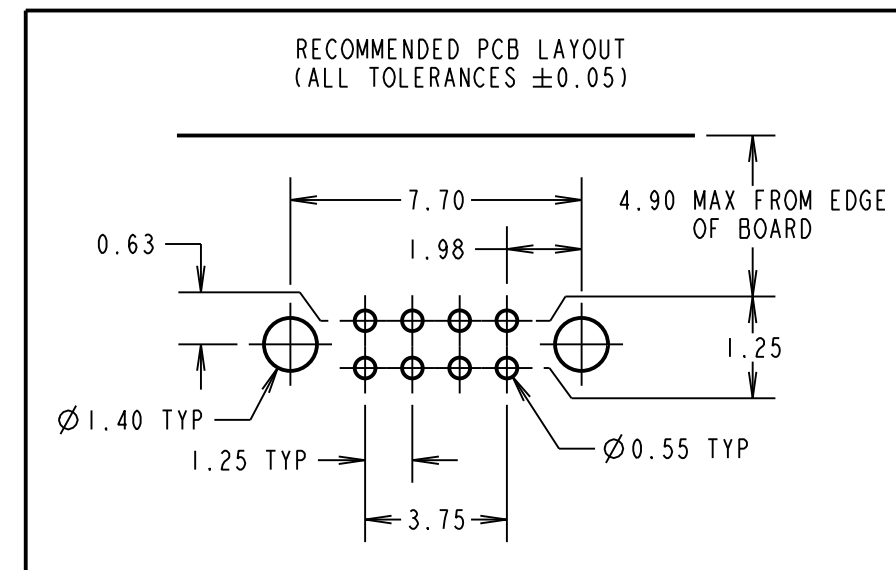
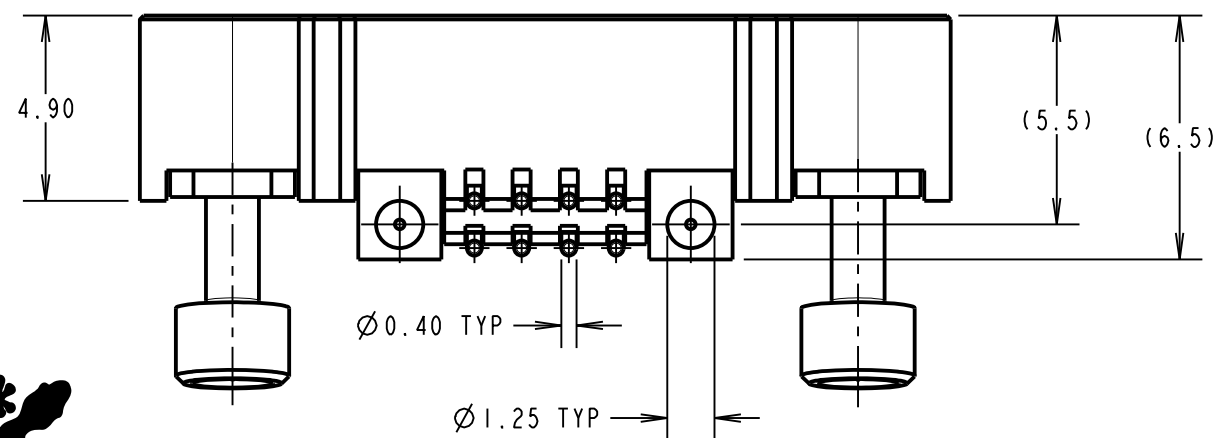
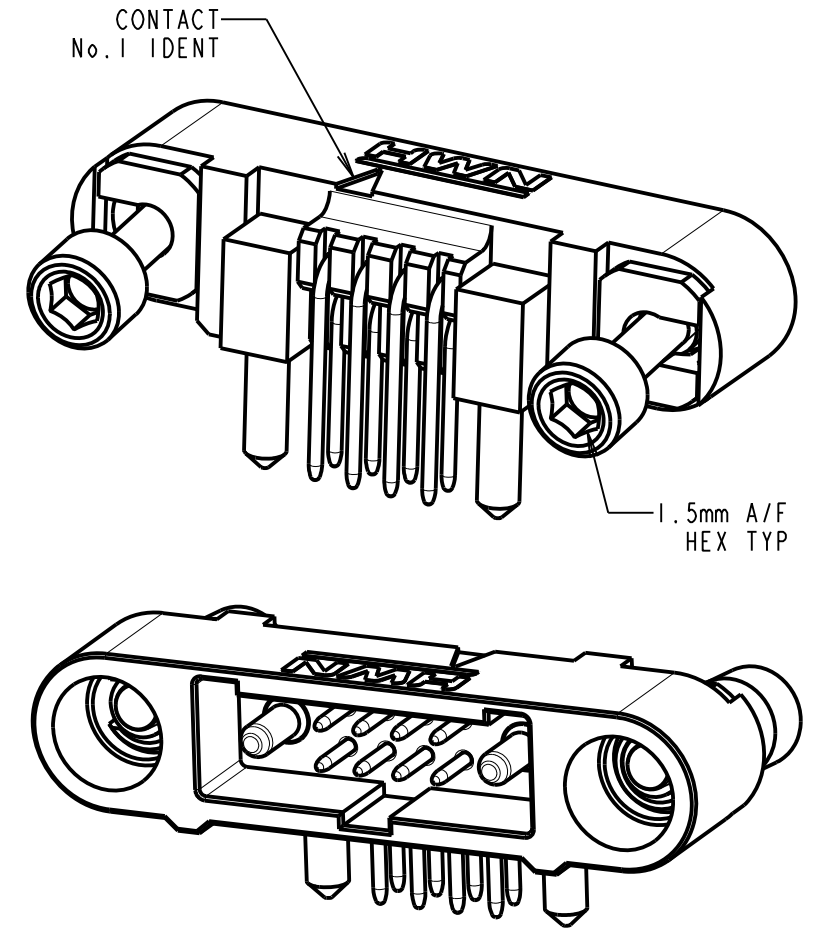
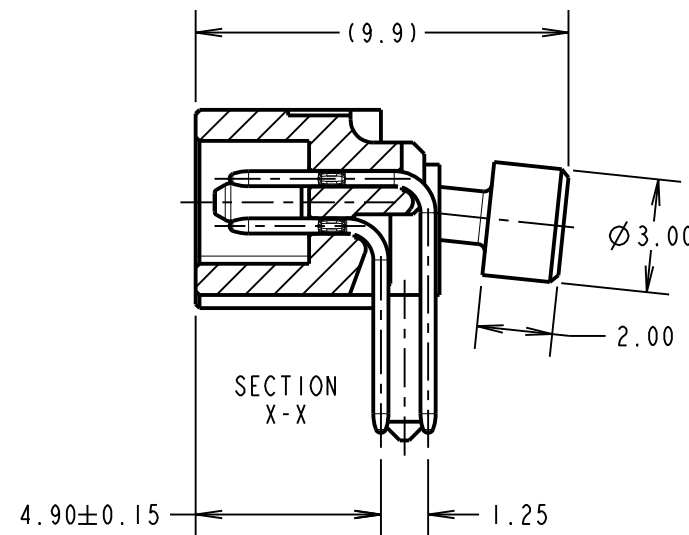
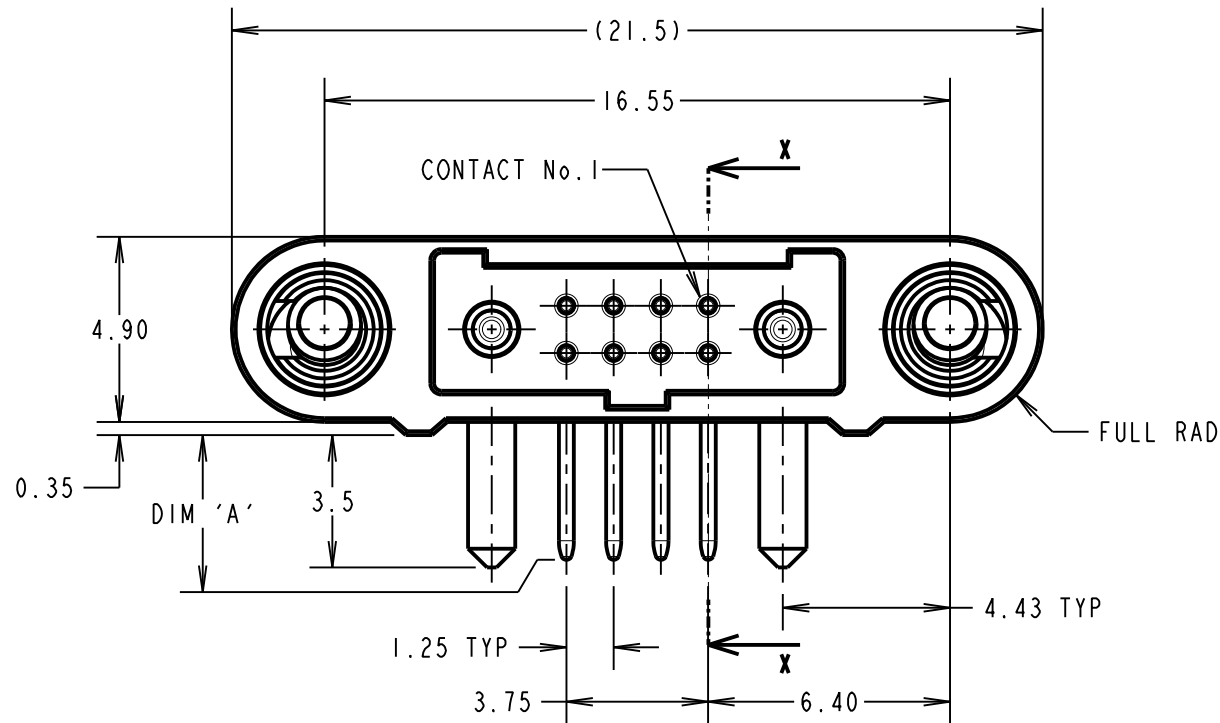

CONNECTOR AND PCB LAYOUT DETAILS ONLY
 SEE SHEET 4 FOR TAPE STRIP DETAILS

NOTES:
 1. FOR MATERIALS, FINISH AND SPECIFICATIONS SEE GECKO SERIES SPECIFICATION SUMMARY SHEET OR COMPONENT SPECIFICATION C125XX (LATEST ISSUE) FOR FULL SPECIFICATION.

MR	2	27.02.20	30006
NAME	ISS.	DATE	C/NOTE
APPROVED: M. RUDKIN			
CHECKED: R. PORTLOCK			
DRAWN: MARK G PLESTED			
CUSTOMER REF.:			
ASSEMBLY DRG:			



HARWIN

www.harwin.com
 technical@harwin.com

THIS DRAWING AND ANY INFORMATION OR DESCRIPTIVE MATTER SET OUT HEREON ARE CONFIDENTIAL AND COPYRIGHT PROPERTY OF THE HARWIN GROUP AND MUST NOT BE DISCLOSED, LOANED, COPIED OR USED FOR MANUFACTURING, TENDERING OR FOR ANY OTHER PURPOSE WITHOUT THEIR WRITTEN PERMISSION.

TOLERANCES
 X. = ±1mm
 X.X = ±0.50mm
 X.XX = ±0.20mm
 X.XXX = ±0.01mm
 ANGLES = ±5°
 UNLESS STATED

MATERIAL:
 SEE ABOVE
 FINISH: SEE ABOVE
 S/AREA: mm²

TITLE:
 G125 MT SERIES MALE
 HORIZONTAL PC TAIL CONNECTOR
 DRAWING NUMBER:
G125-MHX0805M3-IADIADP 3 OF 4

Customer Information Sheet

DRAWING No.: G125-MHX0805M3-IADIADP

IF IN DOUBT - ASK

©

NOT TO SCALE

THIRD ANGLE PROJECTION

ALL DIMENSIONS IN mm

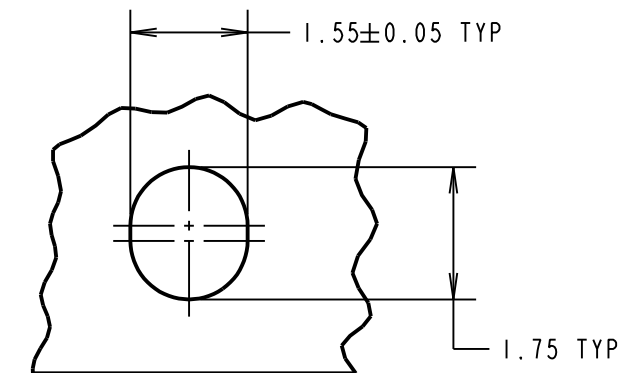
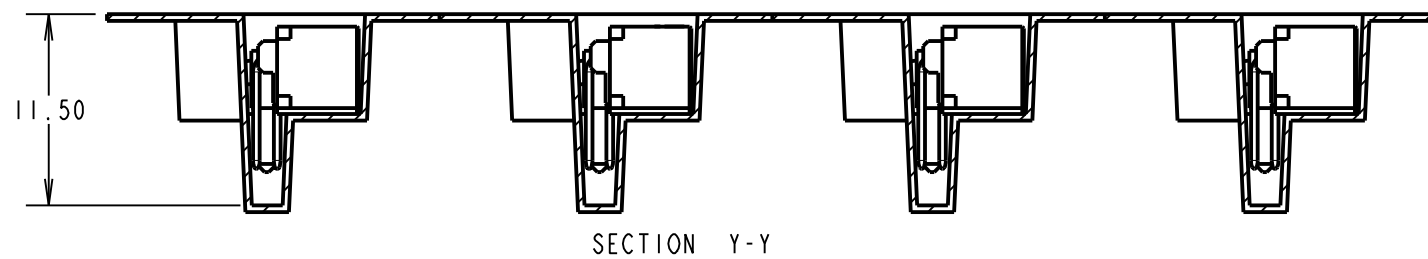
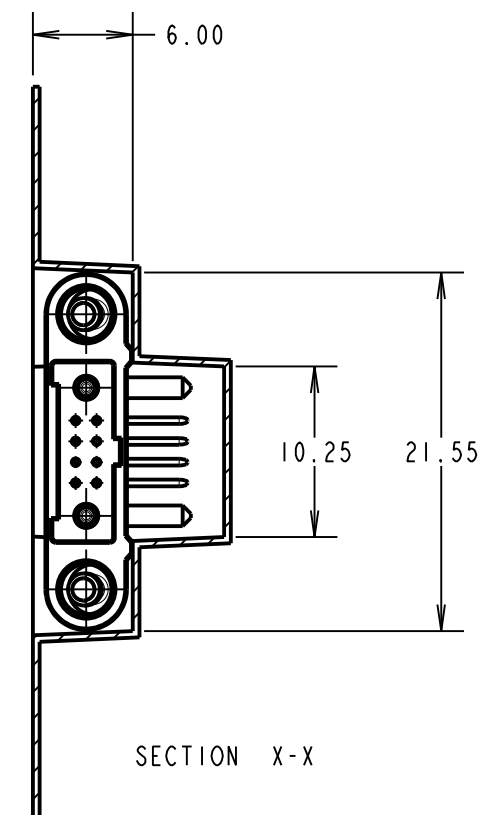
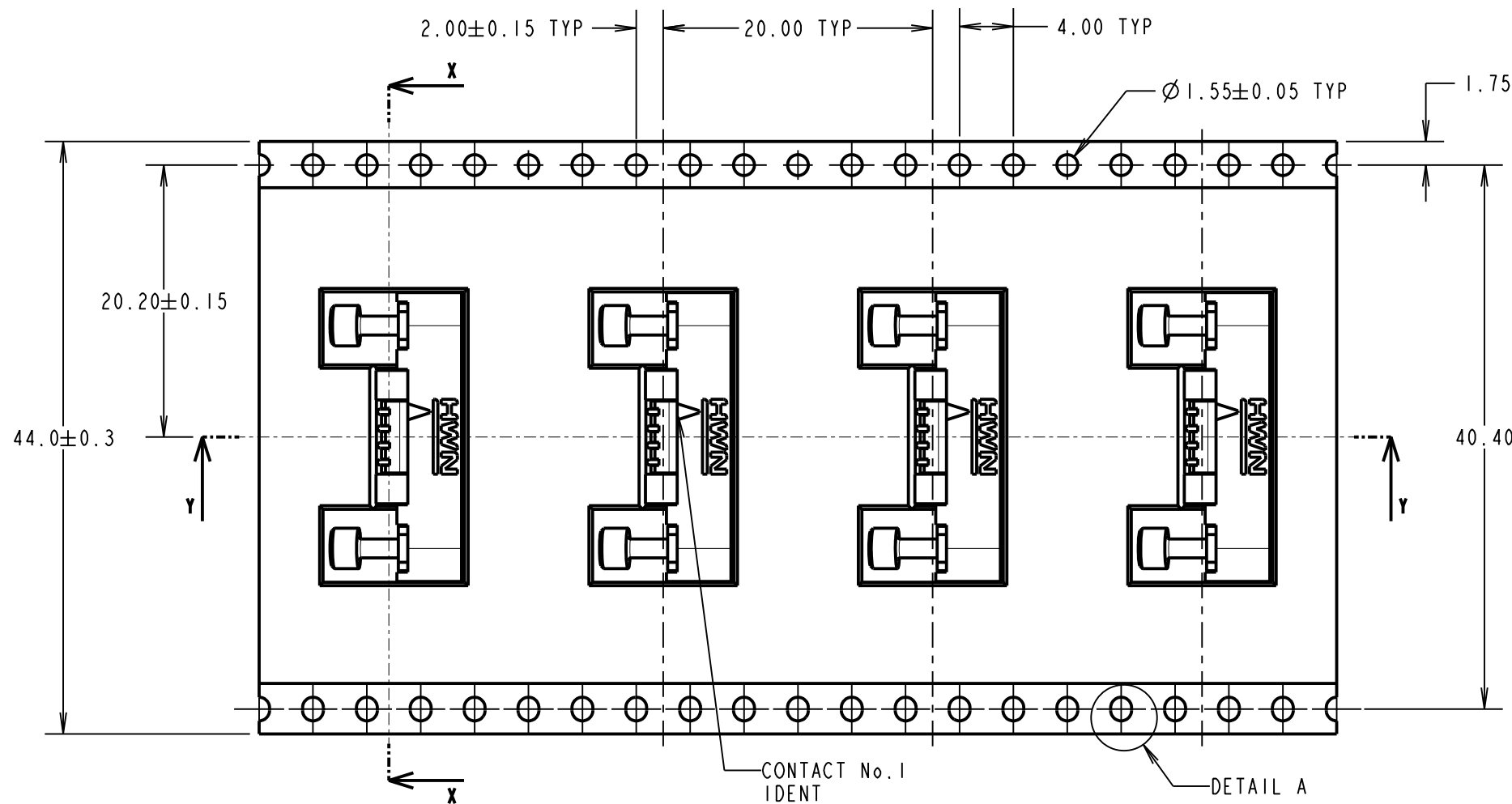

DETAIL A
(SCALE 10)

TAPE STRIP DETAILS ONLY, SEE SHEET 3 FOR CONNECTOR AND PCB LAYOUT DETAILS

NOTES:

2. COMPONENTS ARE ORIENTATED IN TAPE POCKETS AS SHOWN.
3. COMPONENTS ARE SUPPLIED IN STRIPS OF TAPE. SUPPLIED QUANTITY MAY CONSIST OF MORE THAN ONE STRIP. STRIP LENGTH MAY VARY.
4. LARGE QTY'S MAY BE SHIPPED ON A REEL AND MAY NOT HAVE A LEADER.
5. FOR PARTS ON REEL SUITABLE FOR AUTOMATIC MACHINE PLACEMENT PLEASE ORDER: G125-MHX0805M3-IADIADR.

MR	2	27.02.20	30006
NAME	ISS.	DATE	C/NOTE
APPROVED: M.RUDKIN			
CHECKED: R.PORTLOCK			
DRAWN: MARK G PLESTED			
CUSTOMER REF.:			
ASSEMBLY DRG:			

HARWIN

www.harwin.com
technical@harwin.com

THIS DRAWING AND ANY INFORMATION OR DESCRIPTIVE MATTER SET OUT HEREON ARE CONFIDENTIAL AND COPYRIGHT PROPERTY OF THE HARWIN GROUP AND MUST NOT BE DISCLOSED, LOANED, COPIED OR USED FOR MANUFACTURING, TENDERING OR FOR ANY OTHER PURPOSE WITHOUT THEIR WRITTEN PERMISSION.

TOLERANCES

X. = ± 1 mm
X.X = ± 0.50 mm
X.XX = ± 0.20 mm
X.XXX = ± 0.01 mm
ANGLES = $\pm 5^\circ$
UNLESS STATED

MATERIAL:

SEE ABOVE

FINISH:

SEE ABOVE

S/AREA:

mm²

TITLE:

G125 MT SERIES MALE
HORIZONTAL PC TAIL CONNECTOR

DRAWING NUMBER:

G125-MHX0805M3-IADIADP

SHT

4 OF 4