

PART NUMBER	REVISION	DESCRIPTION	FEED TYPE
2151824-2	F	FINE CRIMP HEIGHT ADJUST	PNEUMATIC
7-2151824-2	F	PNEUMATIC AND CRIMP TOOLING KIT	PNEUMATIC
7-2151824-7	A	CRIMP TOOLING KIT	-

ATLANTIC VERSION TERMINATOR INTERFACE ADAPTER

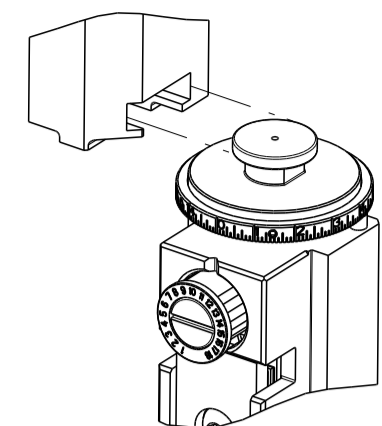

APPLICATOR DATA		
CRIMP	SIZE	TYPE
WIRE	5.40 mm [.213]	F
INSUL	9.75 mm [.384]	O

APPLICATOR INSTRUCTIONS 408-35042

TERMINAL DATA: LEAR TERMINAL		G&H CRIMP SPECIFICATION	
TERMINAL NAME: FLAT CONTACT			
WIRE STRIP LENGTH		INSULATION DIAMETER RANGE	
8.69-9.47 mm [.342-.373 IN]		Ø4.70-5.10 mm [.185-.201 IN]	
TERMINAL APPLICATION SPECIFICATION	NONE		

TERMINALS APPLIED				SEAL INSULATION DIAMETER RANGE
TE TERMINAL	LEAR TERMINAL	TE SEAL	VW SEAL	
1572974-1	28459306189	1949052-1	0211172A	4.0-4.3

WIRE SIZE	CRIMP HEIGHT mm [INCH]	CRIMP HEIGHT REFERENCE SETTING
10.00mm2	3.30 +/- 0.10 [.130 +/- .004]	6.3
6.00mm2	3.00 +/- 0.05 [.118 +/- .002]	9.3

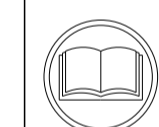

- 1 RECOMMENDED SPARE PARTS
- 2 REFER TO SUPPLIED INSTRUCTION SHEET FOR CLEANING, LUBRICATION AND STORAGE OF APPLICATOR.
- 3 APPLY PART NUMBER 2-23419-6 LOCTITE TO THREADS OF ITEM 242. PLY PART NUMBER 1-23419-5 LOCTITE TO THREADS OF ITEM 180.
- 4 CRIMP HEIGHT REFERENCE SETTING WAS THE SETTING USED WHEN THE APPLICATOR WAS QUALIFIED AT THE FACTORY. ADJUSTMENT MAY BE NECESSARY WHEN RUNNING APPLICATOR IN THE FIELD.
- 5 TERMINAL PITCH NOT COMPATIBLE WITH MECHANICAL FEED.
- 6. UNLESS SPECIFIED OTHERWISE TORQUE VALUES SHALL BE USED PER DOCUMENT, 101-35000.
- 7 APPLY TORO-SEAL IN ALLEN SOCKET TO FILL HOLE AFTER SOCKET HD HAS BEEN ADJUSTED TO CORRECT HEIGHT AT QUALIFICATION. APPLY #1-23419-5 LOC-TITE TO THREADS.
- 8 CUT TO LENGTH AT ASSEMBLY.

**\*WARNING**  
 ON INSTALLATION, SET WIRE DISC TO CRIMP HEIGHT REFERENCE SETTING FOR LARGEST WIRE SIZE. CRIMP HEIGHT REFERENCE SETTINGS GREATER THAN THE VALUE SHOWN MAY CAUSE DAMAGE TO THE CRIMP TOOLING. REFER TO THE INSTRUCTION SHEET FOR PROPER SETUP AND ADJUSTMENTS.

**ATLANTIC VERSION**  
 Shown on sheets 1 of 4 & 2 of 4  
 (Pacific version shown on sheets 3 of 4 & 4 of 4)

LOC	DIST	REVISIONS					
A	66	P	LTN	DESCRIPTION	DATE	OWN	APVD
		C		ECR-19-007970	19MAY2019	TB	TE
		D		ECR-19-012538	09AUG2019	MZ	YY
		E		ECR-20-008833	22JUN2020	FJ	TE
		F		ECR-20-009617	06JUL2020	TB	GB

-	2	2	2168083-1	SCR, SKT HD CAP, RoHS, M3 X 8.0	265
-	1	1	1633782-3	FENCE	264
-	2	2	22281-8	SPRING, COMPRESSION	263
-	1	1	240792-1	DRAG, TERMINAL	262
-	1	1	2-690438-2	FRONT STRIP GUIDE	261
-	1	1	2119641-1	FEED CAM, AIR FEED	248
-	1	1	2119082-9	CAM, SNAIL, INSULATION ADJUSTMENT	244
-	1	1	2079764-1	WASHER, WAVE SPRING, CREST-TO-CREST	243
-	1	1	2119083-1	RETAINER, INSULATION DIAL	242
-	1	1	2844940-6	AIR FEED MODULE	238
-	1	1	2-1752354-7	STANDOFF, HOLD-DOWN	180
-	1	1	993111-1	PIN, SLOTTED SPRING 3.0 X 20.0	177
-	1	1	8-22280-7	SPRING, COMPRESSION	176
-	1	1	1752353-2	GUIDE PIN, HOLDDOWN	175
-	1	1	1901680-2	GUIDE PIN, HOLDDOWN	174
-	REF	REF	994970-2	COUNTER, MAGNETIC	164
-	1	1	2844908-1	SCREW, LOCKING	99
-	1	1	2844907-1	POST, LOCKING	98
-	1	1	455888-5	SPACER, CRIMPER	82
-	2	2	2079383-4	SCR, BHSC, RoHS (M4 X 8)	79
-	1	1	1803096-1	EXTENSION PLATE	78
-	1	1	1803607-3	DOCUMENTATION PACKAGE	71
-	1	1	2119740-1	TAG, IDENTIFICATION	67
-	2	2	2168078-1	SCREW, DRIVE, RH, RoHS, 2 x .188	66
-	1	1	2168083-2	SCR, SKT HD CAP, RoHS, M4 X 8.0	60
-	1	1	5-18022-5	SCR, HEX HD CAP, M4 X 6.0	59
-	1	1	1-2168083-3	SCR, SKT HD CAP, RoHS, M3 X 16	57
-	1	1	1-1338683-1	FEED PAWL	56
-	4	4	2168083-3	SCR, SKT HD CAP, RoHS, M4 X 12.0	54
-	1	1	1-5018030-0	NUT, HEX, REG, RoHS, M3.5	52
-	1	1	1901681-2	HOLDDOWN, TERMINAL	51
-	1	1	18023-9	SCR, SKT HD CAP M4 X 6.0	49
-	1	1	1-1803583-7	APPLICATOR BASIC ASSEMBLY, SF	46
-	1	1	1803515-2	RAM ASSEMBLY, SF ATLANTIC	44
-	1	1	1803602-2	SCR, BHSC, RoHS (M8 X 40)	41
-	1	1	5-1752356-7	SUPPORT, TERMINAL	34
-	2	2	1-2079383-3	SCR, BHSC, RoHS (M4 X 25)	33
-	2	2	3-2844962-7	SPACER, CYLINDRICAL, STRIP GUIDE	30
-	1	1	2844992-5	ASSEMBLY, STRIP GUIDE	29
-	1	1	1-455888-0	SPACER, CRIMPER	28
-	1	1	1320928-2	STRIP GUIDE	24
-	1	1	2168083-2	SCR, SKT HD CAP, RoHS, M4 X 8.0	21
-	2	2	1-18028-2	WASHER, FLAT, REG M4	20
-	1	1	1803013-1	STRIPPER, SIDE FEED	19
-	1	1	3-22280-3	SPRING, COMPRESSION	12
-	1	1	1-356885-4	STOP, SHEAR	11
-	1	1	2-2119805-5	SHEAR HOLDER, FRONT	10
-	1	1	1-318059-5	FLOATING SHEAR, FRONT	9
1	2	1	1-1633930-5	ANVIL, COMBINATION	8
-	-	-	-	-	7
-	-	-	-	-	6
-	1	1	1803080-1	DEPRESSOR, SHEAR	5
-	1	1	238011-3	BLOCK, CRIMPER SPACER	4
1	2	1	4-1633965-7	CRIMPER, INSULATION O PREMIUM	3
-	1	1	1-455888-8	SPACER, CRIMPER	2
1	2	1	6-1633609-9	CRIMPER, WIRE	1

DIMENSIONS:		TOLERANCES UNLESS OTHERWISE SPECIFIED:		MATERIAL:		FINISH:	
mm	0 PLC ±	1 PLC ±	2 PLC ±	3 PLC ±	4 PLC ±	ANGLES ±	FINISH ±

OWN	C. CHEN	18DEC2012
CHK	S. XI	18DEC2012
APVD	J. CRUZ	18DEC2012
PRODUCT SPEC		
APPLICATION SPEC		
SIZE	A1	00779
CAGE CODE	2151824	
DRAWING NO	2151824	
RESTRICTED TO		
WEIGHT		
Customer Accessible Production Drawing	SCALE	1:2
SHEET	1	OF 4
REV	F	

LOC	DIST	REVISIONS					
		P	LTN	DESCRIPTION	DATE	DWN	APVD
A	66	-	-	SEE SHEET 1	-	-	-

### FEED TYPE PNEUMATIC

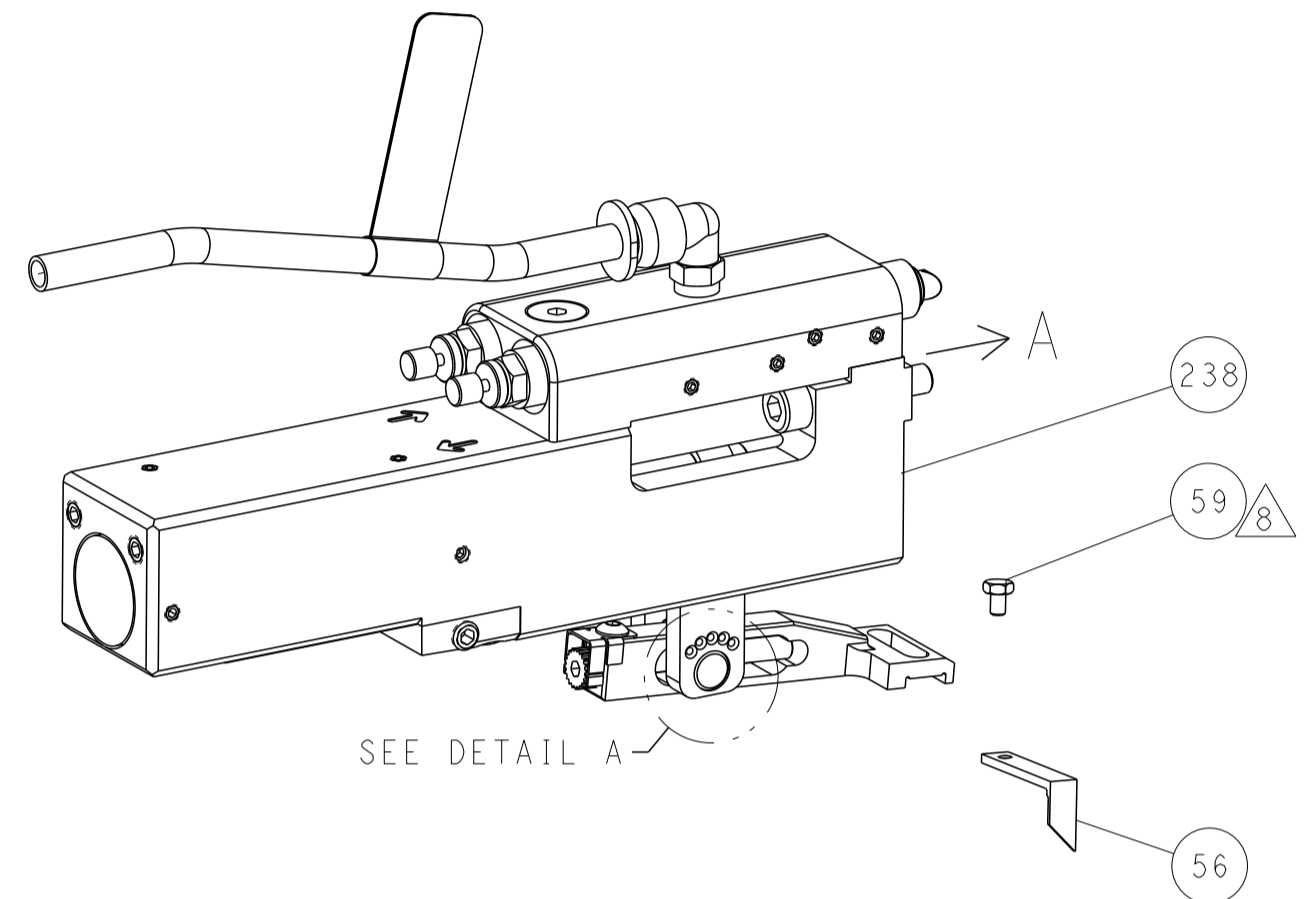

### FEED SPRING SETTING POSITION (SHOWN FROM REAR SIDE)

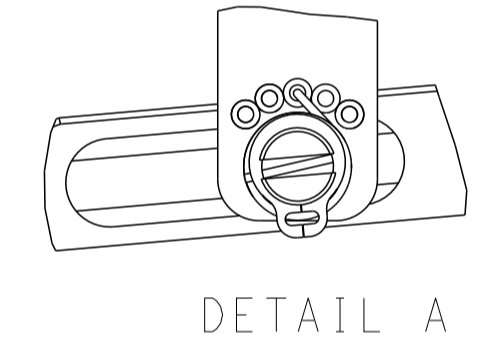

### CAM POSITION

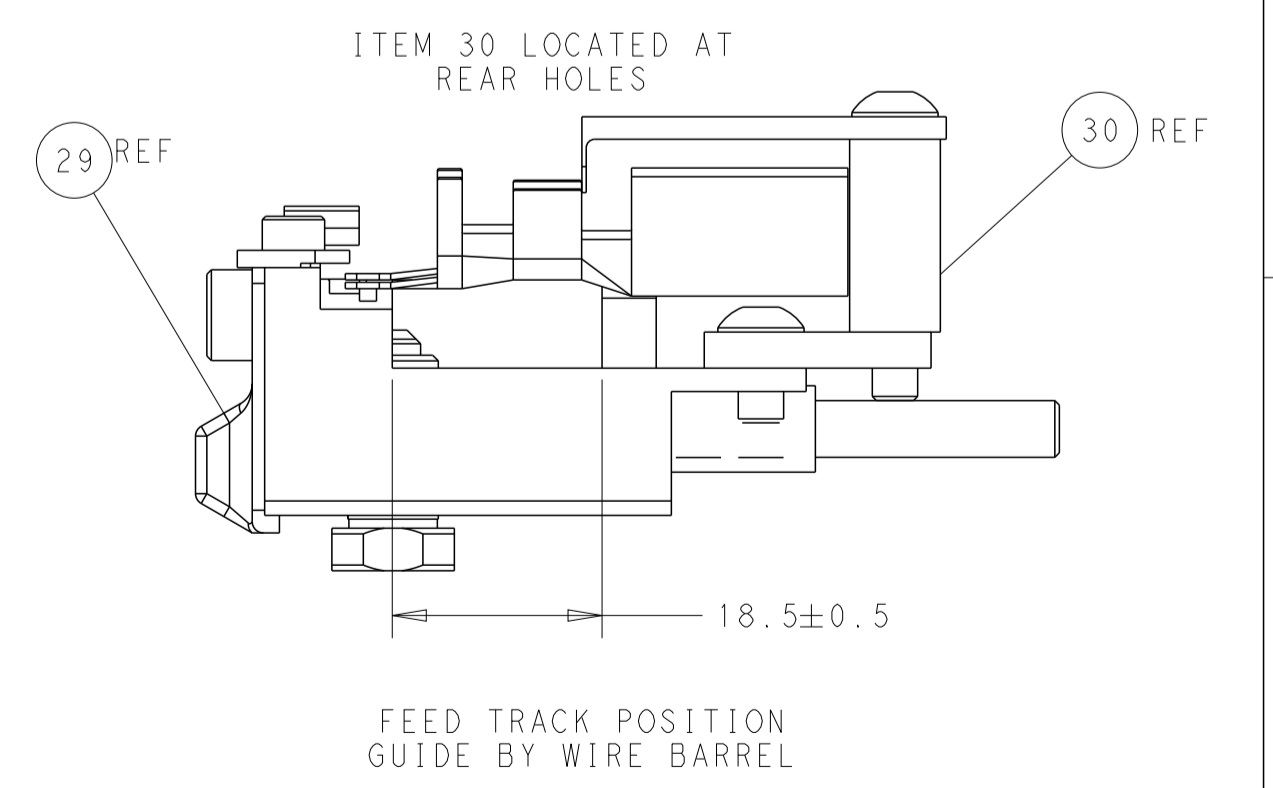
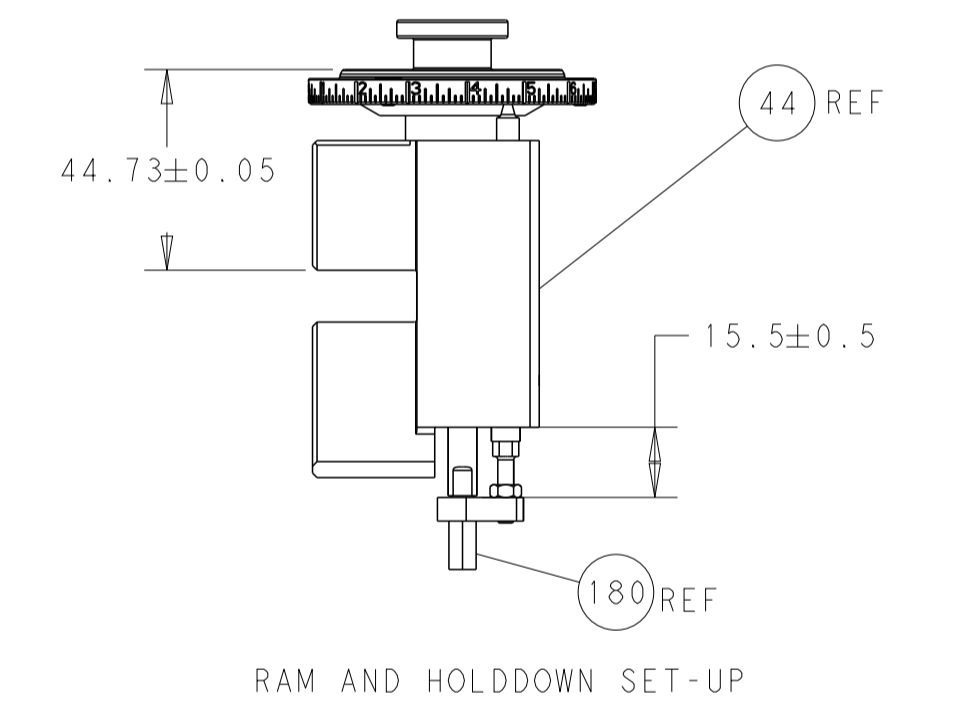
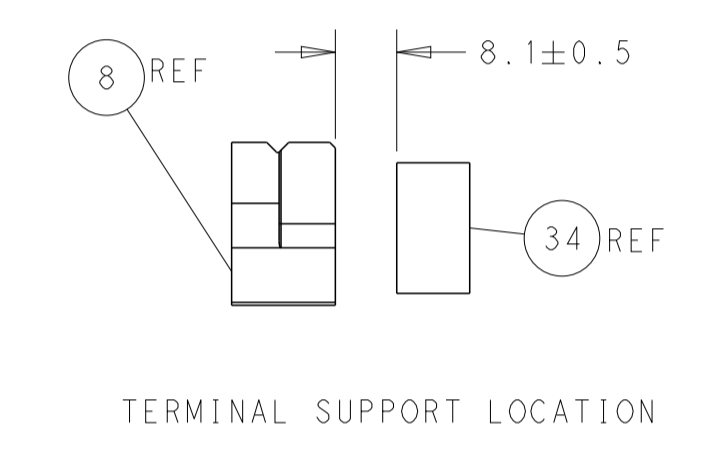
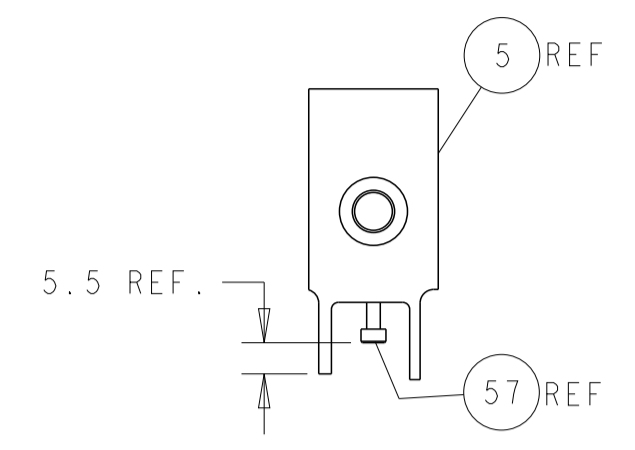
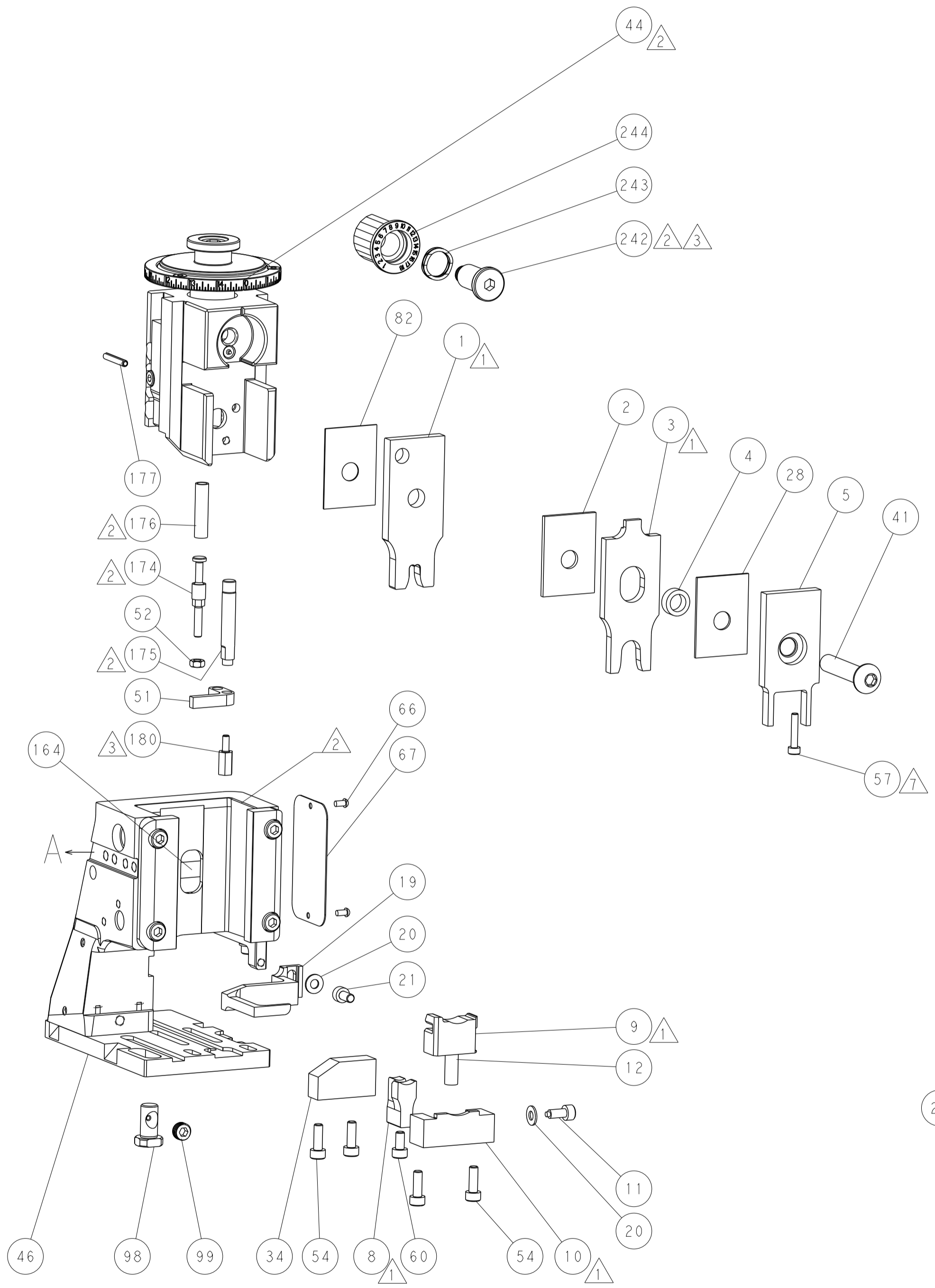
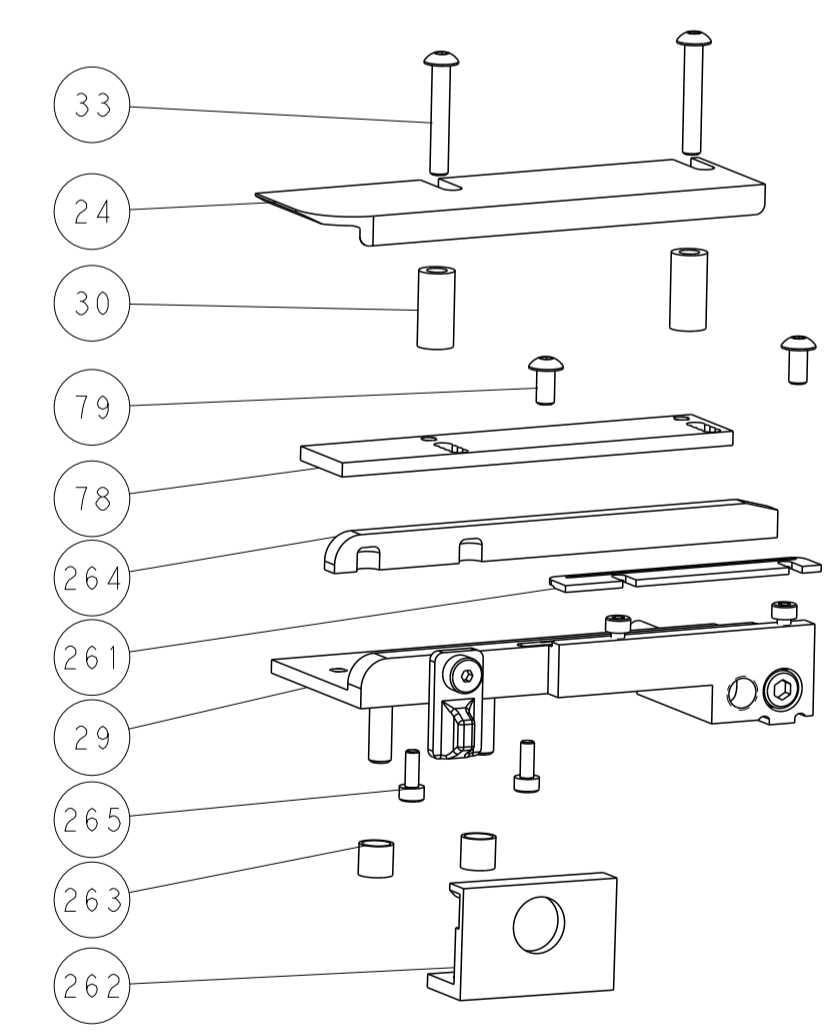
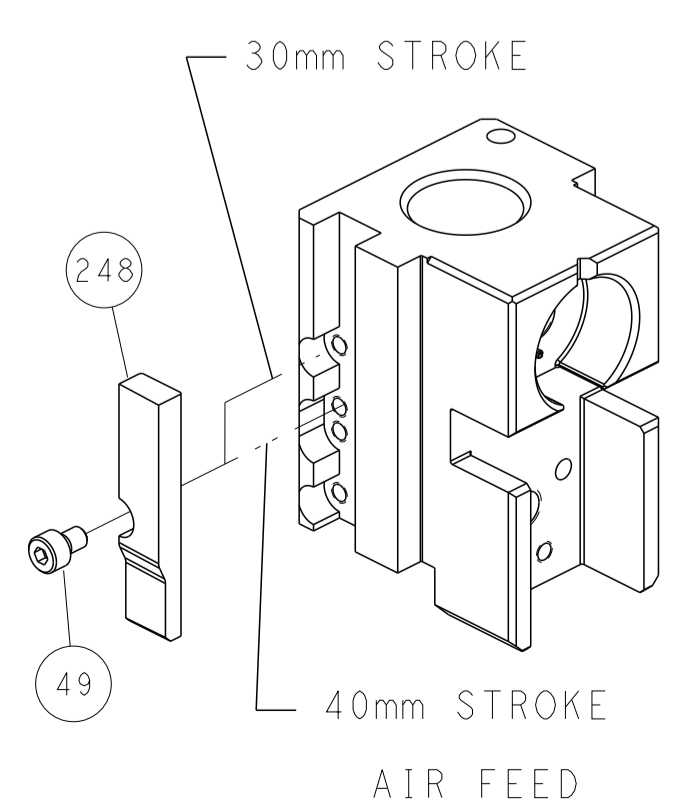

**ATLANTIC VERSION**  
 Shown on sheets 1 of 4 & 2 of 4  
 (Pacific version shown on sheets 3 of 4 & 4 of 4)

DIMENSIONS:		TOLERANCES UNLESS OTHERWISE SPECIFIED:		DWN C. CHEN 18DEC2012		TE Connectivity	
mm		0 PLC	±	CHK S. XI 18DEC2012		Harrisburg, PA 17105-3608	
Ø		1 PLC	±	APVD J. CRUZ 18DEC2012		NAME	
H		2 PLC	±	PRODUCT SPEC		Ocean Side Feed Applicator	
L		3 PLC	±	APPLICATION SPEC		SIZE CAGE CODE DRAWING NO	
R		4 PLC	±	MATERIAL		A1 00779 ©=2151824	
ANGLES		FINISH	±	WEIGHT		RESTRICTED TO	
FINISH		-		SCALE		SHEET 2 OF 4 REV F	
Customer Accessible Production Drawing				Customer Accessible Production Drawing			

PART NUMBER	REVISION	DESCRIPTION	FEED TYPE
2-2151824-2	F	FINE CRIMP HEIGHT ADJUST	PNEUMATIC
7-2151824-7	A	CRIMP TOOLING KIT	-

PACIFIC VERSION TERMINATOR  
 INTERFACE ADAPTER



APPLICATOR DATA		
CRIMP	SIZE	TYPE
WIRE	5.40 mm [.213]	F
INSUL	9.75 mm [.384]	O

APPLICATOR INSTRUCTIONS  
 408-35042

TERMINAL DATA: LEAR TERMINAL		G&H CRIMP SPECIFICATION	
TERMINAL NAME: FLAT CONTACT			
WIRE STRIP LENGTH		INSULATION DIAMETER RANGE	
8.69-9.47 mm [.342-.373 IN]		Ø4.70-5.10 mm [.185-.201 IN]	
TERMINAL APPLICATION SPECIFICATION		NONE	

TERMINALS APPLIED				SEAL INSULATION DIAMETER RANGE
TE TERMINAL	LEAR TERMINAL	TE SEAL	LEAR SEAL	
1572974-1	28459306189	1949052-1	0211172A	4.0-4.3

WIRE SIZE	CRIMP HEIGHT mm [INCH]	CRIMP HEIGHT REFERENCE SETTING
10.00mm <sup>2</sup>	3.30 +/- 0.10 [.130 +/- .004]	6.3
6.00mm <sup>2</sup>	3.00 +/- 0.05 [.118 +/- .002]	9.3



- 1 RECOMMENDED SPARE PARTS
- 2 REFER TO SUPPLIED INSTRUCTION SHEET FOR CLEANING, LUBRICATION AND STORAGE OF APPLICATOR.
- 3 APPLY PART NUMBER 2-23419-6 LOCTITE TO THREADS OF ITEM 242. APPLY PART NUMBER 1-23419-5 LOCTITE TO THREADS OF ITEM 180.
- 4 CRIMP HEIGHT REFERENCE SETTING WAS THE SETTING USED WHEN THE APPLICATOR WAS QUALIFIED AT THE FACTORY. ADJUSTMENT MAY BE NECESSARY WHEN RUNNING APPLICATOR IN THE FIELD.
- 5 TERMINAL PITCH NOT COMPATABLE WITH MECHANICAL FEED.
- 6. UNLESS SPECIFIED OTHERWISE TORQUE VALUES SHALL BE USED PER DOCUMENT, 101-35000.
- 7 APPLY TORO-SEAL IN ALLEN SOCKET TO FILL HOLE AFTER SOCKET HD HAS BEEN ADJUSTED TO CORRECT HEIGHT AT QUALIFICATION. APPLY #1-23419-5 LOC-TITE TO THREADS.
- 8 CUT TO LENGTH AT ASSEMBLY.

**\*WARNING**  
 ON INSTALLATION, SET WIRE DISC TO CRIMP HEIGHT REFERENCE SETTING FOR LARGEST WIRE SIZE. CRIMP HEIGHT REFERENCE SETTINGS GREATER THAN THE VALUE SHOWN MAY CAUSE DAMAGE TO THE CRIMP TOOLING. REFER TO THE INSTRUCTION SHEET FOR PROPER SETUP AND ADJUSTMENTS.

**PACIFIC VERSION**  
 Shown on sheets 3 of 4 & 4 of 4  
 (Atlantic version shown on sheets 1 of 4 & 2 of 4)

LOC	DIST	REVISIONS					
		P	LTN	DESCRIPTION	DATE	OWN	APVD
A	66	-	-	SEE SHEET 1	-	-	-

-	2	2168083-1	SCR, SKT HD CAP, RoHS, M3 X 8.0	265	
-	1	1633782-3	FENCE	264	
-	2	22281-8	SPRING, COMPRESSION	263	
-	1	240792-1	DRAG, TERMINAL	262	
-	1	2-690438-2	FRONT STRIP GUIDE	261	
-	1	2119082-9	CAM, SNAIL, INSULATION ADJUSTMENT	244	
-	1	2079764-1	WASHER, WAVE SPRING, CREST-TO-CREST	243	
3	-	1	2119083-1	RETAINER, INSULATION DIAL	242
-	1	2844940-6	AIR FEED MODULE	238	
3	-	1	2-1752354-7	STANDOFF,HOLD-DOWN	180
-	1	993111-1	PIN, SLOTTED SPRING 3.0 X 20.0	177	
-	1	8-22280-7	SPRING, COMPRESSION	176	
-	1	1752353-2	GUIDE PIN,HOLDDOWN	175	
-	1	1901680-2	GUIDE PIN,HOLDDOWN	174	
-	REF	994970-2	COUNTER, MAGNETIC	164	
-	1	2119641-2	FEED CAM, AIR FEED	151	
-	1	2168083-8	SCR, SKT HD CAP, RoHS, M4 X 16	144	
-	4	2168083-9	SCR, SKT HD CAP, RoHS, M4 X 20	143	
-	1	1-1803583-8	APPLICATOR BASIC ASSEMBLY, SF	141	
-	1	1803516-2	RAM ASSEMBLY, SF PACIFIC	140	
-	1	2844908-1	SCREW, LOCKING	99	
-	1	2844907-1	POST, LOCKING	98	
-	1	455888-5	SPACER, CRIMPER	82	
-	2	2079383-4	SCR, BHSC, RoHS (M4 X 8)	79	
-	1	1803096-1	EXTENSION PLATE	78	
-	1	1803607-3	DOCUMENTATION PACKAGE	71	
-	1	2119740-1	TAG,IDENTIFICATION	67	
-	2	2168078-1	SCREW, DRIVE, RH, RoHS, 2 x .188	66	
6	-	1	5-18022-5	SCR, HEX HD CAP, M4 X 6.0	59
7	-	1	1-2168083-3	SCR, SKT HD CAP, RoHS, M3 X 16	57
-	1	1-1338683-1	FEED PAWL	56	
-	1	1-5018030-0	NUT, HEX, REG, RoHS, M3.5	52	
-	1	1901681-2	HOLDDOWN, TERMINAL	51	
-	1	18023-9	SCR, SKT HD CAP M4 X 6.0	49	
-	1	1803602-2	SCR, BHSC, RoHS (M8 X 40)	41	
-	1	5-1752356-7	SUPPORT, TERMINAL	34	
-	2	1-2079383-3	SCR, BHSC, RoHS (M4 X 25)	33	
-	2	3-2844962-7	SPACER, CYLINDRICAL, STRIP GUIDE	30	
-	1	2844992-5	ASSEMBLY, STRIP GUIDE	29	
-	1	1-455888-0	SPACER, CRIMPER	28	
-	1	1320928-2	STRIP GUIDE	24	
-	1	2168083-2	SCR, SKT HD CAP, RoHS, M4 X 8.0	21	
-	2	1-18028-2	WASHER, FLAT, REG M4	20	
-	1	1803013-1	STRIPPER, SIDE FEED	19	
-	1	3-22280-3	SPRING, COMPRESSION	12	
-	1	1-356885-4	STOP, SHEAR	11	
1	-	1	2-2119805-5	SHEAR HOLDER, FRONT	10
1	-	1	1-318059-5	FLOATING SHEAR, FRONT	9
1	1	1-1633930-5	ANVIL, COMBINATION	8	
-	-	-	-	7	
-	-	-	-	6	
-	1	1803080-1	DEPRESSOR, SHEAR	5	
-	1	238011-3	BLOCK, CRIMPER SPACER	4	
1	1	4-1633965-7	CRIMPER, INSULATION O PREMIUM	3	
-	1	1-455888-8	SPACER, CRIMPER	2	
1	1	6-1633609-9	CRIMPER, WIRE	1	

DIMENSIONS:		TOLERANCES UNLESS OTHERWISE SPECIFIED:		MATERIAL:		FINISH:		WEIGHT:		SCALE:		SHEET:		REV:	
mm	0 PLC ±	1 PLC ±	2 PLC ±	3 PLC ±	4 PLC ±	ANGLES	FINISH			A1	00779	3	4	F	

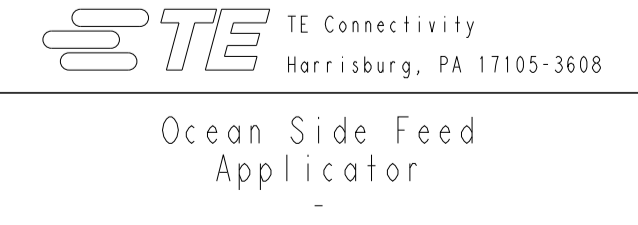

Ocean Side Feed  
 Applicator

LOC	DIST	REVISIONS					
		P	LTN	DESCRIPTION	DATE	DWN	APVD
A	66	-	-	SEE SHEET 1	-	-	-

### FEED TYPE PNEUMATIC

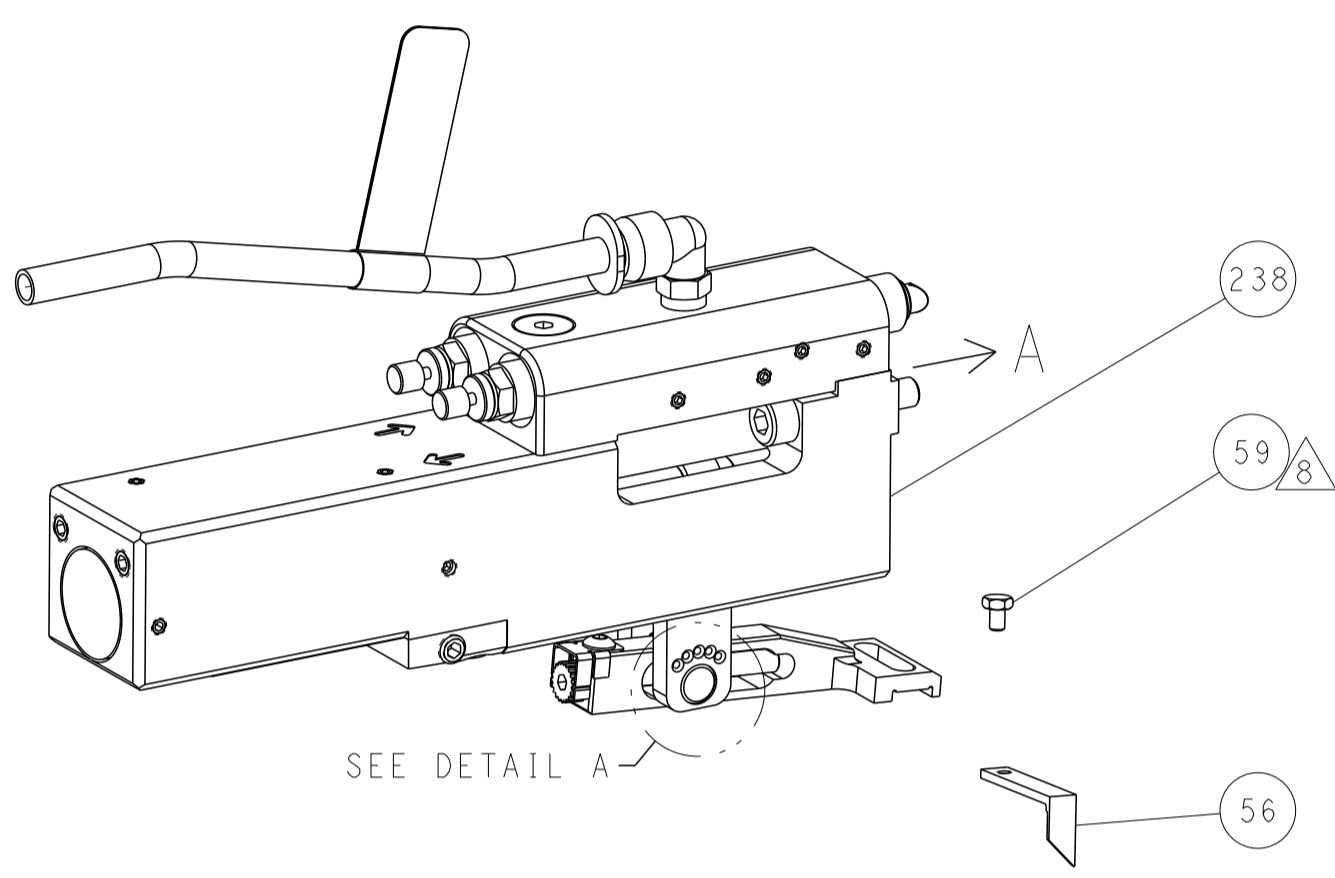

### FEED SPRING SETTING POSITION (SHOWN FROM REAR SIDE)

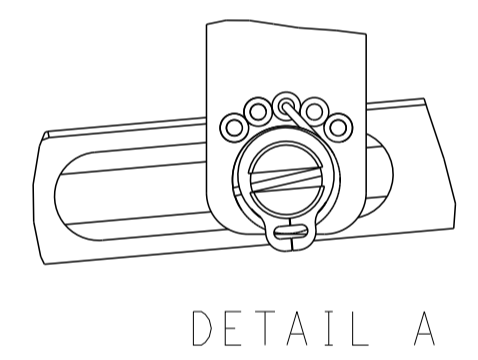

### CAM POSITION

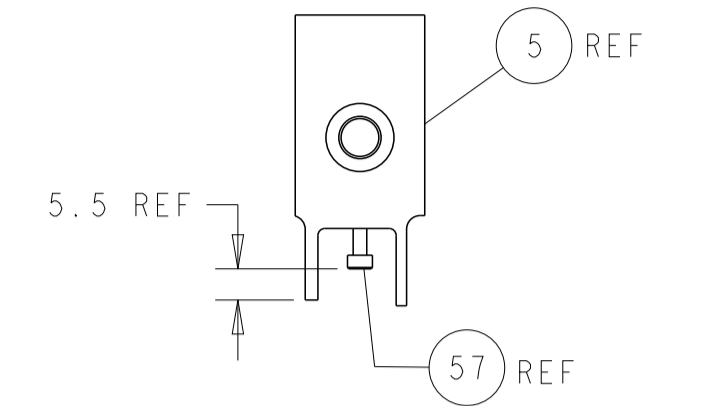
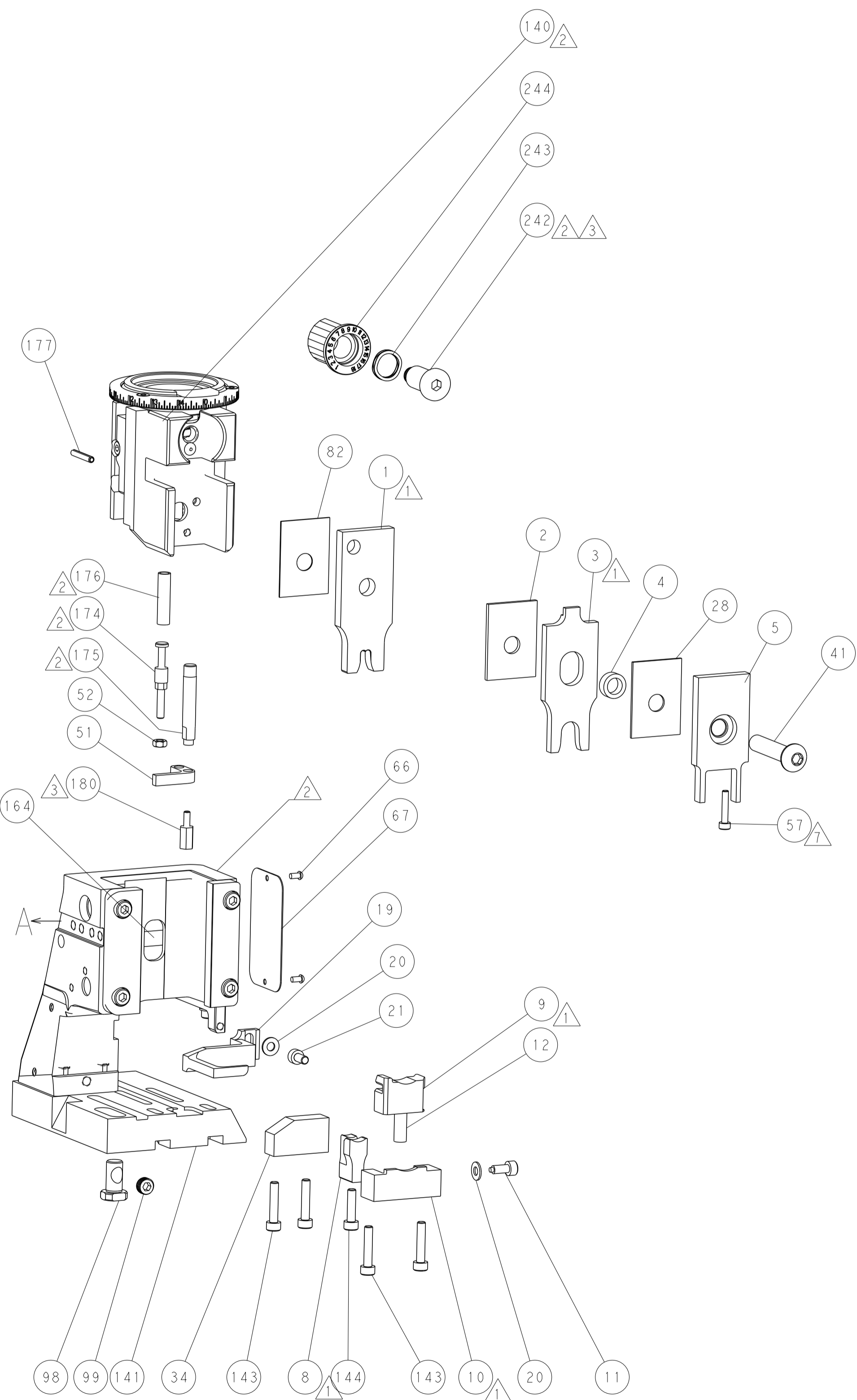
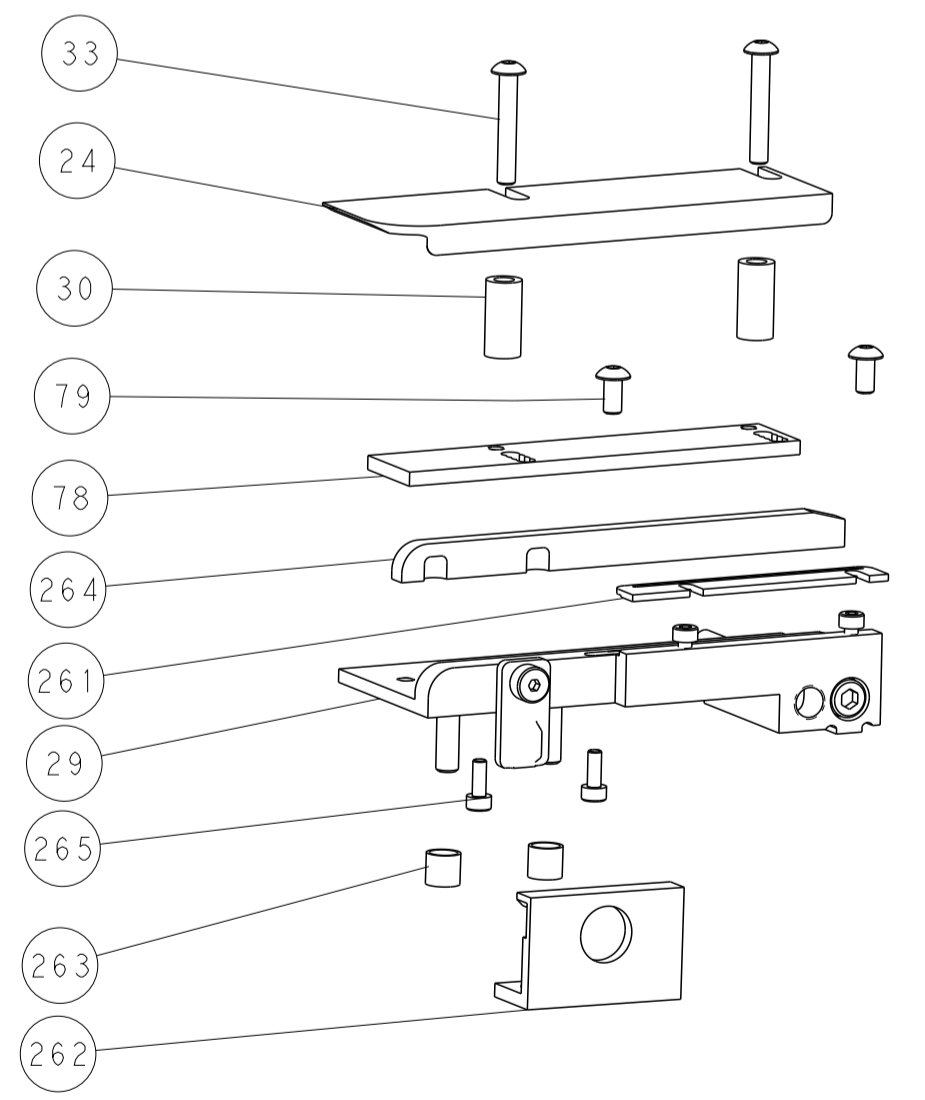
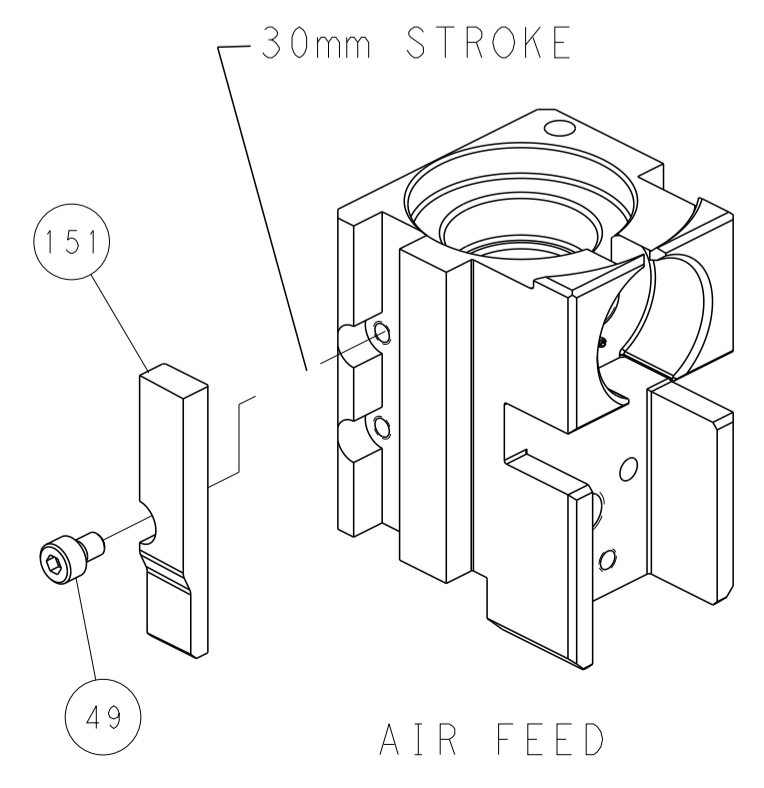

SHEAR DEPRESSOR DETAIL

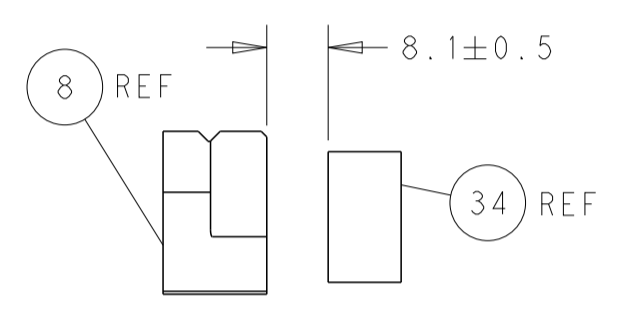

TERMINAL SUPPORT LOCATION

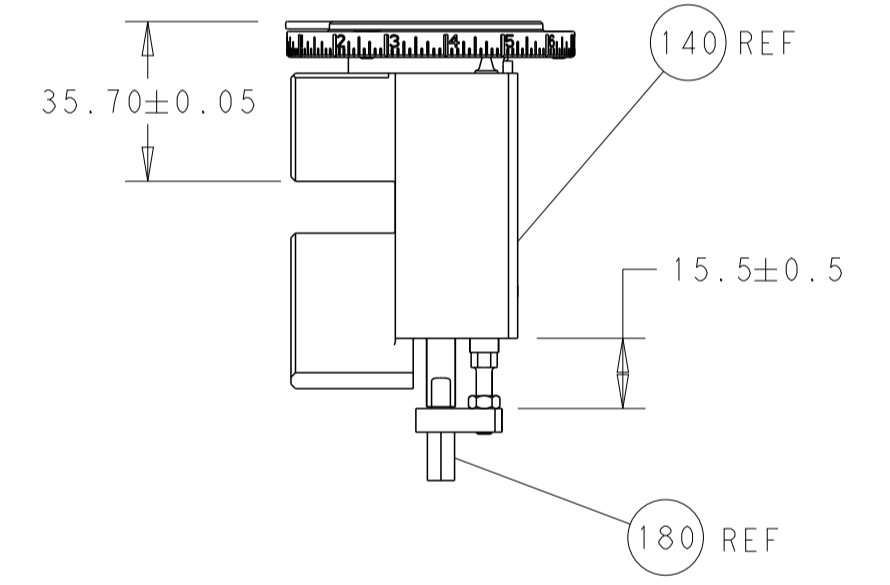

RAM AND HOLDDOWN SET-UP

ITEM 30 LOCATED AT REAR HOLES

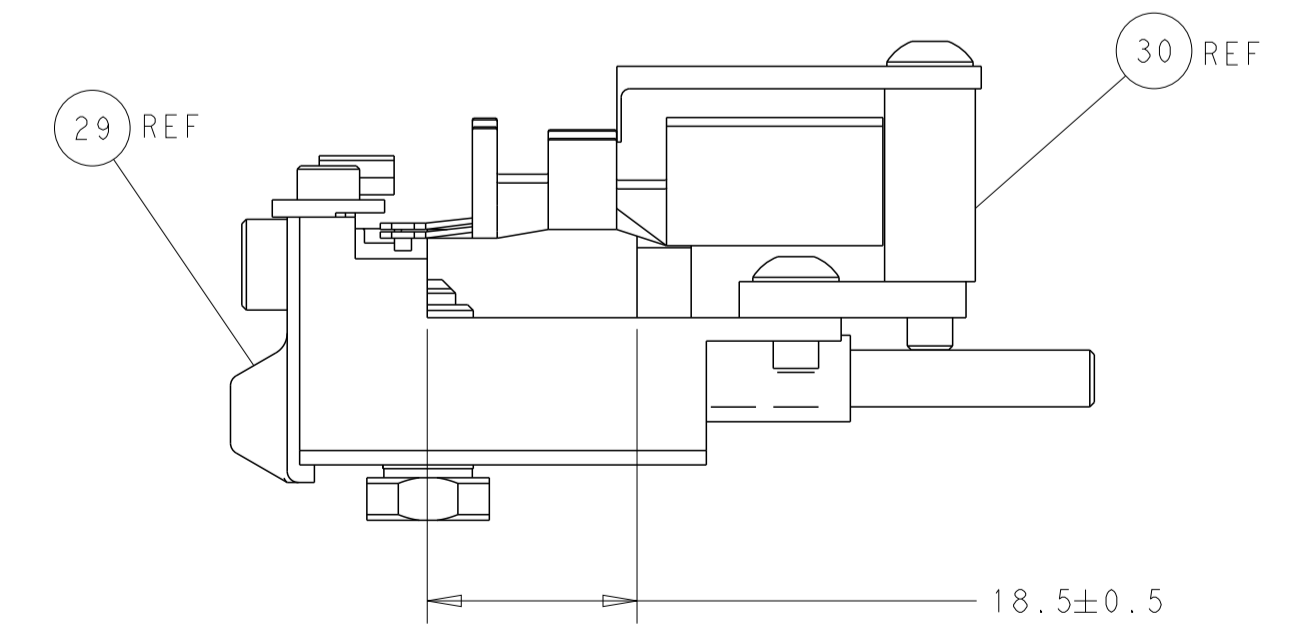

FEED TRACK POSITION GUIDE BY WIRE BARREL

**PACIFIC VERSION**  
 Shown on sheets 3 of 4 & 4 of 4  
 (Atlantic version shown on sheets 1 of 4 & 2 of 4)

<small>THIS DRAWING IS UNPUBLISHED. RELEASED FOR PUBLICATION. IT IS THE PROPERTY OF TYCO ELECTRONICS CORPORATION. IT IS TO BE USED ONLY FOR THE PURPOSES AND IN THE MANNER SPECIFIED BY THE DRAWING. IT IS NOT TO BE REPRODUCED OR TRANSMITTED IN ANY FORM OR BY ANY MEANS, ELECTRONIC OR MECHANICAL, INCLUDING PHOTOCOPYING, RECORDING, OR BY ANY INFORMATION STORAGE AND RETRIEVAL SYSTEM, WITHOUT THE WRITTEN PERMISSION OF TYCO ELECTRONICS CORPORATION.</small>		DWN: C. CHEN CHK: S. XI APVD: J. CRUZ	18DEC2012 18DEC2012 18DEC2012	NAME: Ocean Side Feed Applicator SIZE: A1 CAGE CODE: 00779 DRAWING NO: 2151824	RESTRICTED TO: F
DIMENSIONS: mm TOLERANCES UNLESS OTHERWISE SPECIFIED: 0 PLC ± 1 PLC ± 2 PLC ± 3 PLC ± 4 PLC ± ANGLES ± MATERIAL: - FINISH: -	WEIGHT: - SCALE: 1:2 SHEET: 4 OF 4 REV: F	Customer Accessible Production Drawing			