

REVISIONS					
P	LTR	DESCRIPTION	DATE	DWN	APVD
H1		REV. ECO 17-011267	11SEP2017	HC	KR

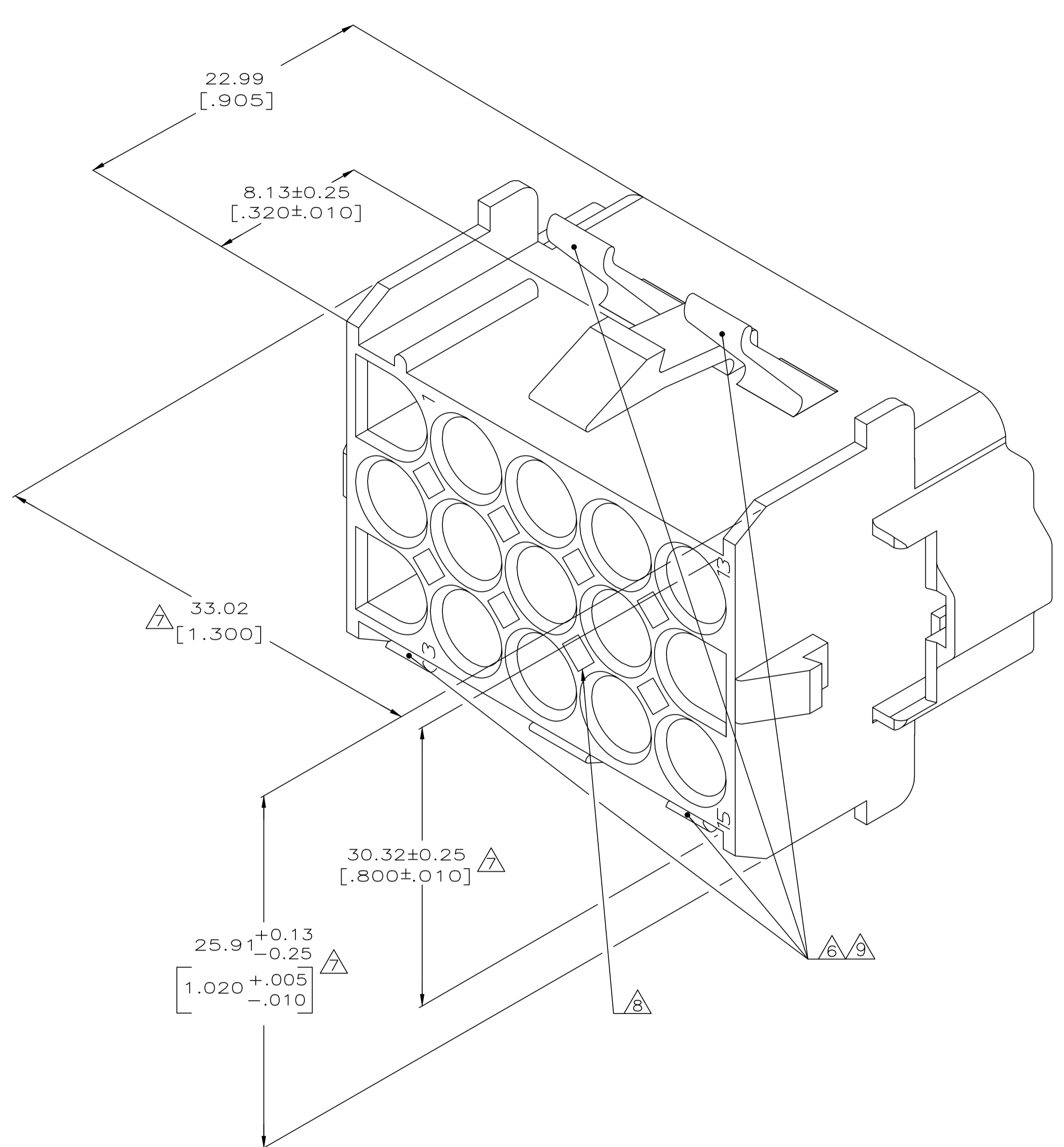

1. MUST BE ASSEMBLED WITH CAP REAR P/N 770058-1 BEFORE MATING. KIT P/N IS 770030-1.
- 2 RECOMMENDED PANEL THICKNESS 0.76-2.29 [.030-.090].
- 3 PANEL MUST BE PUNCHED SO THAT THE HOUSING ENTERS THE PANEL IN THE SAME DIRECTION AS THE PUNCH.
- 4 OPTIONAL FOR KEYING HOUSING IN PANEL.
- 5 CIRCUIT NUMBER 1 LOCATION.
- 6 AMP LOGO LOCATED ONCE ON ANY INDICATED SURFACE FARSIDE.
- 7 DIMENSION INDICATED IS AS MOLDED. ADDITIONAL GROWTH DUE TO SUBSEQUENT MOISTURE ABSORPTION MAY OCCUR.
- 8 OPTIONAL CONSTRUCTION PROVIDES ROUND MATERIAL REDUCTION CORING HOLES.
- 9 CSA LOGO LOCATED ONCE ON ANY INDICATED SURFACE

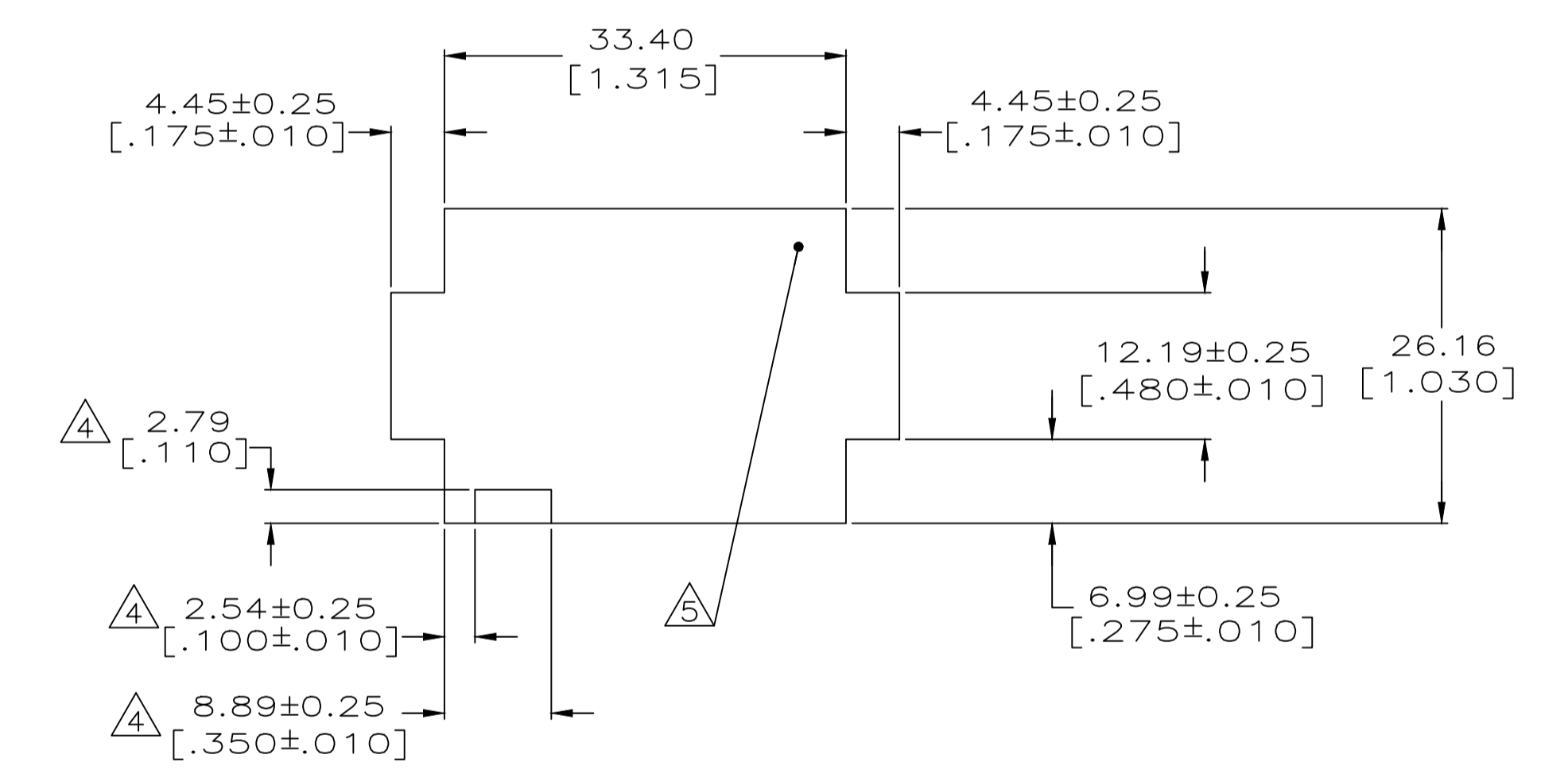

RECOMMENDED PANEL CUTOUT  
 (HOUSING ENTRY SIDE)  
 SCALE 2:1

770057-1  
 PART NUMBER

METRIC

THIS DRAWING IS A CONTROLLED DOCUMENT.		DWK 1-15-92	TE Connectivity	
DIMENSIONS: INCHES		CHK R. SWING 1-15-92	APVD M. TRULL 1-16-1992	
TOLERANCES UNLESS OTHERWISE SPECIFIED:		NAME		
0 PLC ± -	1 PLC ± -	PRODUCT SPEC		
2 PLC ± -	3 PLC ± 0.13 [.005]	APPLICATION SPEC		
4 PLC ± -	ANGLES ± -	SIZE CAGE CODE DRAWING NO		
MATERIAL NYLON,UL94V-0, FINISH -		WEIGHT 1	A1 00779	C=770057
		CUSTOMER DRAWING		RESTRICTED TO
		SCALE 5:1	SHEET 1 OF 1	REV H1