

SERPAC 152iAC (exploded isometric)

Electronic Enclosures

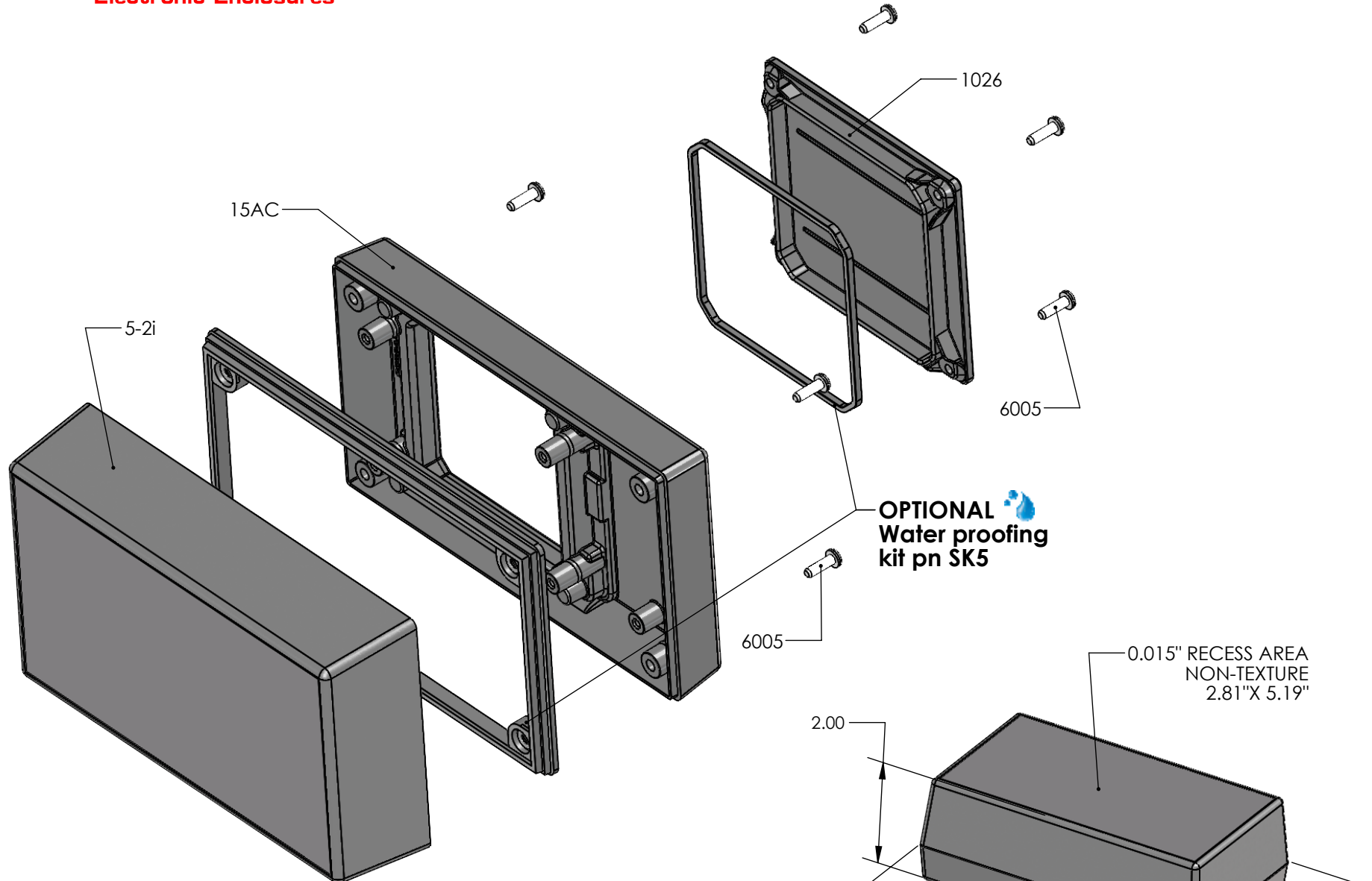

OPTIONAL
Water proofing
kit pn SK5

0.015" RECESS AREA
NON-TEXTURE
2.81"X 5.19"

PART NO.	DESCRIPTION (Included)	ACCESSORIES (Optional)	
5-2i	Top	PART NO.	DESCRIPTION
15AC	AC Bottom	50	Non-skid Feet
1026	Access Door	SK5	Seal Kit for 15X
6005	#4X3/8" Self-Tapping Screw (8)		

Notes: Enclosure weight .33 lb / 151 g
 1) Enclosure meets or exceeds IP40 and NEMA 1
 2) When used with SK5 the enclosure meets or exceeds IP 67 and NEMA 4X, 12 and 13 MIL-STD-810G 506.5 (.02 lb / 11g)
 3) Circuit Board drawings see sheet 3.
 4) All components are RoHS Compliant.

SERPAC 152iAC

Electronic Enclosures

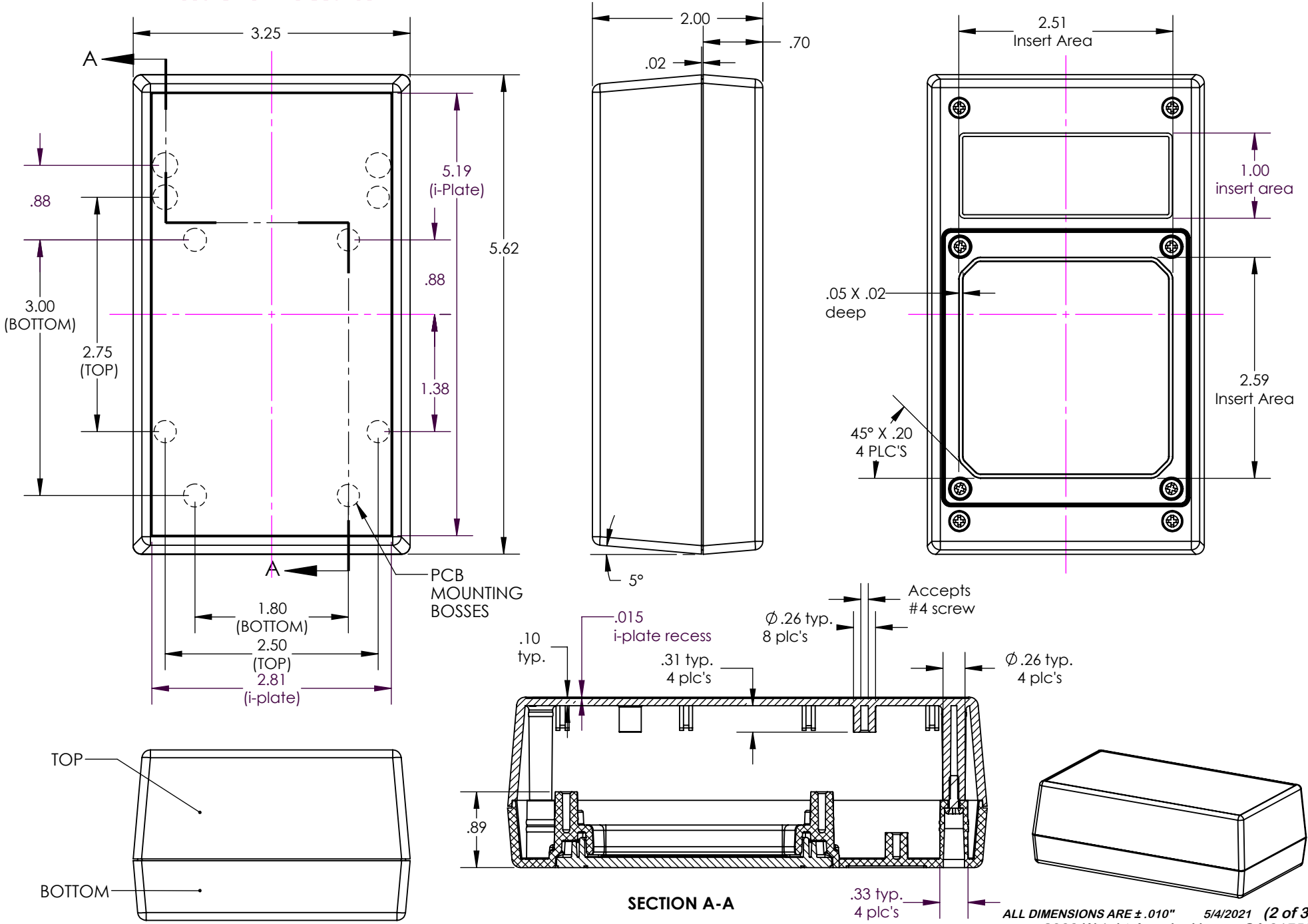

SECTION A-A

ALL DIMENSIONS ARE ±.010" 5/4/2021 (2 of 3)

2009 Wright Ave. La Verne, CA 91750

Ph. (626) 331-0517 Fx. (626) 331-8584 www.serpac.com

SERPAC PCB for 15X compartment enclosures

Electronic Enclosures

CIRCUIT BOARD FOR TOP

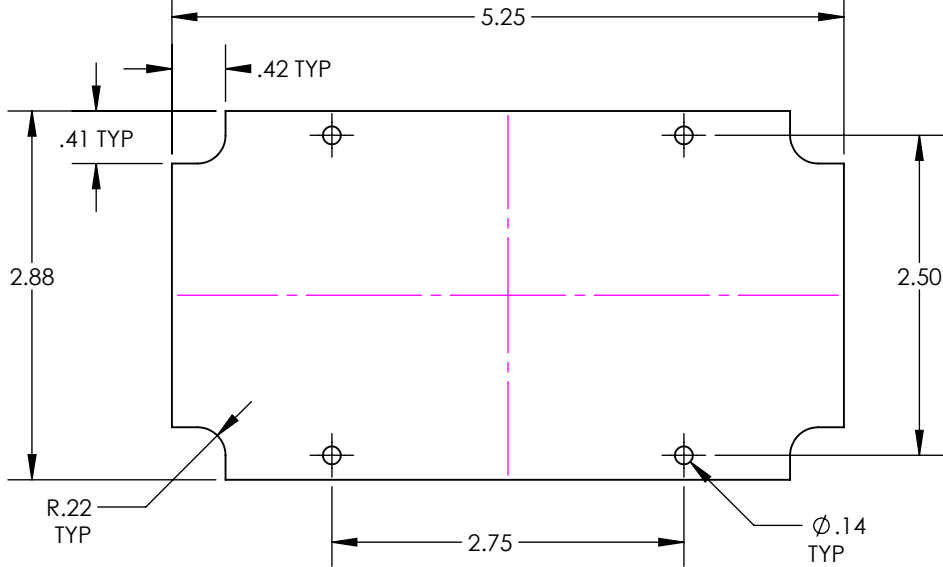

CIRCUIT BOARD FOR BOTTOM

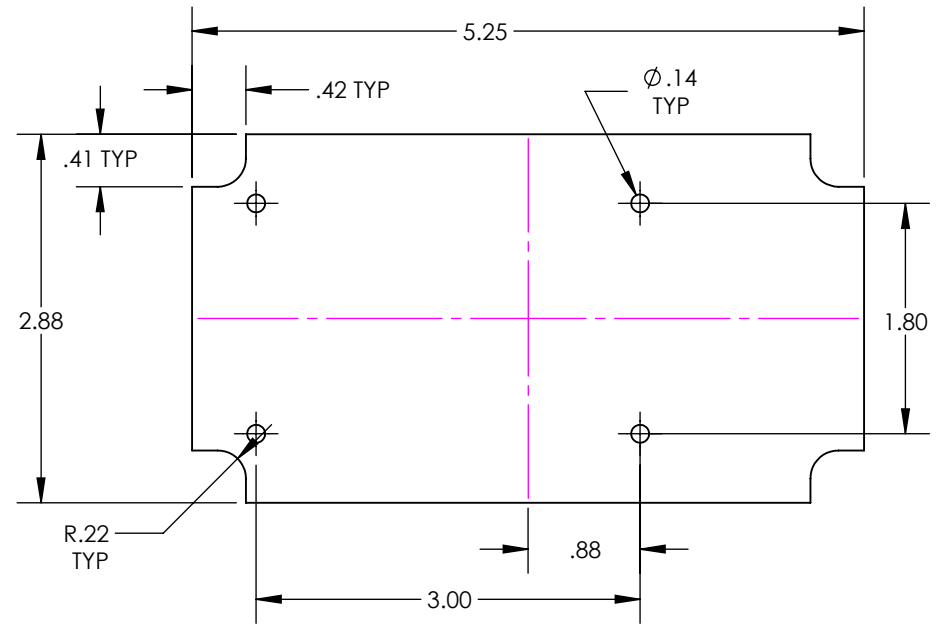

SMALL CIRCUIT BOARD FOR BOTTOM

