

P	LTR	DESCRIPTION	DATE	DWN	APVD
A1		RELEASE TO PRODUCTION	22SEP2022	SS	JDB
A2		DIMENSIONAL TOLERANCES REMOVED	28SEP2022	SS	JDB
A3		NOTE 3 ADDED (PROP 65 WARNING)	07FEB2023	SS	JDB

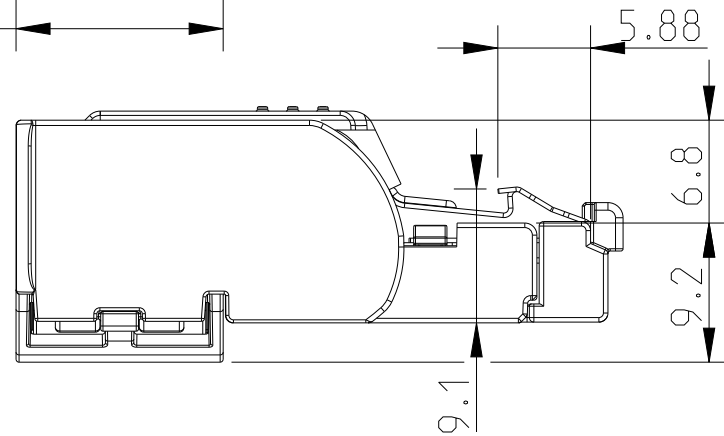

RECOMMENDED STRIPPING LENGTHS

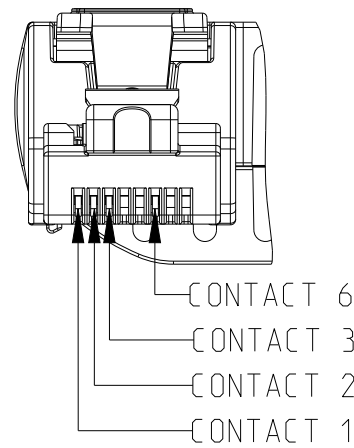
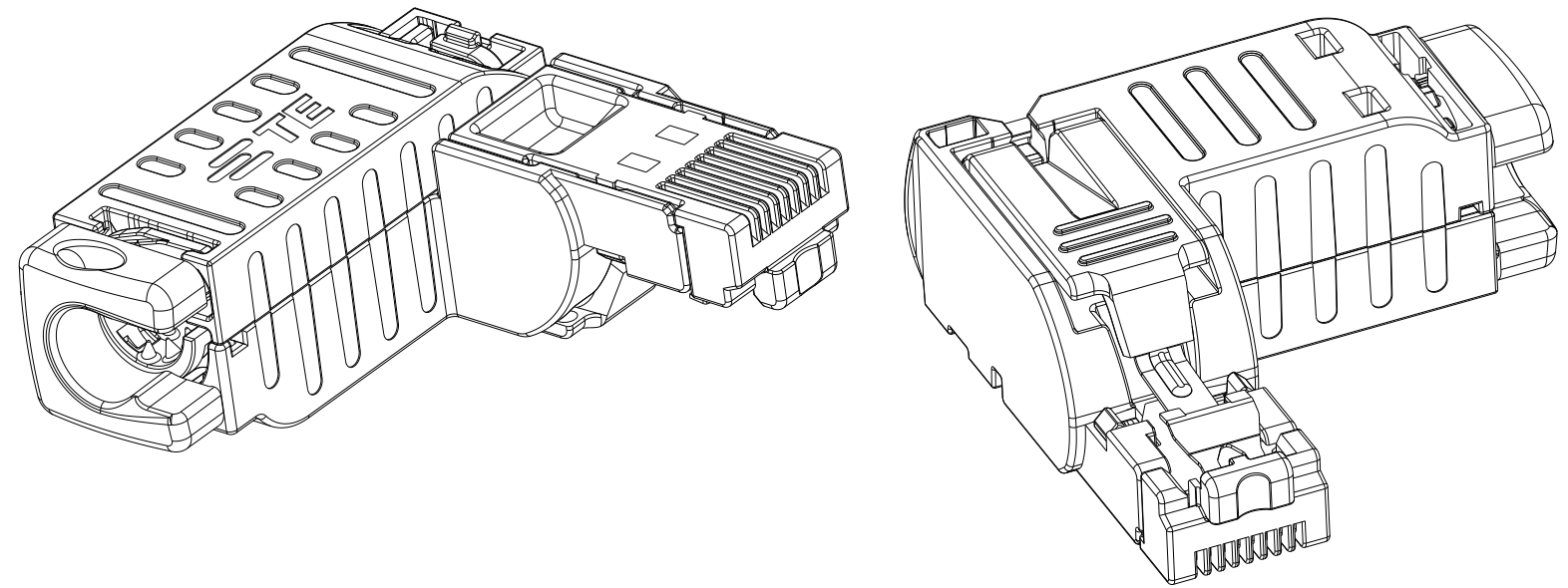
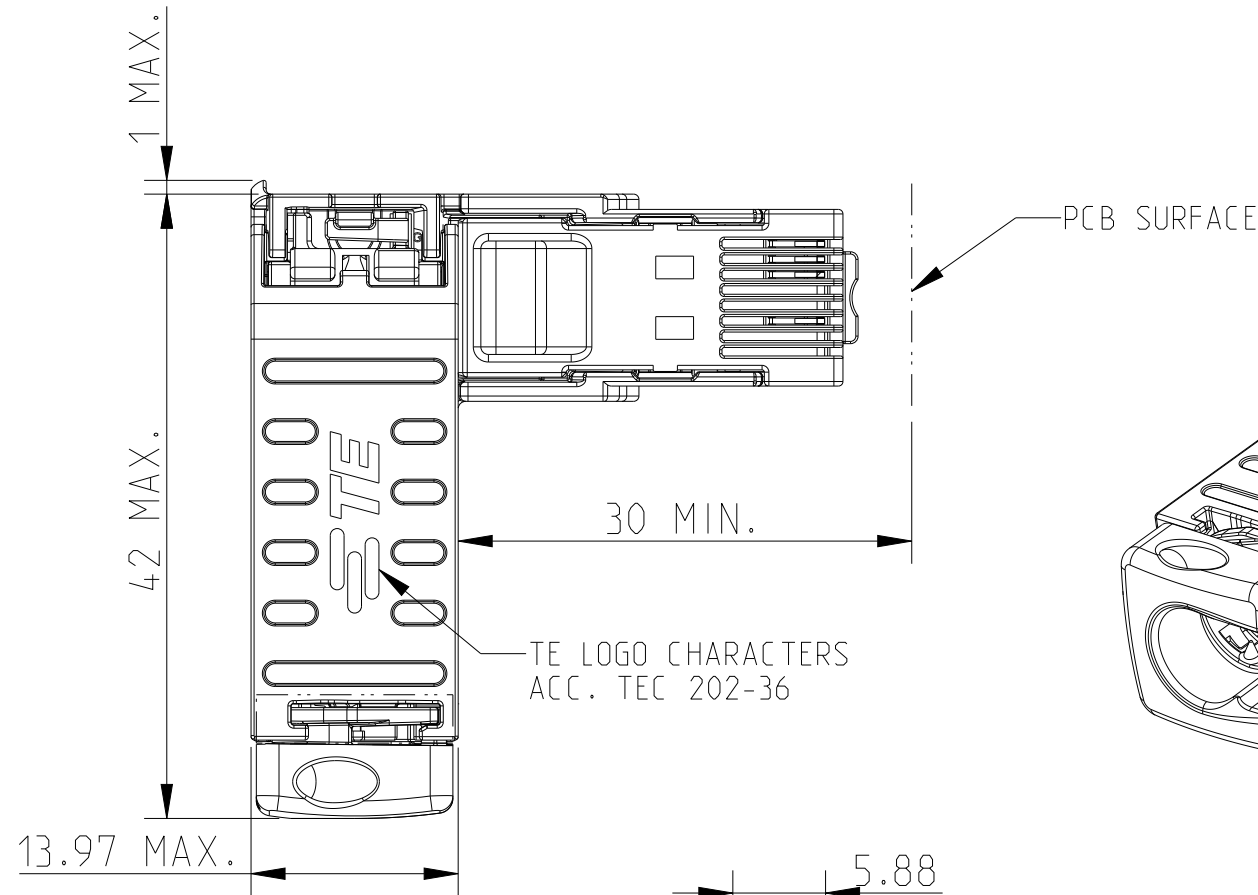
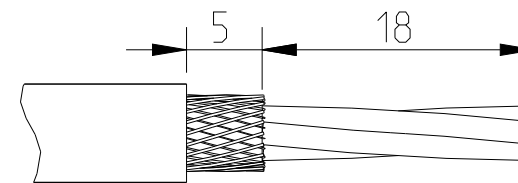

COLOR ALLOCATION OF TERMINAL WIRE TO RJ45 CONTACT:

CONTACT NO.	WIRE COLOR
1	YELLOW
2	ORANGE
3	WHITE
6	BLUE

1 MATES WITH RJ45 SOCKET ACC. TO IEC 60603-7:2008

2 VISUAL INSPECTION, OF THE DIE CAST PARTS, ACCORDING TO TE-SPEC. 101-85241

3 PROP 65 WARNING LABEL: SEE SHEET 2

50	10	1	CONNECTOR PACKED WITH INSTRUCTION SHEET
-3	-2	-1	DESCRIPTION
QTY REQD PER ASSY			PART LIST

THIS DRAWING IS A CONTROLLED DOCUMENT.

DIMENSIONS: mm	TOLERANCES UNLESS OTHERWISE SPECIFIED: 0 PLC ± 1 PLC ± 0.3 2 PLC ± 3 PLC ± 4 PLC ± ANGLES ±3°	DWN S SHARMA 15SEP2021 CHK N TAMMINEN 15SEP2021 APVD J DE BRUIJN 15SEP2021		
MATERIAL GD-Zn	FINISH Ni	PRODUCT SPEC 108-94864 APPLICATION SPEC 114-94770	NAME RJ45 FIELD INSTALLABLE CABLE CONN. 90	
		WEIGHT -	SIZE A3	CAGE CODE 00779
		CUSTOMER DRAWING	DRAWING NO. C-2383217	RESTRICTED TO -
		SCALE 2:1	SHEET 1 OF 2	REV A3

REVISIONS

P	LTR	DESCRIPTION	DATE	DWN	APVD
	-	SEE SHEET 1	-	-	-

NOTES: CONTINUATION FROM SHEET 1:

3 PROP 65 WARNING LABEL:

- THE WARNING LABEL ON THE PRODUCT OR LOWEST LEVEL PACKAGING.
- CHEMICAL NAME: ANTIMONY TRIOXIDE

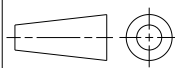

WARNING: This product can expose you to chemicals including ANTIMONY TRIOXIDE which is known to the state of California to cause cancer. For more information, visit www.P65Warnings.ca.gov.

THIS DRAWING IS A CONTROLLED DOCUMENT.		DWN S SHARMA 15SEP2021	TE TE Connectivity			
DIMENSIONS: mm		CHK N TAMMINEN 15SEP2021				
		TOLERANCES UNLESS OTHERWISE SPECIFIED:	NAME RJ45 FIELD INSTALLABLE CABLE CONN. 90			
		0 PLC ± 1 PLC ± 2 PLC ± 0.3 3 PLC ± 4 PLC ± ANGLES ±3°	APVD J DE BRUIJN 15SEP2021	PRODUCT SPEC 108-94864		
MATERIAL GD-Zn	FINISH Ni	APPLICATION SPEC 114-94770	SIZE A3	CAGE CODE 00779	DRAWING NO G-2383217	RESTRICTED TO -
CUSTOMER DRAWING			SCALE 2:1	SHEET 2 OF 2	REV A3	