

SCHEMATICS

mikromedia™

for Tiva™ C Series

We present you with a complete color schematics for mikromedia™ for Tiva™ C Series development board. We want you to know what your board is consisted of and how it actually works.

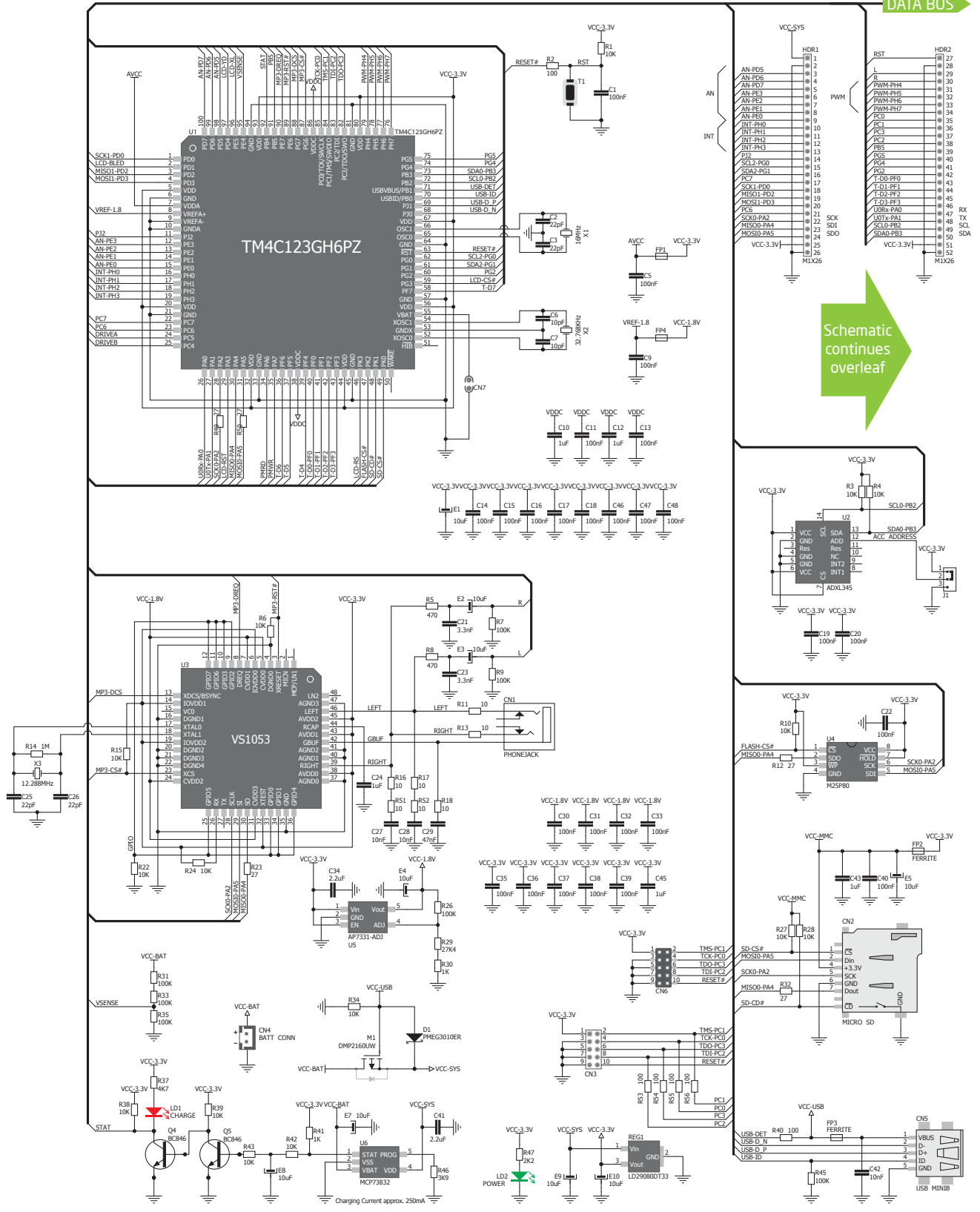

Schematic continues overleaf

Schematic continues overleaf



mikroelektronika for Tia C Series Schematics
Ver. 1.00

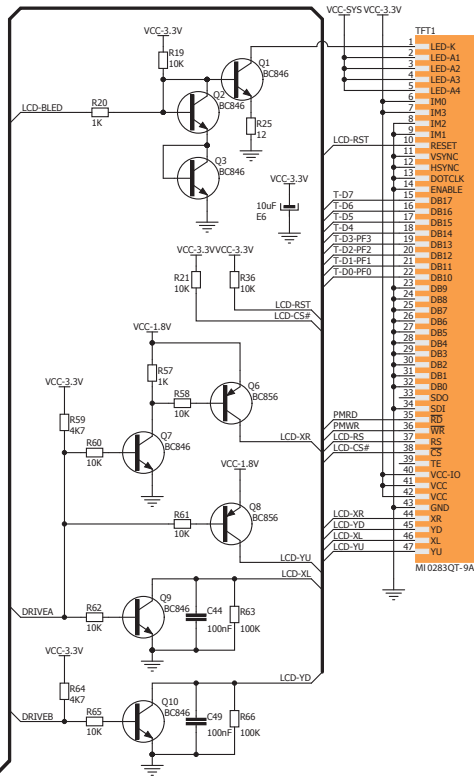

DATA BUS

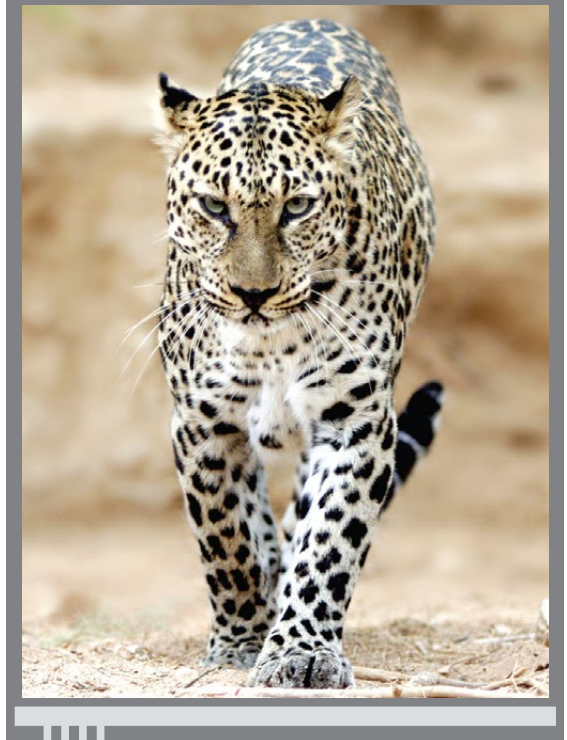

TFT 320x240 display with 262.144 colors

HW REV. 1.00

Copyright © 2014 MikroElektronika. All Rights Reserved.

MikroElektronika assumes no responsibility or liability for any errors or inaccuracies that may appear in the present document.

Specification and information contained in the present schematic are subject to change at any time without notice.