

注記 :
 NOTES:
 ① 材質 : TABLE 1参照
 MATERIAL : SEE TABLE 1
 ② 梱包仕様書、製品仕様書、嵌合相手はSHEET 2をご参照ください。
 PLEASE REFER TO SHEET 2 FOR PACKAGING SPECIFICATION,
 PRODUCT SPECIFICATION AND MATE WITH.
 ③ 本製品はコインなし品である。
 コインあり品は52670002-SD/PSD/000をご参照ください。
 THIS PRODUCT IS WITHOUT COIN.
 PLEASE REFER TO 52670002-SD/PSD/000 FOR WITH COIN PRODUCT.
 ④ 発注番号 : ORDER NO.
 22035**5

極数
 CIRCUIT SIZE

38.5±0.3	35	39.9±0.3	ポリ袋 POLY BAG	5267NA	526715A	22035155	15
36±0.3	32.5	37.4±0.3			526714A	22035145	14
33.5±0.3	30	34.9±0.3			526713A	22035135	13
31±0.3	27.5	32.4±0.3			526712A	22035125	12
28.5±0.25	25	29.9±0.25			526711A	22035115	11
26±0.25	22.5	27.4±0.25			526710A	22035105	10
23.5±0.25	20	24.9±0.25			526709A	22035095	9
21±0.25	17.5	22.4±0.25			526708A	22035085	8
18.5±0.25	15	19.9±0.25			526708A	22035075	7
16±0.25	12.5	17.4±0.25			526706A	22035065	6
13.5±0.25	10	14.9±0.25	526705A	22035055	5		
11±0.25	7.5	12.4±0.25	526704A	22035045	4		
8.5±0.2	5	9.9±0.2	526703A	22035035	3		
6±0.2	2.5	7.4±0.2	526702A	22035025	2		
C	B	A	梱包形態 PACKAGING	シリーズ番号 SERIES NO.	ENG. NO.	④ 発注番号 ORDER NO.	極数 CIRCUIT SIZE

① TABLE 1

番号 NO.	部品 PART	材質 MATERIAL
①	ハウジング HOUSING	ポリアミド(PA), UL94V-0, 色: ナチュラル(白) POLYAMIDE(PA), UL94V-0, COLOR: NATURAL (WHITE)
②	ピン PIN	母材 BASE METAL
		めっき PLATING
		下地めっき UNDERPLATING
		黄銅 ($\phi 0.7$) BRASS ($\phi 0.7$)
		錫めっき : 3 MICROMETER MIN. TIN
		銅めっき : 1 MICROMETER MIN. COPPER (UNDERPLATING)

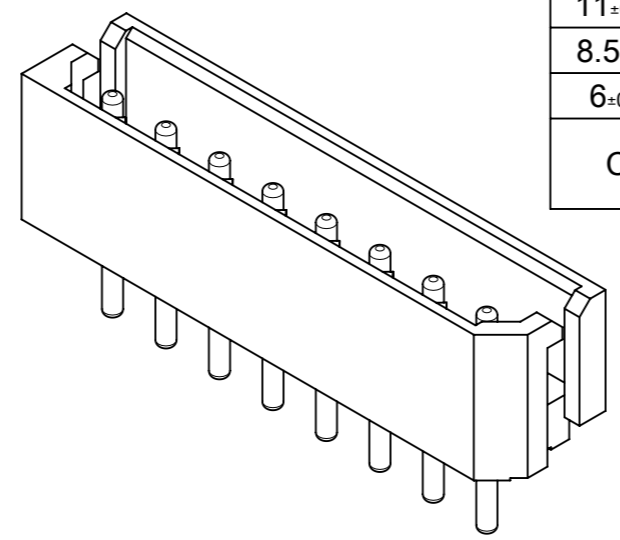

THIS DRAWING CONTAINS INFORMATION THAT IS PROPRIETARY TO MOLEX ELECTRONIC TECHNOLOGIES, LLC AND SHOULD NOT BE USED WITHOUT WRITTEN PERMISSION

DIMENSION UNITS	SCALE	CURRENT REV DESC:		
mm	NTS			
GENERAL TOLERANCES (UNLESS SPECIFIED)				
ANGULAR TOL	± 3.0°			
4 PLACES	±	EC NO: 727270	2022/11/30	
3 PLACES	±	DRWN: SOKUMURA01	2023/03/09	
2 PLACES	± 0.2	CHK'D: SAKIYAMA	2023/03/09	
1 PLACE	± 0.2	APPR: AIDA		
0 PLACES	±	INITIAL REVISION:		
DRAFT WHERE APPLICABLE MUST REMAIN WITHIN DIMENSIONS		DRWN: SUDAYGUNAGI	2019/06/18	
		APPR: KOMURAKAMI	2020/05/13	
THIRD ANGLE PROJECTION	DRAWING	SERIES	MATERIAL NUMBER	CUSTOMER
	A3-SIZE	5267	SEE CHART	GENERAL
		DOCUMENT NUMBER	DOC TYPE	DOC PART
		52670001-SD	PSD	000
		SHEET NUMBER		REVISION
		1 OF 2		B

△ 適用製品及び各種仕様書
 APPLICABLE PRODUCTS AND VARIOUS SPECIFICATIONS

梱包仕様書 PACKAGING SPECIFICATION	ORDER NO. 22035**5	SPECIFICATION NO. SPK-5267-001 PS 001
嵌合相手 MATE WITH	RECEPTACLE HOUSING	
シリーズ番号 SERIES NO.	5264N	
製品仕様書 PRODUCT SPECIFICATION	PS-5264-001 PS 001	

2-8極
2-8 CIRCUIT

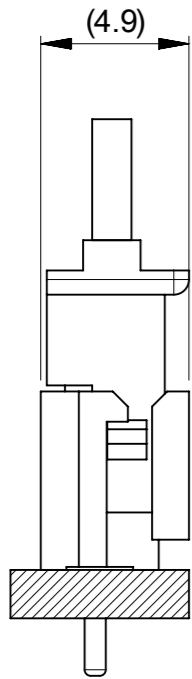

9-15極
9-15 CIRCUIT

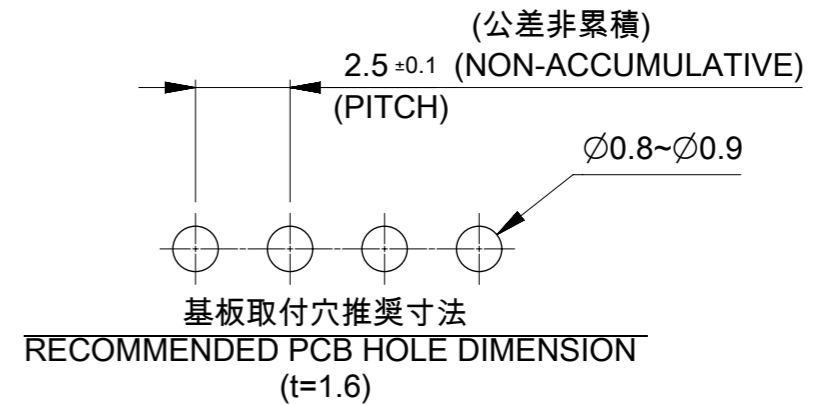
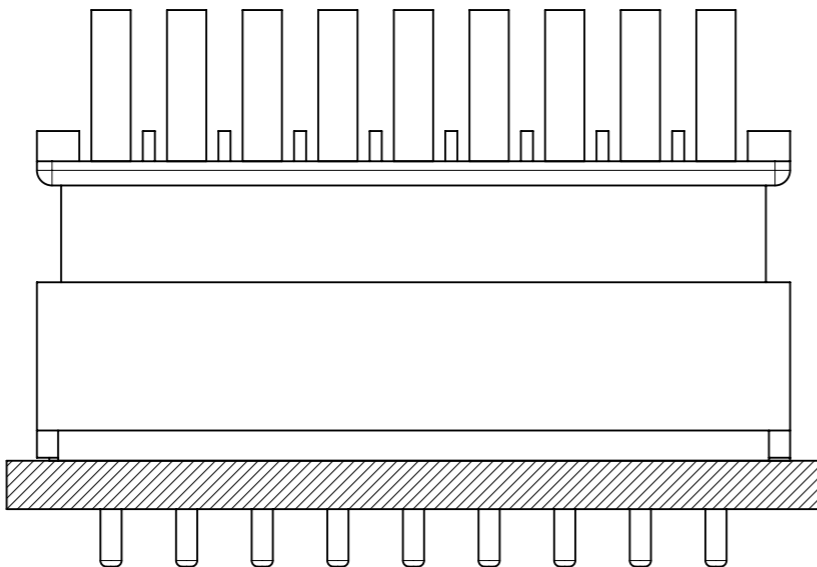
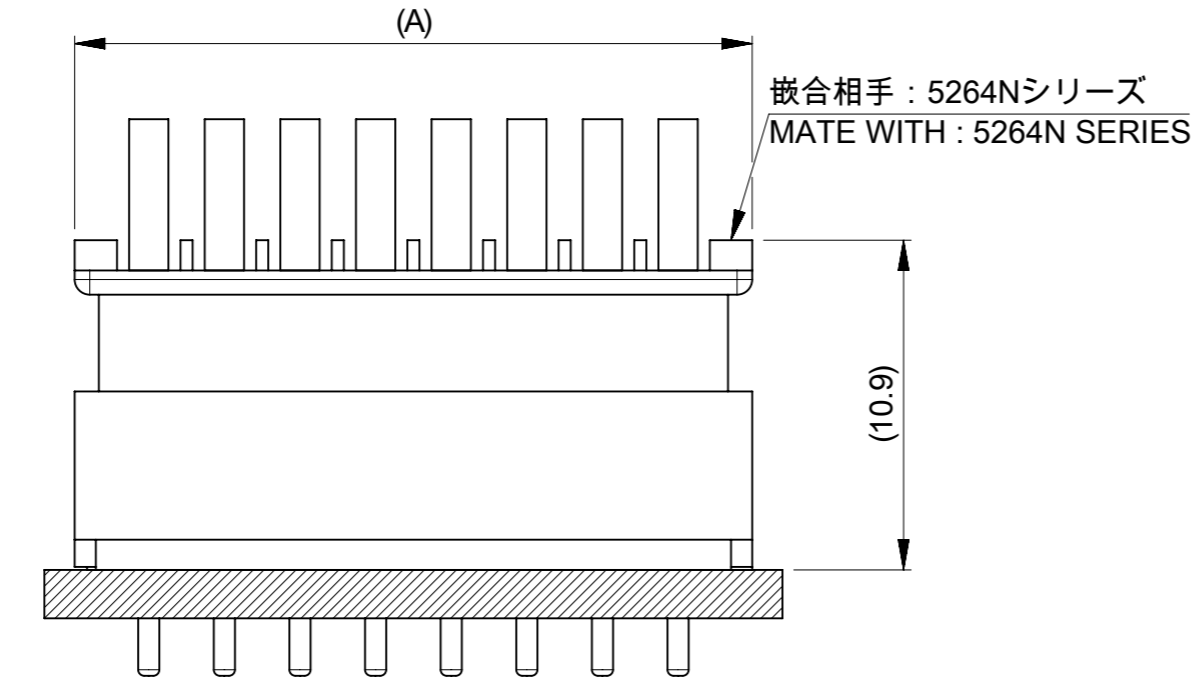
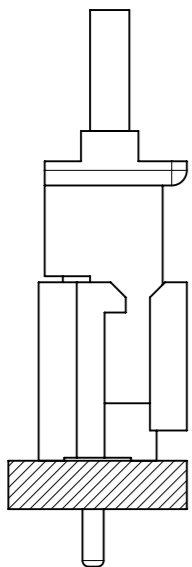

嵌合図
MATING CONNECTORS

THIS DRAWING CONTAINS INFORMATION THAT IS PROPRIETARY TO MOLEX ELECTRONIC TECHNOLOGIES, LLC AND SHOULD NOT BE USED WITHOUT WRITTEN PERMISSION										
DIMENSION UNITS mm	SCALE NTS	CURRENT REV DESC:								
GENERAL TOLERANCES (UNLESS SPECIFIED)		EC NO: 727270								
ANGULAR TOL ± 3.0 °	4 PLACES ±	DRWN: SOKUMURA01	2022/11/30	MINI-SPOX 2.5 W/B VERTICAL PLUG ASSEMBLY WITHOUT COIN COPPER UNDERPLATING						
3 PLACES ±	3 PLACES ±	CHK'D: SAKIYAMA	2023/03/09	PRODUCT CUSTOMER DRAWING						
2 PLACES ± 0.2	2 PLACES ±	APPR: AIDA	2023/03/09	DOCUMENT NUMBER						
1 PLACE ± 0.2	1 PLACE ±	INITIAL REVISION:		2019/06/18		52670001-SD		DOC TYPE	DOC PART	REVISION
0 PLACES ±	0 PLACES ±	DRWN: SUDAYGUNAGI	2020/05/13	2020/05/13		PSD		000	B	
DRAFT WHERE APPLICABLE MUST REMAIN WITHIN DIMENSIONS	THIRD ANGLE PROJECTION	DRAWING	SERIES	MATERIAL NUMBER	CUSTOMER	SHEET NUMBER				
		A3-SIZE	5267	SEE SHEET 1	GENERAL	2 OF 2				