

CATALOG NUMBER	MATERIAL NUMBER	CABLE RANGE	LENGTH "M"	N.P.T. FITTING SIZE	FORM SIZE	UL LISTED	CSA APPROVED
5630NM	1300990166	.312-.375 / 7.92-9.53	4.00±0.50 / 101.6±12.7	1/2	2	NO	NO
5631NM	1300990168	.375-.437 / 9.53-11.10	5.50±0.50 / 139.7±12.7				
5632NM	1300990170	.437-.500 / 11.10-12.70	5.50±0.50 / 139.7±12.7				
5633NM	1300990172	.437-.562 / 11.10-14.27	5.75±0.50 / 146.1±12.7	3/4	3	NO	NO
5634NM	1300990174	.500-.625 / 12.70-15.88	6.75±0.50 / 171.5±12.7				
5635NM	1300990176	.562-.687 / 14.27-17.45	6.75±0.50 / 171.5±12.7				
5640NM	1300990186	.625-.750 / 15.88-19.05	8.50±1.00 / 215.9±25.4	1	4	NO	NO
5636NM	1300990178	.562-.687 / 14.27-17.45	8.50±1.00 / 215.9±25.4				
5637NM	1300990180	.625-.750 / 15.88-19.05	8.50±1.00 / 215.9±25.4				
5638NM	1300990182	.750-.875 / 19.05-22.23	8.50±1.00 / 215.9±25.4				
5639NM	1300990184	.875-1.000 / 22.23-25.40	8.50±1.00 / 215.9±25.4				

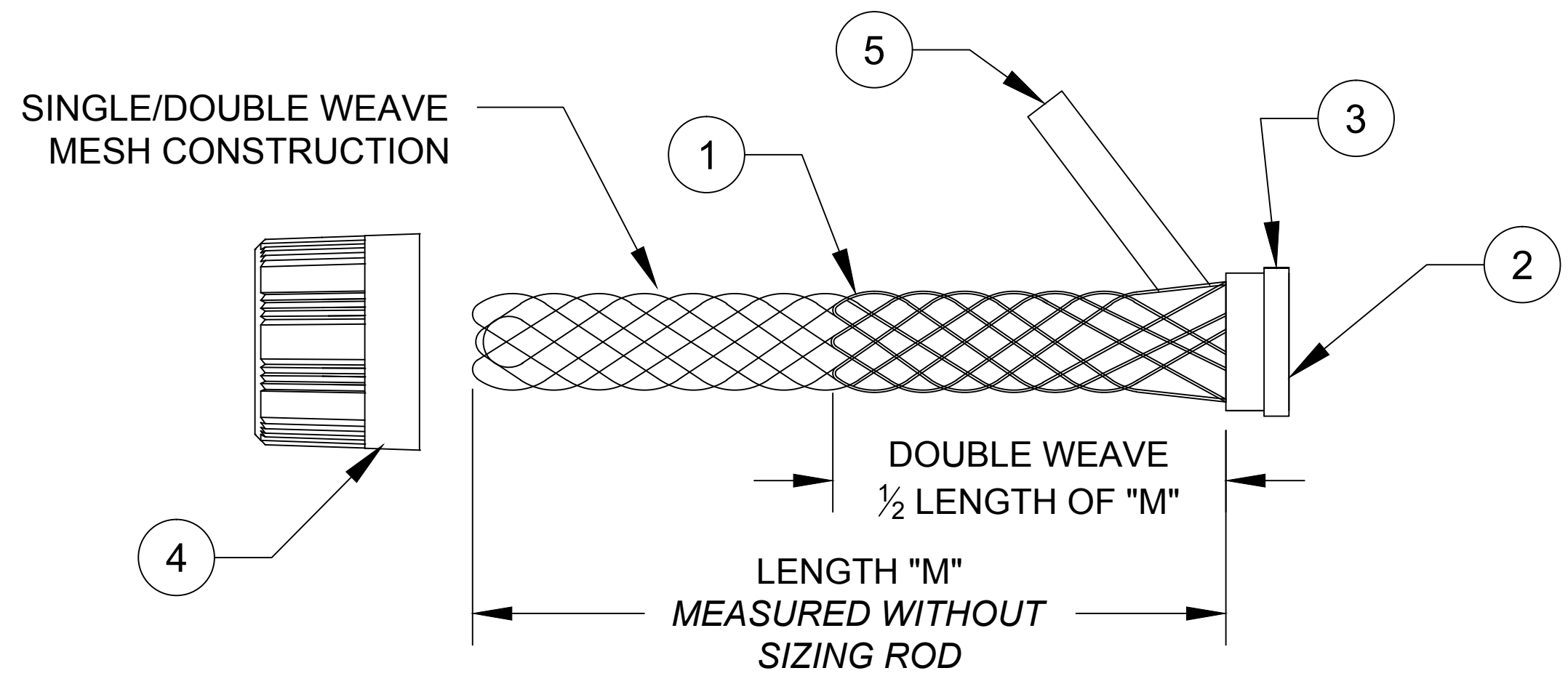
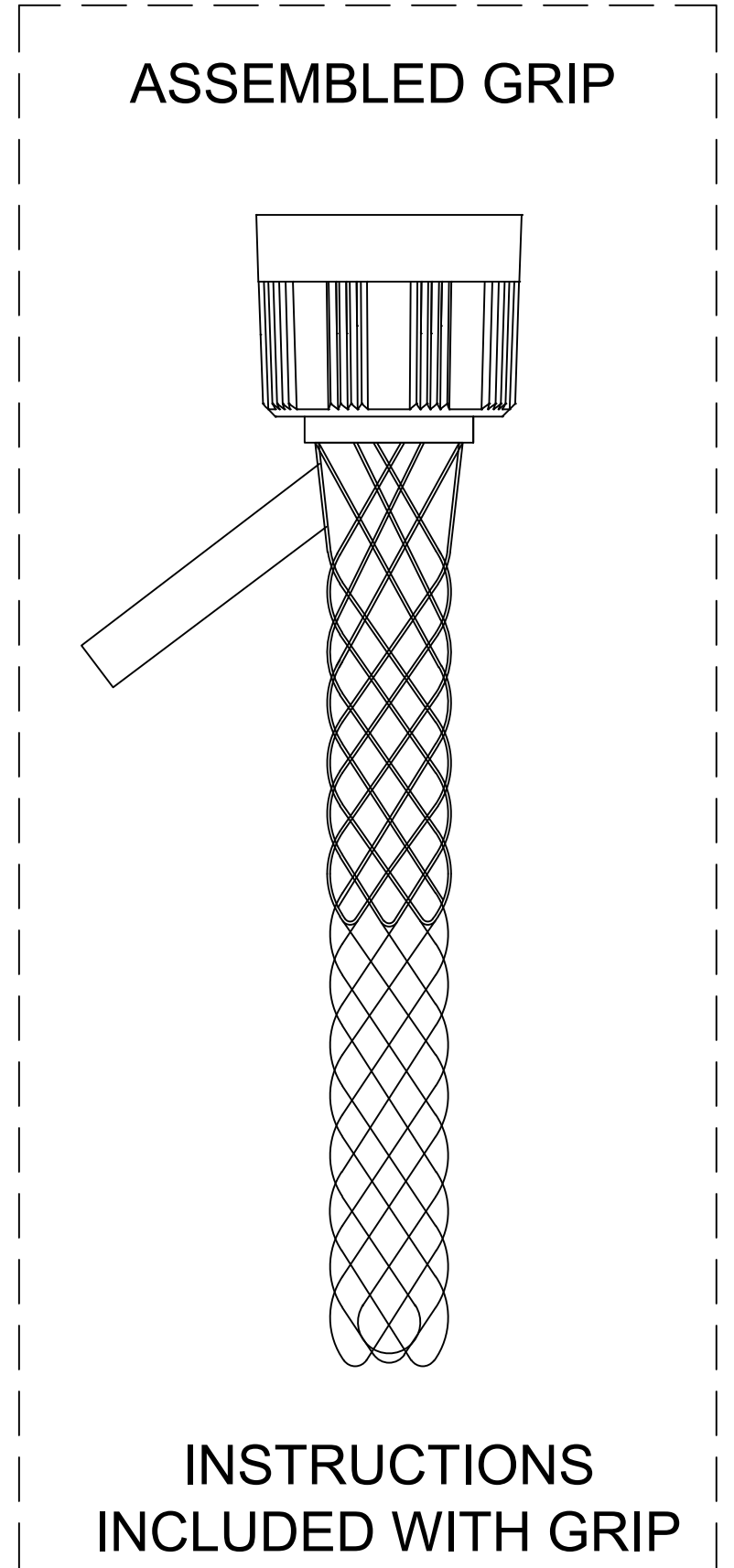

ITEM	DESCRIPTION	MATERIAL
1	WIRE MESH	POLYESTER (BLACK)
2	INNER RING	POLYETHYLENE TEREPHTHALATE (GRAY)
3	OUTER RING	POLYETHYLENE TEREPHTHALATE (GRAY)
4	COMPRESSION NUT	NYLON (YELLOW)
5	LABEL	MYLAR

RELEASE SALES DWG EC NO.: IFCG2014-2068 DRWN: HRUIZ01 2014/10/01 CH'KD: HKNEELAN 2014/10/01 APPR: JFMURPHY 2014/11/18	QUALITY SYMBOL	GENERAL TOLERANCES (UNLESS SPECIFIED)	DIMENSION STYLE INCH/MM	SCALE NTS	DESIGN UNITS INCH	THIRD ANGLE PROJECTION
	▽=0	4 PLACES ±---	mm INCH	DRAWN BY DATE	TITLE	MOLEX INCORPORATED
	∇=0	3 PLACES ±---		HRUIZ01 2014/10/01		
		2 PLACES ±.13 ±.010		CHECKED BY DATE		
		1 PLACE ±.25 ±.020	1 PLACE ±.25 ±.020	APPROVED BY DATE	JFMURPHY 2014/11/18	DOCUMENT NO. SD-130099-008
		ANGULAR ±1/2°	MATERIAL NO. SEE TABLE	THIS DRAWING CONTAINS INFORMATION THAT IS PROPRIETARY TO MOLEX INCORPORATED AND SHOULD NOT BE USED WITHOUT WRITTEN PERMISSION		
		DRAFT WHERE APPLICABLE MUST REMAIN WITHIN DIMENSIONS	SIZE C			