

LTC3888-1

8-Phase, Dual-Output Synchronous Buck Converter with Power System Management

DESCRIPTION

Demonstration circuit 2652A-B is an 8-phase dual-output, high efficiency, high density, synchronous buck converter with 7V to 14V input range. Each output can supply up to 120A maximum load current with 1V output. The demo board showcases the [LTC®3888-1](#), which is a PMBus-compliant dual loop 8-phase step-down DC/DC controller with digital power system management. The LTC3888-1 is designed to work with DrMOS devices that provide an output current sense and temperature monitor. Please see LTC3888-1's datasheet for more detailed information.

DC2652A-B powers up to default settings and produces power based on configuration resistors (or with the setting in its non-volatile memory) without the need for any serial bus communication. This allows easy evaluation of

the DC/DC converter. To fully explore the extensive power system management features of the part, download the GUI software LTpowerPlay™ onto your PC and use ADI's I²C/SMBus/PMBus dongle DC1613A to connect to the board. LTpowerPlay allows the user to reconfigure the part on the fly and store the configuration in EEPROM, view telemetry of voltage, current, temperature and fault status.

GUI Download

The software can be downloaded from: [LTpowerPlay](#)

For more details and instructions of LTpowerPlay, please refer to "LTpowerPlay Quick Start Procedure".

[Design files for this circuit board are available.](#)

All registered trademarks and trademarks are the property of their respective owners.

BOARD PHOTO

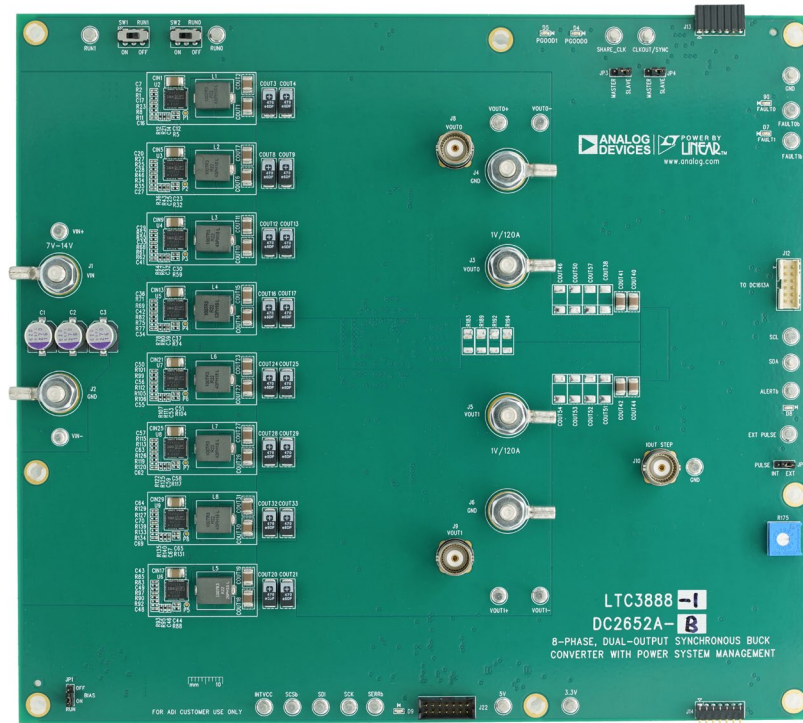

Figure 1. Dual-Output LTC3888-1/DC2652A-B Demo Circuit

DEMO MANUAL DC2652A-B

PERFORMANCE SUMMARY Specifications are at $T_A = 25^\circ\text{C}$

PARAMETER	CONDITIONS	UNITS
Input Voltage Range		7V to 14V
Output Voltage, V_{OUT0}	$V_{IN} = 7$ to 14V, $I_{OUT0} = 0\text{A}$ to 120A	0.3 to 1.8V, Default: 1.0V
Maximum Output Current, I_{OUT0}	$V_{IN} = 7$ to 14V, $V_{OUT0} = 0.3\text{V}$ to 1.8V	120A
Output Voltage, V_{OUT1}	$V_{IN} = 7$ to 14V, $I_{OUT1} = 0\text{A}$ to 120A	0.3 to 1.8V, Default: 1.0V
Maximum Output Current, I_{OUT1}	$V_{IN} = 7$ to 14V, $V_{OUT1} = 0.3\text{V}$ to 1.8V	120A
Typical Efficiency of V_{OUT0}	$V_{IN} = 12\text{V}$, $V_{OUT0} = 1.0\text{V}$, $I_{OUT0} = 120\text{A}$	91.6%
Typical Efficiency of V_{OUT1}	$V_{IN} = 12\text{V}$, $V_{OUT1} = 1.0\text{V}$, $I_{OUT1} = 120\text{A}$	91.6%
Default Switching Frequency		500kHz

QUICK START PROCEDURE

DC2652A-B is easy to set up to evaluate the performance of the LTC3888-1. Refer to Figure 2 for the proper measurement equipment setup and follow the procedure below.

1. With power off, connect the input power supply (7-14V) to VIN (J1) and GND (J2).
2. Connect the 1.0V output load (Initial load: no load) between VOUT0 (J3) and GND (J4).
3. Connect the 1.0V output load (Initial load: no load) between VOUT1 (J5) and GND (J6).
4. Connect the DMMs to the input and outputs. Set default jumper position:
JP1: ON
JP2: EXT
JP3: SLAVE
JP4: SLAVE
SW1: ON
SW2: ON
5. Turn on the input power supply and check for the proper output voltages. V_{OUT0} should be $1.0\text{V} \pm 0.5\%$ and V_{OUT1} should be $1.0\text{V} \pm 0.5\%$.
6. Once the proper output voltages are established, adjust the loads within the operating range and observe the output voltage regulation, ripple voltage and other parameters.

7. Connect the dongle and control the output voltages from the GUI. See “LTpowerPlay Quick Start Procedure” for details.

Note:

1. When measuring the efficiency, it is recommended to monitor the VIN, VOUT0 and VOUT1 at the locations close to the power stage. Here are examples:
 - (1) Monitor VIN across CIN9 and VOUT0 across COUT11 for VOUT0 efficiency measurement
 - (2) Monitor VIN across CIN25 and VOUT1 across COUT27 for VOUT1 efficiency measurement
2. When measuring the output or input voltage ripple, do not use the long ground lead on the oscilloscope probe. See Figure 3 for the proper scope probe technique. Short, stiff leads need to be soldered to the (+) and (-) terminals of an output capacitor. The probe’s ground ring needs to touch the (-) lead and the probe tip needs to touch the (+) lead.
3. When doing the load transient test, it is recommended to use a function generator to generate a pulse (~3% duty cycle with 10~100Hz frequency). Then applying this pulse to the EXT PULSE (E9) and GND (E10) turrets, the dynamic load circuit will work well to achieve desired load transient test by adjusting the amplitude, rising edge and falling edge of the pulse.

QUICK START PROCEDURE

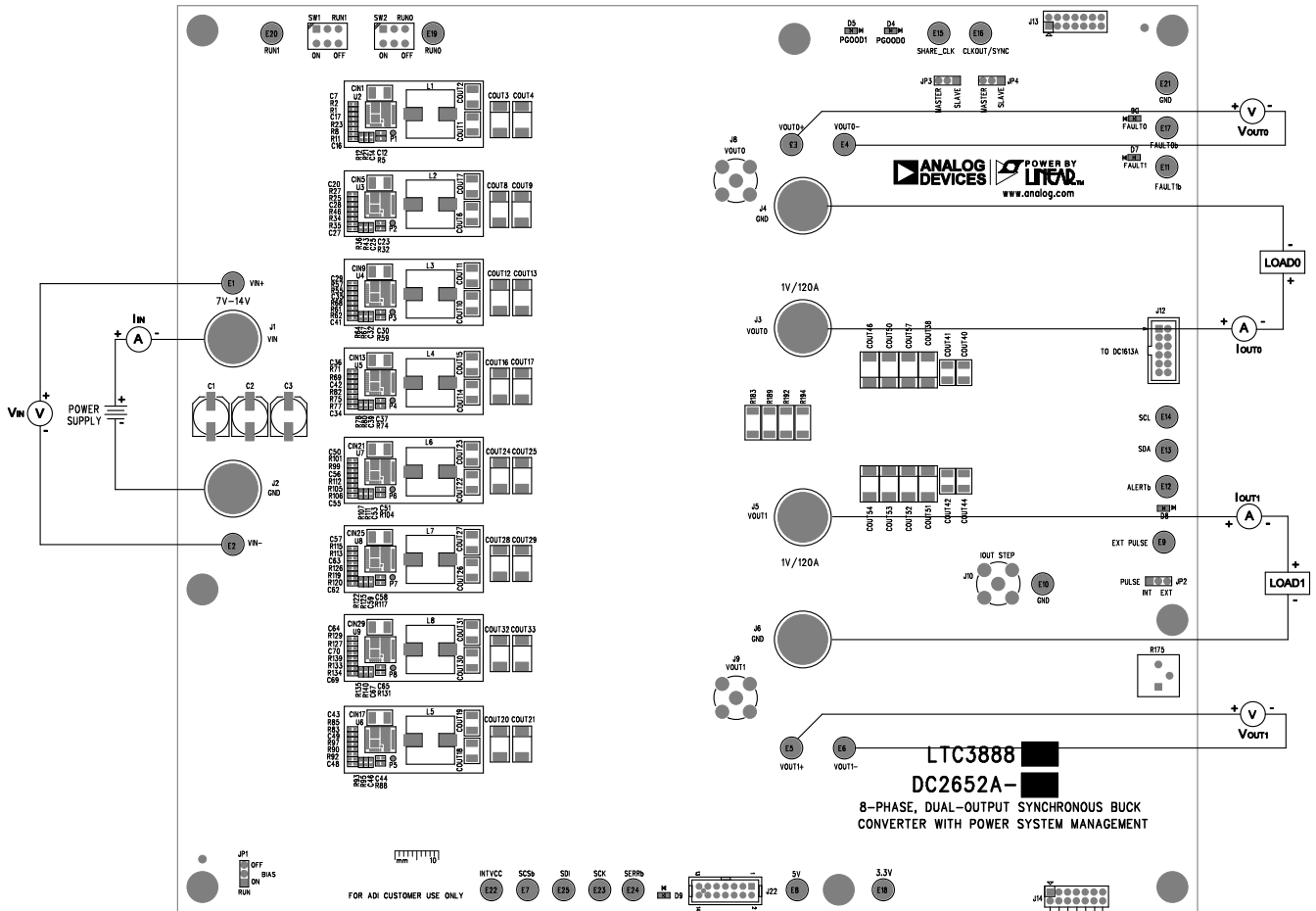

Figure 2. Proper Measurement Equipment Setup

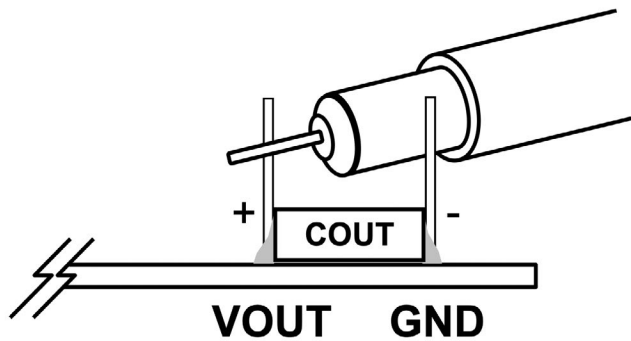

Figure 3. Measuring Output Voltage Ripple

DEMO MANUAL DC2652A-B

QUICK START PROCEDURE

Connecting a PC to DC2652A-B

You can use a PC to reconfigure the power management features of the LTC3888-1 such as: nominal V_{OUT} ,

margin set points, OV/UV limits, temperature fault limits, sequencing parameters, the fault log, fault responses, GPIOs and other functionalities. The DC1613A dongle may be plugged when V_{IN} is present.

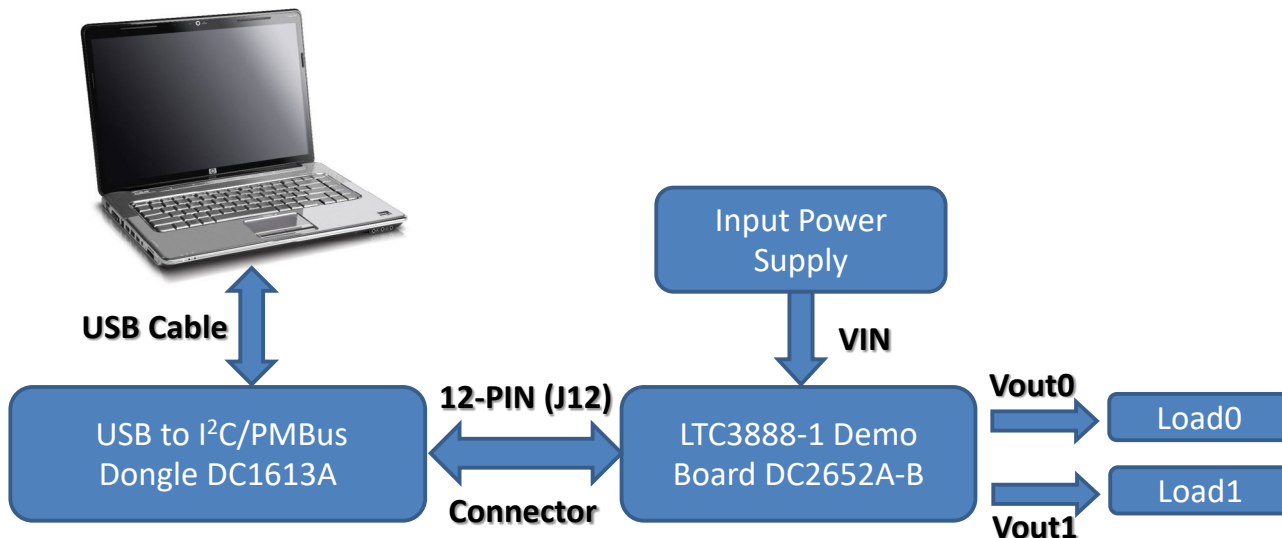

Figure 4. Demo setup with PC

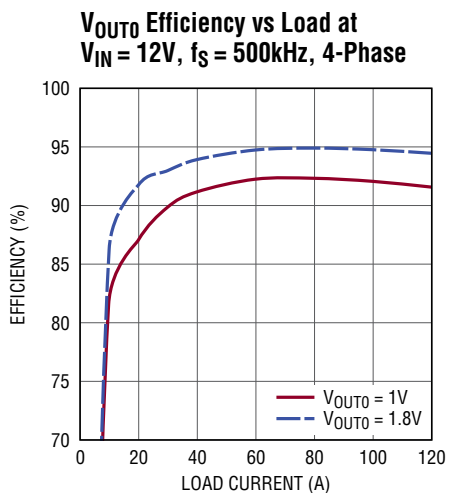

Figure 5. Efficiency vs. Load Current on V_{OUT0}

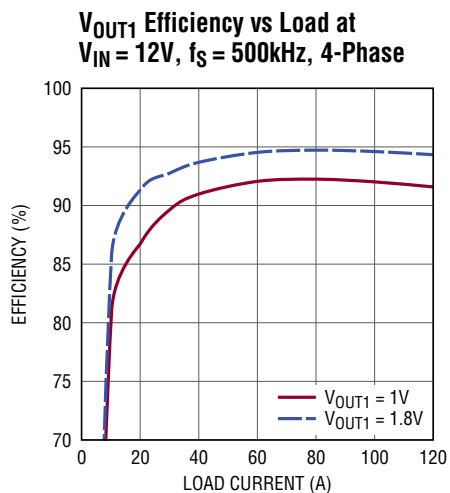

Figure 6. Efficiency vs. Load Current on V_{OUT1}

QUICK START PROCEDURE

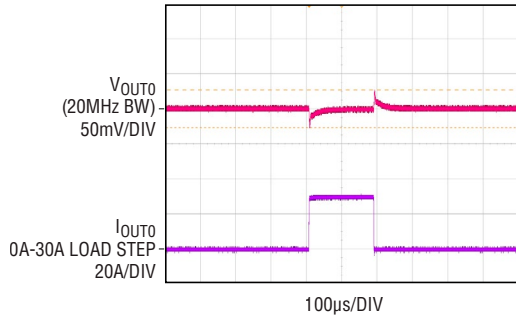

Figure 7. V_{OUT0} Load Transient Response at $V_{IN} = 12V$, $V_{OUT0} = 1.0V$

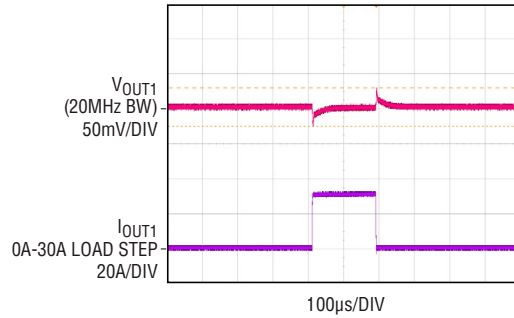

Figure 8. V_{OUT1} Load Transient Response at $V_{IN} = 12V$, $V_{OUT1} = 1.0V$

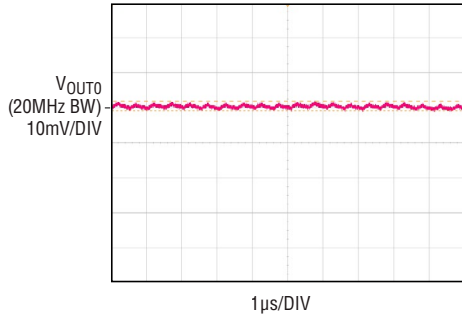

Figure 9. V_{OUT0} Voltage Ripple at $V_{IN} = 12V$, $V_{OUT0} = 1.0V$, $I_{OUT0} = 120A$

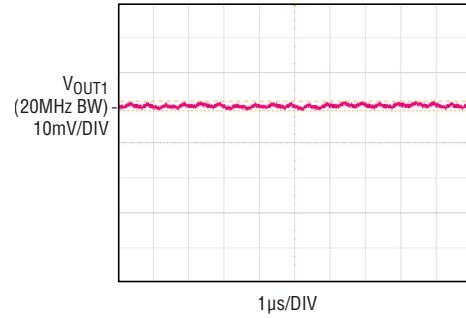

Figure 10. V_{OUT1} Voltage Ripple at $V_{IN} = 12V$, $V_{OUT1} = 1.0V$, $I_{OUT0} = 120A$

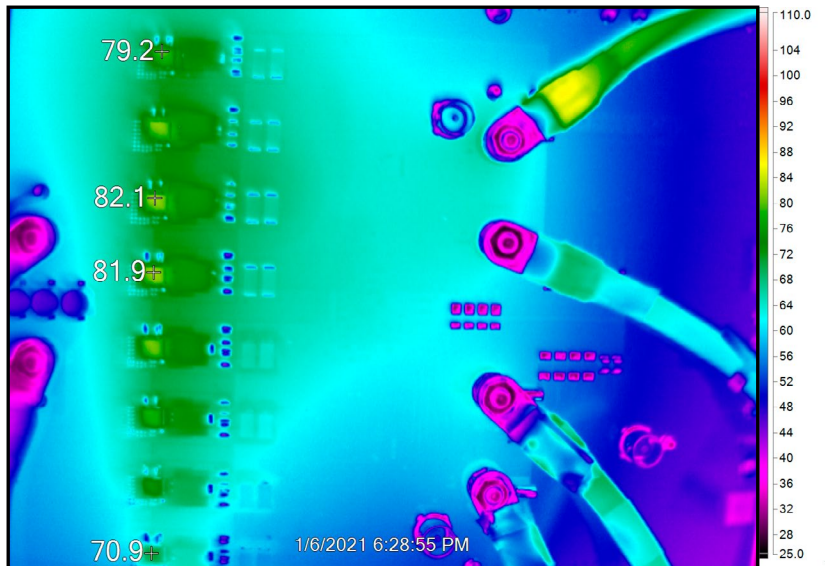

Figure 11. Thermal at $V_{IN} = 12V$, $V_{OUT0} = 1.0V$, $I_{OUT0} = 120A$, $V_{OUT1} = 1.0V$, $I_{OUT1} = 120A$, $T_A = 23^\circ C$, No Airflow

DEMO MANUAL DC2652A-B

LTPOWERPLAY SOFTWARE GUI

LTpowerPlay is a powerful Windows based development environment that supports Analog Devices power system management ICs and μ Modules, including LTM4675, LTM4676, LTM4677, LTM4678, LTM4680, LTM4700, LTC3880, LTC3882, LTC3883, LTC3884 and LTC3888-1. The software supports a variety of different tasks. You can use LTpowerPlay to evaluate Analog Devices ICs by connecting to a demo board system. LTpowerPlay can also be used in an offline mode (with no hardware present) in order to build a multichip configuration file that can be saved and reloaded at a later time. LTpowerPlay provides unprecedented diagnostic and debug features. It becomes a valuable diagnostic tool during board bring-up to program or tweak the power management scheme in

a system, or to diagnose power issues when bringing up rails. LTpowerPlay utilizes the DC1613A USB-to-I²C/SMBus/PMBus controller to communicate with one of many potential targets, including LTM4675, LTM4676, LTM4677, LTM4678, LTM4680, LTM4700, LTC3880, LTC3882, LTC3883, LTC3884 and LTC3888-1's demo system, or a customer board. The software also provides an automatic update feature to keep the software current with the latest set of device drivers and documentation. The LTpowerPlay software can be downloaded from: [LTpowerPlay](#)

To access technical support documents for ADI's Digital Power System Management Products, visit the LTpowerPlay Help menu.

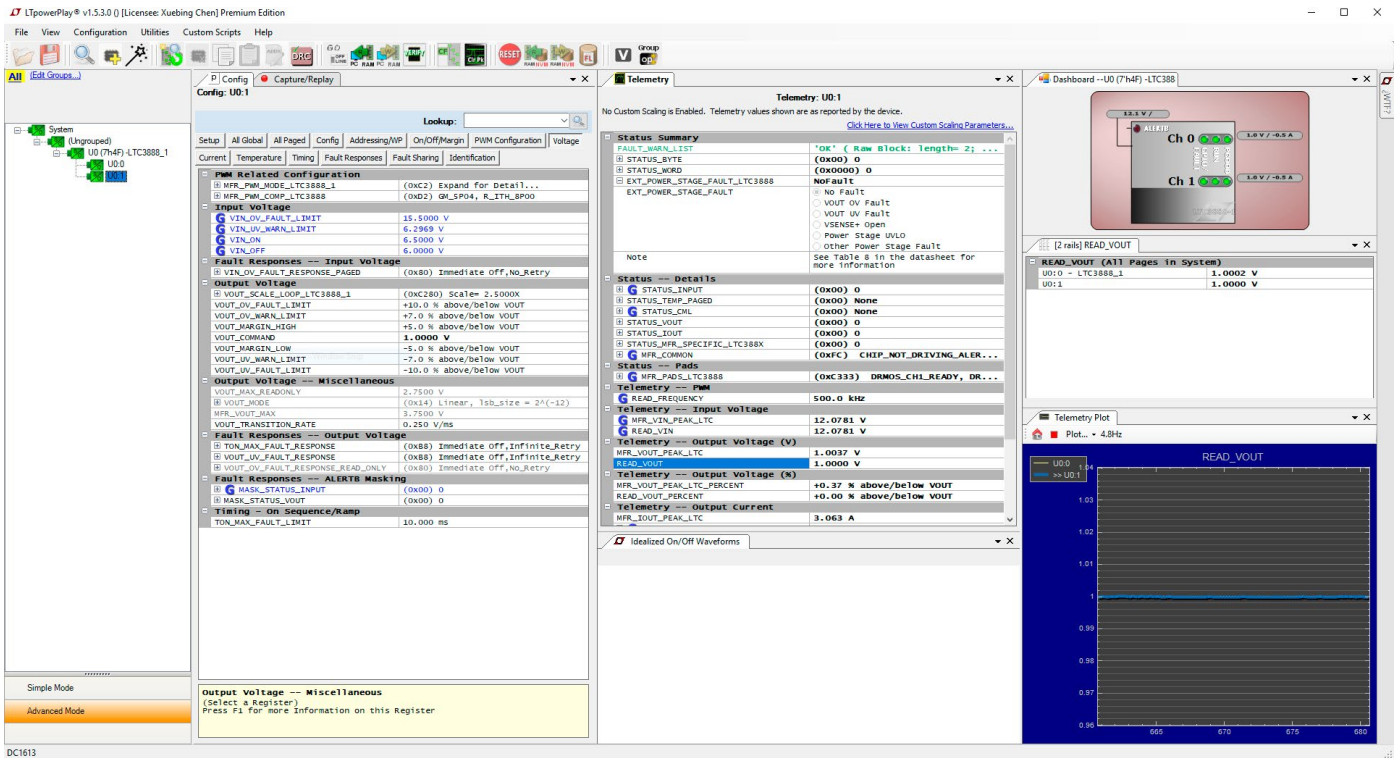
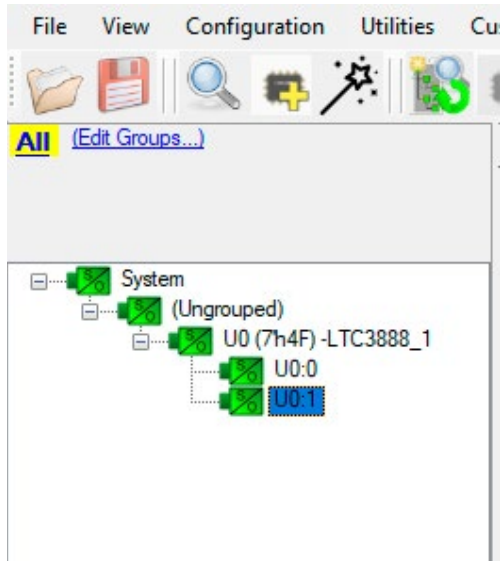

Figure 12. LTpowerPlay Main Interface

LTPOWERPLAY QUICK START PROCEDURE

The following procedure describes how to use LTpowerPlay to monitor and change the settings of LTC3888-1.

1. Download and install the [LTpowerPlay GUI](#):
2. Launch the LTpowerPlay GUI.
 - a. The GUI should automatically identify the DC2652A-B. The system tree on the left hand side should look like this:



- b. A green message box shows for a few seconds in the lower left hand corner, confirming that LTC3888-1 is communicating:

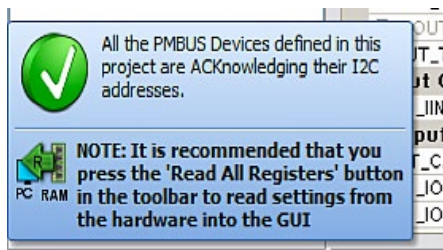

- c. In the Toolbar, click the R (RAM to PC) icon to read the RAM from the LTC3888-1. This reads the configuration from the RAM of LTC3888-1 and loads it into the GUI.



- d. To change the output voltage to a different value, such as 1.2V, enter 1.2 in the VOUT_COMMAND edit box, as shown below:

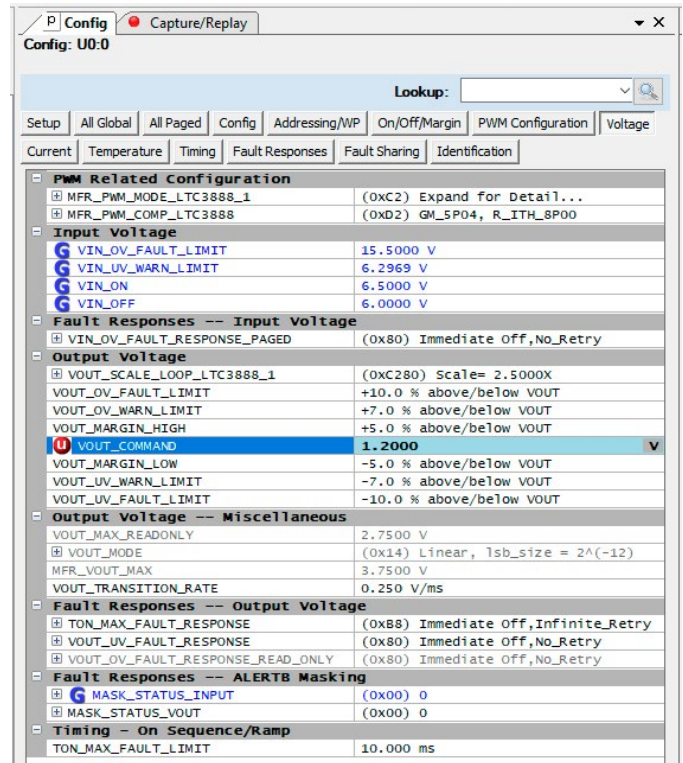

Then, click the W (PC to RAM) icon to write these register values to the LTC3888-1. After finishing this step, you will see the output voltage will change to 1.2V.



If the write is successful, you will see the following message:



- e. You can save the changes into the NVM. In the tool bar, click RAM to NVM button, as follows:



- f. Save the demo board configuration to a (*.proj) file. Click the Save icon and save the file.

DEMO MANUAL DC2652A-B

PARTS LIST

ITEM	QTY	REFERENCE	PART DESCRIPTION	MANUFACTURER/PART NUMBER
Required Circuit Components				
1	6	C1, C2, C3, C4, C5, C6	CAP, 270uF, ALUM, 16V, 20%, SMD 8x11.9mm, E12	PANASONIC/16SVPC270M
2	18	COUT1, COUT2, COUT6, COUT7, COUT10, COUT11, COUT14, COUT15, COUT18, COUT19, COUT22, COUT23, COUT26, COUT27, COUT30, COUT31, COUT64, COUT65	CAP, 100uF, X5R, 6.3V, 20%, 1210	AVX/12106D107MAT2A
3	32	CIN1, CIN2, CIN3, CIN4, CIN5, CIN6, CIN7, CIN8, CIN9, CIN10, CIN11, CIN12, CIN13, CIN14, CIN15, CIN16, CIN17, CIN18, CIN19, CIN20, CIN21, CIN22, CIN23, CIN24, CIN25, CIN26, CIN27, CIN28, CIN29, CIN30, CIN31, CIN32	CAP, 22uF, X7R, 25V, 10%, 1210	AVX/12103C226KAT2A
4	16	COUT3, COUT4, COUT8, COUT9, COUT12, COUT13, COUT16, COUT17, COUT20, COUT21, COUT24, COUT25, COUT28, COUT29, COUT32, COUT33	CAP, 470uF, TANT, POSCAP, 2.5V, 20%, 7343, TPF Series	PANASONIC/ETPF470M5H
5	16	C7, C16, C20, C27, C29, C34, C36, C41, C43, C48, C50, C55, C57, C62, C64, C69	CAP, 0.47uF, X5R, 10V, 10%, 0402	AVX/0402ZD474KAT2A
6	1	C8	CAP, 4.7uF, X5R, 16V, 20%, 0603	MURATA/GRM188R61C475MAAJD
7	1	C9	CAP, 1uF, X7R, 16V, 20%, 0603	AVX/0603YC105MAT2A
8	1	C10	CAP, 2.2uF, X5R, 16V, 10%, 0603	KEMET/C0603C225K4PAC7867
9	2	C11, C108	CAP, 2.2uF, X5R, 16V, 10%, 0805	AVX/0805YD225KAT2A
10	16	C12, C14, C23, C25, C30, C32, C37, C39, C44, C46, C51, C53, C58, C59, C65, C67	CAP, 4.7uF, JB, 10V, 20%, 0402	TDK/C1005JB1A475M050BC
11	8	C17, C28, C35, C42, C49, C56, C63, C70	CAP, 330pF, X7R, 50V, 10%, 0402	AVX/04025C331KAT2A
12	2	C18, C19	CAP, 3300pF, X7R, 50V, 10%, 0603	AVX/06035C332KAT2A
13	2	C21, C22	CAP, 330pF, X7R, 50V, 10%, 0603	KEMET/C0603S331K5RAC7867
14	3	CIN33, CIN34, COUT67	CAP, 10uF, X7R, 16V, 10%, 1210	AVX/1210YC106KAT2A
15	1	COUT66	CAP, 4.7uF, X5R, 16V, 20%, 1210	AVX/1210YD475MAT2A
16	2	C110, C113	CAP, 1uF, X7R, 50V, 10%, 0805	MURATA/GRM21BR71H105KA12L
17	1	C111	CAP, 4.7uF, X5R, 16V, 10%, 0603	AVX/0603YD475KAT2A
18	1	C112	CAP, 0.1uF, X7R, 16V, 10%, 0603	AVX/0603YC104KAT2A

PARTS LIST

ITEM	QTY	REFERENCE	PART DESCRIPTION	MANUFACTURER/PART NUMBER
19	1	C114	CAP., 5.6pF, COG/NPO, 50V, +/-0.25pF, 0603	AVX/06035A5R6CAT2A
20	1	C116	CAP., 100pF, COG/NPO, 25V, 5%, 0603	AVX/06033A101JAT2A
21	1	D1	DIODE, SCHOTTKY, 200V, 1A, PowerDI-123, AEC-Q101	DIODES INC./DFLS1200-7
22	8	L1, L2, L3, L4, L5, L6, L7, L8	IND., 215nH, PWR, FERRITE, 10%, 61A, 0.29mOHM, 10.4x8.0mm SMD	EATON/FP1007R3-R22-R
23	1	L9	IND., 4.7uH, PWR, 20%, 5.9A, 40mOhms, 5.48x5.28mm SMD, XAL5030, AEC-Q200	COILCRAFT/XAL5030-472MEB
24	1	R3	RES., 1 OHM, 5%, 1/10W, 0603, AEC-Q200	VISHAY/CRCW06031R00JNEA
25	3	R9, R10, R18	RES., 1k OHM, 1%, 1/10W, 0603, AEC-Q200	NIC/NRC06F1001TRF
26	7	R15, R17, R48, R49, R51, R54, R244	RES., 10k OHMS, 1%, 1/10W, 0603, AEC-Q200	KOA SPEER/RK73H1JTDD1002F
27	1	R16	RES., 4.99k OHMS, 1%, 1/10W, 0603, AEC-Q200	NIC/NRC06F4991TRF
28	8	R23, R46, R68, R82, R97, R112, R126, R139	RES., 10k OHMS, 1%, 1/16W, 0402, AEC-Q200	NIC/NRC04F1002TRF
29	1	R41	RES., 18.7k OHMS, 1%, 1/10W, 0603, AEC-Q200	NIC/NRC06F1872TRF
30	1	R53	RES., 2k OHMS, 1%, 1/10W, 0603, AEC-Q200	KOA SPEER/RK73H1JTDD2001F
31	4	R89, R98, R234, R235	RES., 10 OHMS, 1%, 1/10W, 0603	NIC/NRC06F10R0TRF
32	1	R250	RES., 2 OHMS, 1%, 1/10W, 0603, AEC-Q200	VISHAY/CRCW06032R00FKEA
33	1	R251	RES., 100k OHMS, 1%, 1/10W, 0603, AEC-Q200	PANASONIC/ERJ3EKF1003V
34	1	R252	RES., 60.4k OHMS, 1%, 1/10W, 0603, AEC-Q200	PANASONIC/ERJ3EKF6042V
35	1	R253	RES., 619k OHMS, 1%, 1/10W, 0603, AEC-Q200	NIC/NRC06F6193TRF
36	1	R255	RES., 200k OHMS, 1%, 1/10W, 0603	NIC/NRC06F2003TRF
37	1	R256	RES., 84.5k OHMS, 1%, 1/10W, 0603, AEC-Q200	NIC/NRC06F8452TRF
38	2	R277, R284	RES., 31.6k OHMS, 1%, 1/10W, 0603	YAGEO/RC0603FR-0731K6L
39	2	R278, R285	RES., 21k OHMS, 1%, 1/10W, 0603	ROHM/MCR03EZPF2102
40	1	U1	IC, 8-Phase, Dual Output Synch. Buck Cvrtr, QFN-52 (UHG)	ANALOG DEVICES/LTC3888UHG-1#PBF
41	8	U2, U3, U4, U5, U6, U7, U8, U9	IC, Powerstage Gate Driver, DrMOS, PQFN 5mmX6mm, 70A	INFINEON/TDA21470AUMA1
42	1	U22	IC, 1A SYNC. STEP-DOWN CONVERTER, DFN-14	ANALOG DEVICES/LTC3646EDE-1#PBF

Additional Demo Board Circuit Components

1	0	C13, C24, C31, C38, C45, C52, C60, C66	CAP., OPTION, 0402	
2	0	C15, C26, C33, C40, C47, C54, C61, C68, C115, C119, C121, C122	CAP., OPTION, 0603	
3	0	COU38, COU45, COU46, COU50, COU51, COU52, COU53, COU54, COU57, COU58, COU59, COU62	CAP., OPTION, 7343	

DEMO MANUAL DC2652A-B

PARTS LIST

ITEM	QTY	REFERENCE	PART DESCRIPTION	MANUFACTURER/PART NUMBER
4	4	COUT39, COUT60, COUT61, COUT63	CAP., 470uF, TANT, POSCAP, 2.5V, 20%, 7343, TPF Series	PANASONIC/ETPF470M5H
5	10	COUT40, COUT41, COUT42, COUT44, COUT47, COUT48, COUT55, COUT56, C84, C85	CAP., 100uF, X5R, 6.3V, 20%, 1210	AVX/12106D107MAT2A
6	2	COUT43, COUT49	CAP., 1uF, X7R, 16V, 20%, 0603	AVX/0603YC105MAT2A
7	4	C102, C103, C105, C106	CAP., 10uF, X5R, 10V, 10%, 0603	AVX/0603ZD106KAT2A
8	2	C104, C107	CAP., 0.01uF, C0G, 25V, 5%, 0603	AVX/06033A103JAT2A
9	1	C86	CAP., 0.1uF, X7R, 50V, 10%, 0603	AVX/06035C104KAT2A
10	2	C87, C89	CAP., 1uF, X7R, 16V, 20%, 0603	AVX/0603YC105MAT2A
11	1	C88	CAP., 150pF, C0G, 25V, 10%, 0603	AVX/06033A151KAT2A
12	1	C90	CAP., 0.1uF, X7R, 50V, 10%, 0603	AVX/06035C104KAT2A
13	2	C91, C92	CAP., 0.01uF, C0G, 25V, 5%, 0603	AVX/06033A103JAT2A
14	6	C99, C100, C101, C117, C118, C120	CAP., 0.1uF, X7R, 50V, 10%, 0603	AVX/06035C104KAT2A
15	0	D2, D3	DIODE, OPTION, SOD-323	
16	2	D4, D5	LED, GREEN, WATER CLEAR, 0603	WURTH/150060GS75000
17	3	D6, D7, D8	LED, SUPER RED, WATERCLEAR, 0603	WURTH/150060SS75000
18	1	D9	LED, SUPER RED, WATERCLEAR, 0603	WURTH/150060SS75000
19	6	D10, D11, D12, D13, D14, D15	DIODE, SCHOTTKY, 20V, 0.5A, SOD-882, LEADLESS	NEXPERIA/PMEG2005AEL, 315
20	2	Q1, Q2	XSTR., MOSFET, N-CH, 40V, 14A, DPAK (TO-252)	VISHAY/SUD50N04-8M8P-4GE3
21	4	Q3, Q4, Q5, Q6	XSTR., MOSFET, P-CH, 30V, 3.5A, SOT23-3, AEC-Q101	DIODES INC./DMP3130L-7
22	2	Q7, Q8	XSTR., MOSFET, N-CH, 60V, 210mA, SOT-23	DIODES INC./2N7002-13-F
23	1	Q9	XSTR., MOSFET, P-CH, 30V, 3.5A, SOT23-3, AEC-Q101	DIODES INC./DMP3130L-7
24	64	R1, R2, R5, R6, R8, R12, R21, R22, R25, R27, R29, R32, R34, R36, R43, R50, R55, R57, R58, R59, R61, R64, R66, R67, R69, R71, R72, R74, R75, R78, R80, R81, R83, R85, R86, R88, R90, R93, R95, R96, R99, R101, R102, R104, R105, R107, R110, R111, R113, R115, R116, R117, R119, R122, R124, R125, R127, R129, R130, R131, R133, R135, R138, R140	RES., 0 OHM, 1/16W, 0402	NIC/NRC04ZOTRF

PARTS LIST

ITEM	QTY	REFERENCE	PART DESCRIPTION	MANUFACTURER/PART NUMBER
25	0	R4, R7, R11, R26, R33, R35, R56, R60, R62, R70, R73, R77, R84, R87, R92, R100, R103, R106, R114, R118, R120, R128, R132, R134	RES., OPTION, 0402	
26	14	R28, R30, R166, R198, R200, R202, R203, R257, R274, R275, R280, R282, R287, R289	RES., 0 OHM, 1/10W, 0603, AEC-Q200	NIC/NRC06ZOTRF
27	0	R37, R38, R39, R40, R42, R44, R47, R52, R179, R180, R181, R182, R187, R188, R191, R196, R197, R199, R201, R204, R210, R211, R212, R213, R268, R269, R276, R279, R281, R283, R286, R288, R290, R291, R292	RES., OPTION, 0603	
28	0	R162, R163, R183, R184, R189, R190, R192, R193, R194, R195	RES., OPTION, 2010	
29	1	R164	RES., 2 OHMS, 1%, 1/10W, 0603, AEC-Q200	VISHAY/CRCW06032R00FKEA
30	1	R165	RES., 3.3 OHMS, 1%, 1/10W, 0603, AEC-Q200	VISHAY/CRCW06033R30FKEA
31	1	R167	RES., 154k OHMS, 1%, 1/10W, 0603, AEC-Q200	NIC/NRC06F1543TRF
32	1	R168	RES., 1M OHM, 1%, 1/10W, 0603, AEC-Q200	NIC/NRC06F1004TRF
33	2	R169, R170	RES., 20k OHMS, 1%, 1/10W, 0603	NIC/NRC06F2002TRF
34	1	R171	RES., 681k OHMS, 1%, 1/10W, 0603, AEC-Q200	NIC/NRC06F6813TRF
35	2	R172, R218	RES., 10k OHMS, 1%, 1/10W, 0603, AEC-Q200	KOA SPEER/RK73H1JTTD1002F
36	1	R173	RES., 301 OHMS, 1%, 1/10W, 0603, AEC-Q200	NIC/NRC06F3010TRF
37	1	R174	RES., 82.5 OHMS, 1%, 1/10W, 0603, AEC-Q200	NIC/NRC06F82R5TRF
38	1	R175	RES., 5k OHMS, 10%, 1/2W, THT 3/8 SQ, 1-TURN, TOP ADJ., TRIMPOT	BOURNS/3386P-1-502LF
39	0	R176	RES., OPTION, 2512	
40	1	R177	RES., 0.01 OHM, 1%, 1W, 2512, PWR, METAL, SENSE, AEC-Q200	VISHAY/WSL2512R0100FEA
41	1	R178	RES., 1.21k OHMS, 1%, 1/10W, 0603	PANASONIC/ERJ3EKF1211V
42	2	R185, R186	RES., 27.4 OHMS, 1%, 1W, 2512, AEC-Q200	PANASONIC/ERJ1TNF27R4U
43	2	R205, R206	RES., 10 OHMS, 1%, 1/10W, 0603	NIC/NRC06F10R0TRF
44	2	R207, R208	RES., 4.99k OHMS, 1%, 1/10W, 0603, AEC-Q200	NIC/NRC06F4991TRF

DEMO MANUAL DC2652A-B

PARTS LIST

ITEM	QTY	REFERENCE	PART DESCRIPTION	MANUFACTURER/PART NUMBER
45	0	R209	RES., OPTION, 1206	
46	5	R214, R215, R216, R217, R219	RES., 2k OHMS, 1%, 1/10W, 0603, AEC-Q200	KOA SPEER/RK73H1JTDD2001F
47	1	R220	RES., 15.8k OHMS, 1%, 1/10W, 0603, AEC-Q200	NIC/NRC06F1582TRF
48	1	R233	RES., 2k OHMS, 1%, 1/10W, 0603, AEC-Q200	KOA SPEER/RK73H1JTDD2001F
49	1	R258	RES., 0 OHM, 1/8W, 0805	VISHAY/CRCW08050000Z0EA
50	2	R242, R246	RES., 332k OHMS, 1%, 1/10W, 0603, AEC-Q200	NIC/NRC06F3323TRF
51	2	R243, R245	RES., 3.32k OHMS, 1%, 1/10W, 0603, AEC-Q200	PANASONIC/ERJ3EKF3321V
52	2	R262, R263	RES., 1 OHM, 1%, 1/8W, 0805, AEC-Q200	VISHAY/CRCW08051R00FKEA
53	7	R259, R260, R261, R264, R267, R272, R273	RES., 1 OHM, 5%, 1/10W, 0603, AEC-Q200	VISHAY/CRCW06031R00JNEA
54	3	R265, R266, R270	RES., 10k OHMS, 1%, 1/10W, 0603, AEC-Q200	KOA SPEER/RK73H1JTDD1002F
55	1	U13	OSC., 3.81Hz to 1MHz, 5pF, 90ppm, TSOT23-6	ANALOG DEVICES/LTC6992IS6-1#PBF
56	1	U14	IC, Single R to R In/Out Op Amp, TSOT23-5, 100V/us, 85MHz	ANALOG DEVICES/LT1803IS5#PBF
57	1	U15	IC, EEPROM, I2C, TSSOP-8, 2Kb (256 x 8), 400kHz	MICROCHIP/24LC024-I/ST
58	1	U18	IC, TRANSLATING TRANSCEIVER, XQFN-12	NXP/NTB0104GU12, 115
59	1	U19	IC, SWITCH QUAD SPST, TSSOP-16	ANALOG DEVICES/ADG711BRUZ
60	2	U20, U21	IC, 1.1A ADJ. SINGLE RESISTOR LDO, MSOP-8	ANALOG DEVICES/LT3080EMS8E-1#PBF
61	1	U23	IC, 4-BIT DUAL-SUPPLY BUS XCVR, TSSOP-16	TEXAS INSTRUMENTS/SN74AVC4T774PW
62	1	U24	IC, DUAL BUFFER GATE, SOT23-6	TEXAS INSTRUMENTS/SN74LVC2G34DBV
63	1	U25	IC, I2C BUS TO SPI BRIDGE, TSSOP-16	NXP/SC18IS602BIPW, 112

PARTS LIST

ITEM	QTY	REFERENCE	PART DESCRIPTION	MANUFACTURER/PART NUMBER
Hardware: For Demo Board Only				
1	4	XJP1, XJP2, XJP3, XJP4	CONN., SHUNT, FEMALE, 2 POS, 2mm	WURTH/60800213421
2	8	MP1, MP2, MP3, MP4, MP5, MP6, MP7, MP8	STANDOFF, NYLON, SNAP-ON, 0.50	WURTH/702935000
3	25	E1, E2, E3, E4, E5, E6, E7, E8, E9, E10, E11, E12, E13, E14, E15, E16, E17, E18, E19, E20, E21, E22, E23, E24, E25	TEST POINT, TURRET, 0.094 MTG. HOLE, PCB 0.062 THK	MILL-MAX/2501-2-00-80-00-00-07-0
4	6	J1, J2, J3, J4, J5, J6	STUD, FASTENER, #10-32	PENNINGENGINEERING/KFH-032-10ET
5	12	J1, J2, J3, J4, J5, J6	NUT, HEX, #10-32, STEEL, ZINC PLATE	KEYSTONE/4705
6	6	J1, J2, J3, J4, J5, J6	RING, LUG, #10, CRIMP, 16/14 AWG, NON-INSULATED, SOLDERLESS TERMINALS	KEYSTONE/8205
7	6	J1, J2, J3, J4, J5, J6	WASHER, FLAT, STEEL, ZINC PLATE, OD: 0.436 [11.1]	KEYSTONE/4703
8	4	JP1, JP2, JP3, JP4	CONN., HDR, MALE, 1x3, 2mm, VERT, ST, THT	WURTH/62000311121
9	3	J8, J9, J10	CONN., RF, BNC, RCPT, JACK, 5-PIN, ST, THT, 50 OHMS	AMPHENOL RF/112404
10	1	J12	CONN., HDR, SHROUDED, MALE, 2x6, 2mm, VERT, ST, THT	AMPHENOL/98414-G06-12ULF
11	1	J13	CONN., HDR, FEMALE, 2x7, 2mm, R/A THT	SOLUTIONS/NPPN072FJFN-RC
12	1	J14	CONN., HDR, MALE, 2x7, 2mm, R/A THT	MOLEX/0877601416
13	1	J22	CONN., HDR, SHROUDED, MALE, 2x7, 2mm, VERT, ST, THT	MOLEX/87831-1420
14	2	SW1, SW2	SWITCH, SLIDE, DPDT, 0.3A, 6VDC, PTH	C&K/JS202011CQN

DEMO MANUAL DC2652A-B

SCHEMATIC DIAGRAM

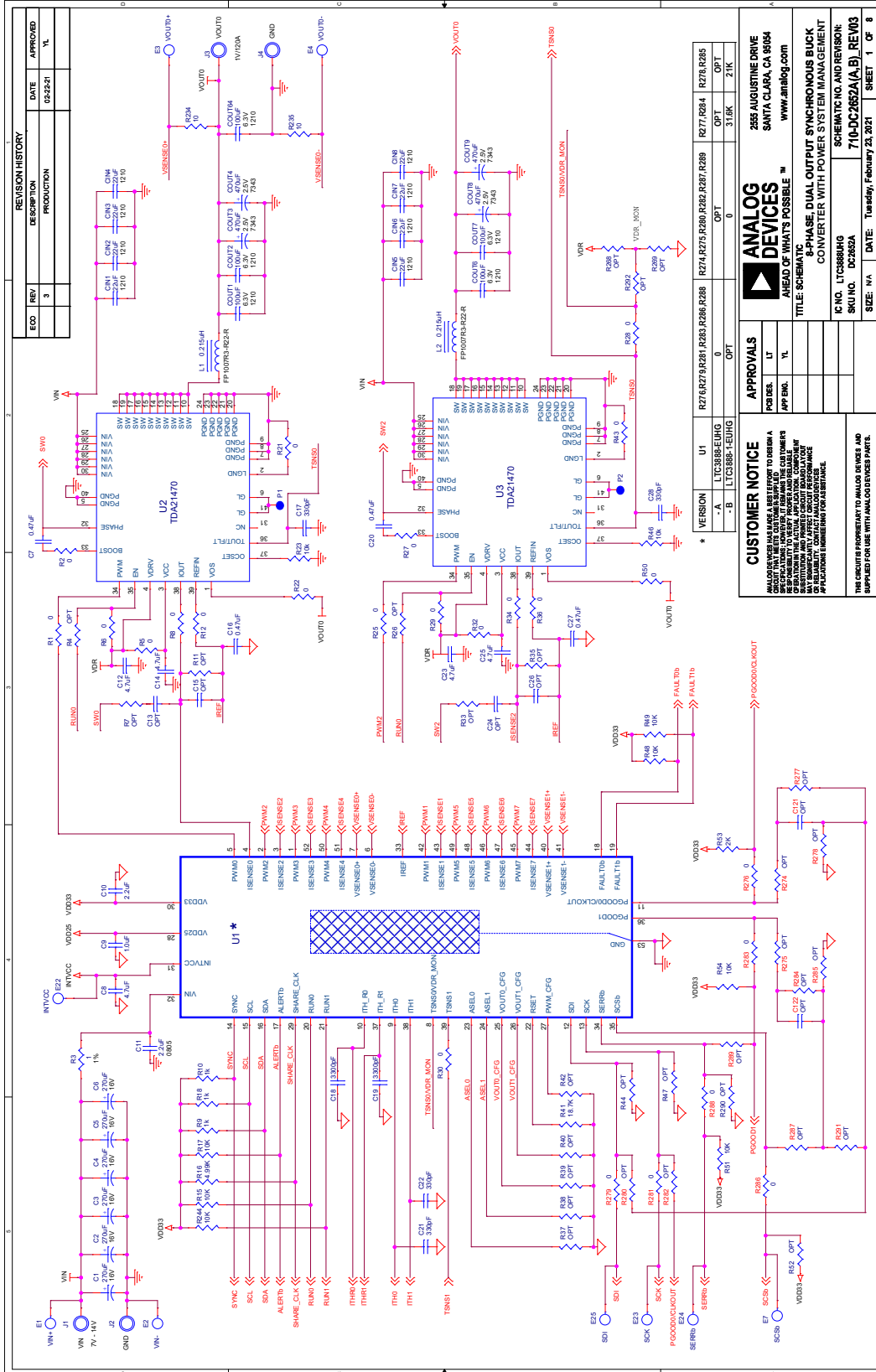

REVISION HISTORY			
ECO	REV	DESCRIPTION	APPROVED
	3	PRODUCTION	YL
		DATE	03/25/21

APPROVALS		VERSION		R274 R275 R280 R282 R297 R298		R277 R264 R278 R285			
DESIGN	UT	A	LTC3888-UG	0	OPT	0	OPT		
APP ENR	YL	-B	LTC3888-1-UG	0	OPT	318K	21K		
CUSTOMER NOTICE ANALOG DEVICES HAS BEEN ADVISED THAT THE INFORMATION CONTAINED IN THIS DOCUMENT IS UNCLASSIFIED. IT IS THE POLICY OF ANALOG DEVICES TO MAKE AVAILABLE TO THE PUBLIC INFORMATION THAT IS UNCLASSIFIED AND NOT LAWFULLY RESTRICTED. ANALOG DEVICES IS NOT RESPONSIBLE FOR ANY DAMAGE TO PERSONS OR PROPERTY ARISING FROM ANY ACCIDENTS OR INCIDENTS CAUSED BY ANY INFORMATION CONTAINED IN THIS DOCUMENT. CONTACT ANALOG DEVICES AT ANALOG DEVICES CORPORATION, 100 TAYLOR STREET, FORT LEWIS, COLORADO 80045, USA, FOR FURTHER INFORMATION.				ANALOG DEVICES 3655 AUGUSTINE DRIVE SANTA CLARA, CA 95054 www.analog.com				SCHEMATIC NO. AND REVISION: 710-DC2652A(B)_REV03	
TITLE: SCHEMATIC 3-PHASE, DUAL OUTPUT SYNCHRONOUS BUCK CONVERTER WITH POWER SYSTEM MANAGEMENT				IC NO. LTC3888UG SKU NO. DC2652A				DATE: Tuesday, February 23, 2021	
THE CIRCUIT IS PROPRIETARY TO ANALOG DEVICES AND IS SUPPLIED FOR USE WITH ANALOG DEVICES PARTS.				SIZE: NA				SHEET 1 OF 8	

SCHEMATIC DIAGRAM

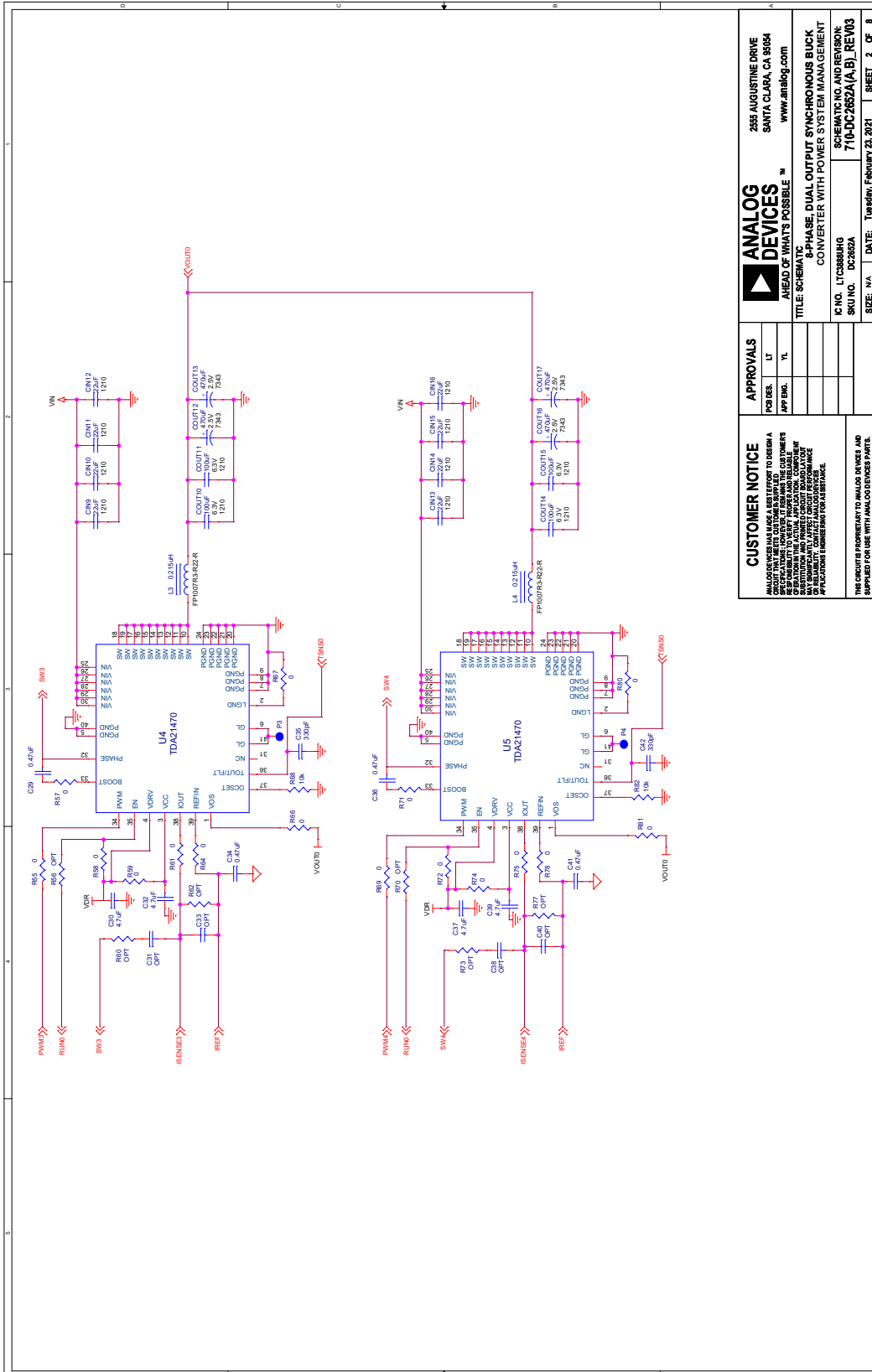

ANALOG DEVICES
 AHEAD OF WHAT'S POSSIBLE™
 2655 AUGUSTINE DRIVE
 SANTA CLARA, CA 95054
 www.analog.com

TITLE: SCHEMATIC
 3-PHASE, DUAL OUTPUT SYNCHRONOUS BUCK
 CONVERTER WITH POWER STATER MANAGEMENT

IC NO. LTC3880UG
SKU NO. DC2652A
DATE: Tuesday, February 23, 2021

SHEET 2 OF 8

APPROVALS

DESIGNER	UT
APP ENGR	YL

CUSTOMER NOTICE
 ANALOG DEVICES IS NOT RESPONSIBLE FOR ANY DAMAGE TO PERSONS OR PROPERTY THAT MAY BE CAUSED BY THE USE OF THIS SCHEMATIC. THE USER ASSUMES ALL LIABILITY FOR ANY DAMAGE TO PERSONS OR PROPERTY THAT MAY BE CAUSED BY THE USE OF THIS SCHEMATIC. ANALOG DEVICES IS NOT RESPONSIBLE FOR ANY DAMAGE TO PERSONS OR PROPERTY THAT MAY BE CAUSED BY THE USE OF THIS SCHEMATIC.

THIS CIRCUIT IS PROPRIETARY TO ANALOG DEVICES AND SUPPLIED FOR USE WITH ANALOG DEVICES PARTS.

DEMO MANUAL DC2652A-B

SCHEMATIC DIAGRAM

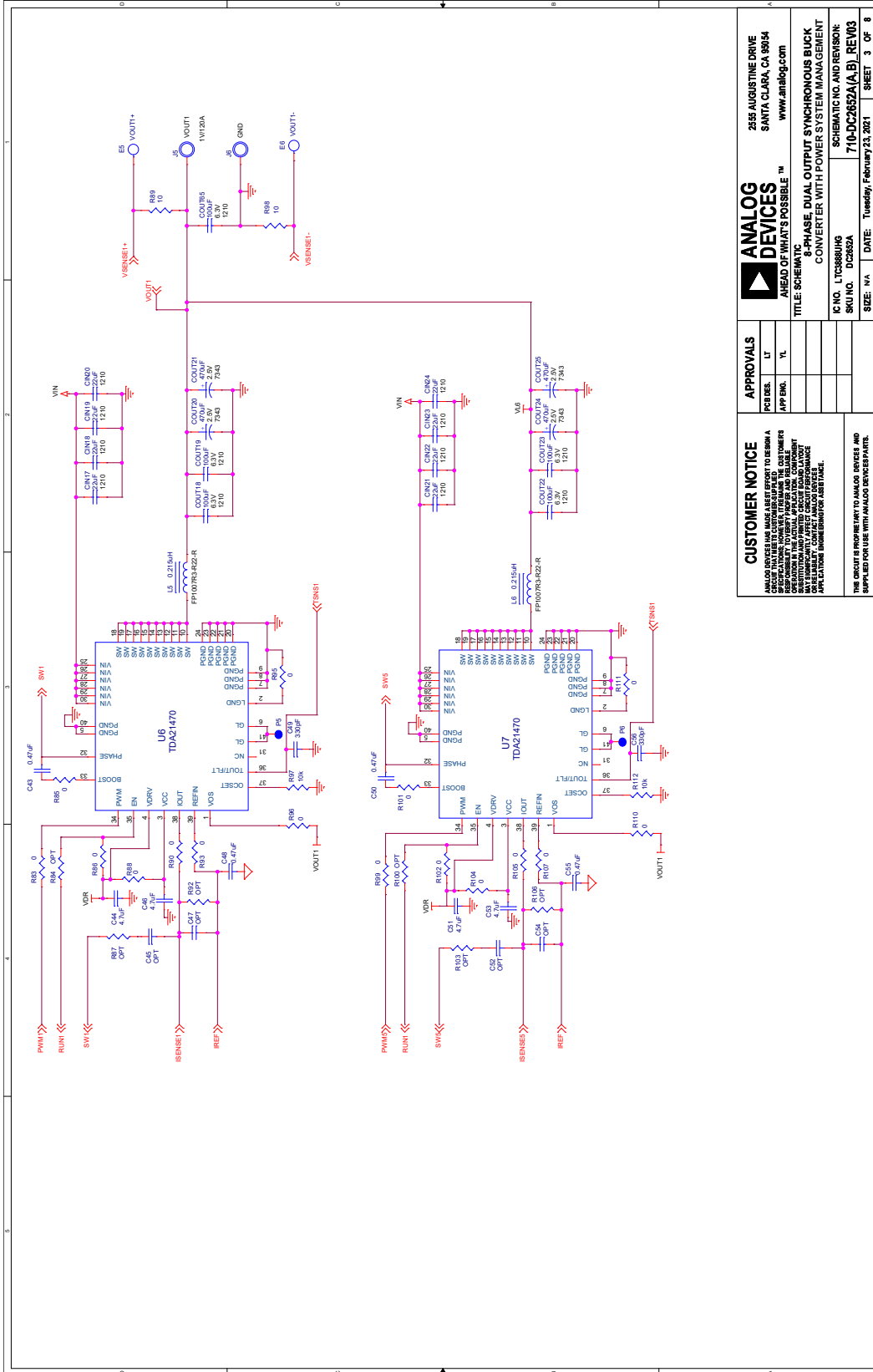

ANALOG DEVICES		2555 AUGUSTINE DRIVE SANTA CLARA, CA 95054 WWW.ANALOG.COM	
AHEAD OF WHAT'S POSSIBLE™		TITLE: SCHEMATIC	
8-PHASE, DUAL OUTPUT SYNCHRONOUS BUCK CONVERTER WITH POWER SYSTEM MANAGEMENT		IC NO. LTC3880H0	
SKU NO. DC2652A		SCHEMATIC NO. AND REVISION: 716-DC2652A(A,B)_REV03	
SIZE: NA	DATE: Tuesday, February 23, 2021	SHEET 3	OF 8

CUSTOMER NOTICE
 ANALOG DEVICES ASSUMES NO LIABILITY TO DESIGN A CUSTOMER'S SYSTEM OR TO DESIGN OR BUILD A CUSTOMER'S SYSTEM. ANALOG DEVICES ASSUMES NO LIABILITY FOR ANY DAMAGE TO PERSONS OR PROPERTY, INCLUDING ANY DAMAGE TO PERSONS OR PROPERTY, ARISING FROM THE USE OF ANY ANALOG DEVICES PRODUCT, INCLUDING ANY ANALOG DEVICES PRODUCT, IN ANY APPLICATION, WITHOUT A PROPERLY DESIGNED AND TESTED PROTOTYPE. ANALOG DEVICES ASSUMES NO LIABILITY FOR ANY DAMAGE TO PERSONS OR PROPERTY, INCLUDING ANY DAMAGE TO PERSONS OR PROPERTY, ARISING FROM THE USE OF ANY ANALOG DEVICES PRODUCT, INCLUDING ANY ANALOG DEVICES PRODUCT, IN ANY APPLICATION, WITHOUT A PROPERLY DESIGNED AND TESTED PROTOTYPE.

APPROVALS	
DESIGNER: UT	DATE:
APP. ENG. YL	DATE:

THE CIRCUIT IS PROPRIETARY TO ANALOG DEVICES AND SUPPLIED FOR USE WITH ANALOG DEVICES PARTS.

SCHEMATIC DIAGRAM

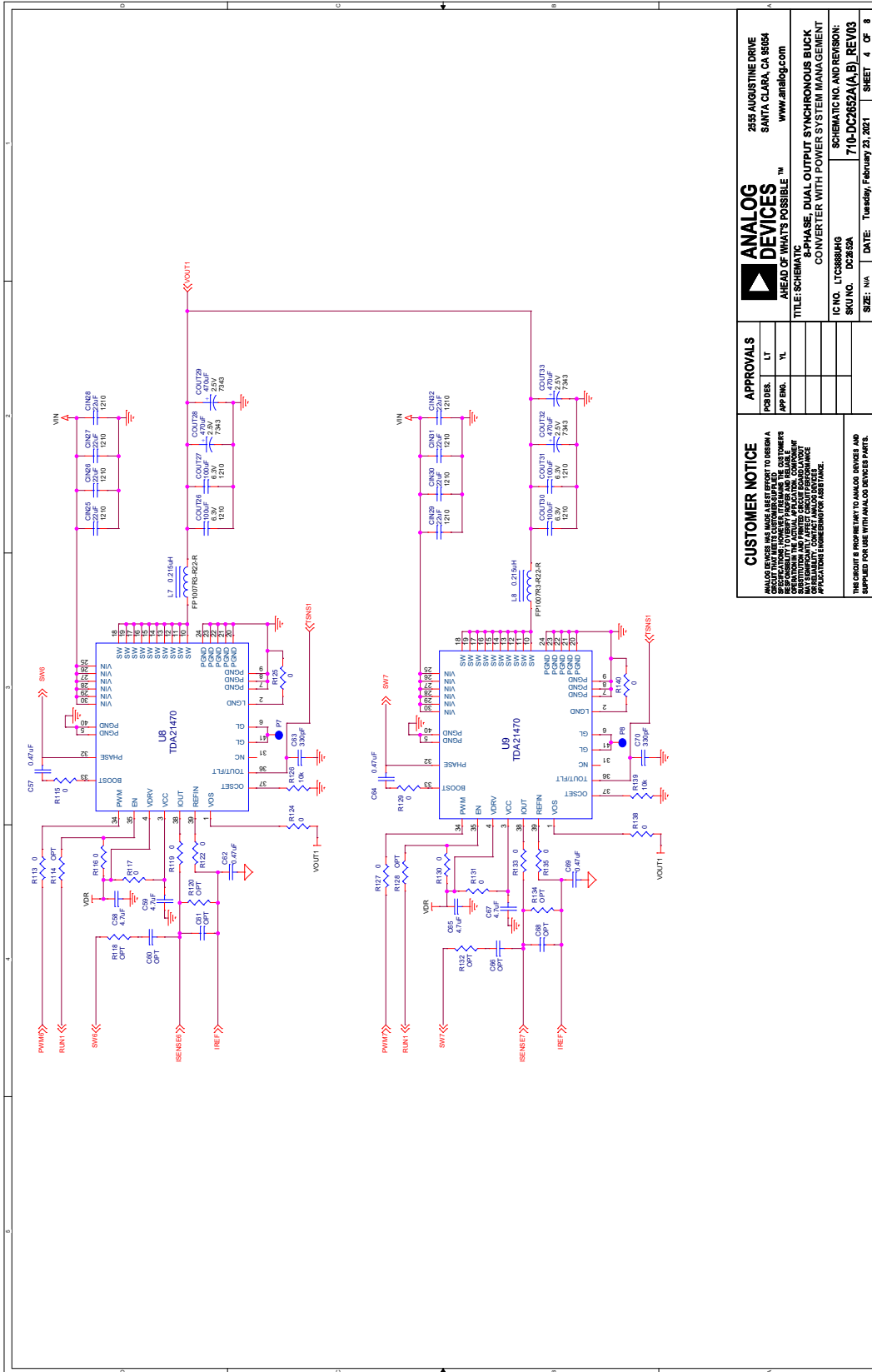

ANALOG DEVICES 2555 AUGUSTINE DRIVE SANTA CLARA, CA 95054 www.analog.com	
AHEAD OF WHAT'S POSSIBLE™	
TITLE: SCHEMATIC 8-PHASE DUAL OUTPUT SYNCHRONOUS BUCK CONVERTER WITH POWER SYSTEM MANAGEMENT	
IC NO. LTC3888RG	SCHEMATIC NO. AND REVISION: 710-DC2652A(B), REV03
SKU NO. DC265A	
SIZE: N/A	DATE: Tuesday, February 23, 2021 SHEET 4 OF 8

CUSTOMER NOTICE
 ANALOG DEVICES PROVIDES DESIGN RESOURCES TO ASSIST YOU AND YOUR DESIGN ENGINEERS WITH DEVELOPING YOUR APPLICATIONS. DESIGN RESOURCES SUCH AS APPLICATION NOTES, REFERENCE DESIGNS, AND TUTORIALS ARE PROVIDED AS GUIDANCE ONLY. IT IS YOUR RESPONSIBILITY TO OBTAIN NECESSARY PATENT RIGHTS FOR ANY DEVICE AND APPLICATION YOU ARE DEVELOPING. ANALOG DEVICES ASSUMES NO LIABILITY FOR APPLICATIONS ASSISTANCE.

THE CREDIT INFORMATION TO ANALOG DEVICES AND SUPPLIED FOR USE WITH ANALOG DEVICES PARTS.

APPROVALS	
DESIGNER	LT
APP'ER	YL

DEMO MANUAL DC2652A-B

SCHEMATIC DIAGRAM

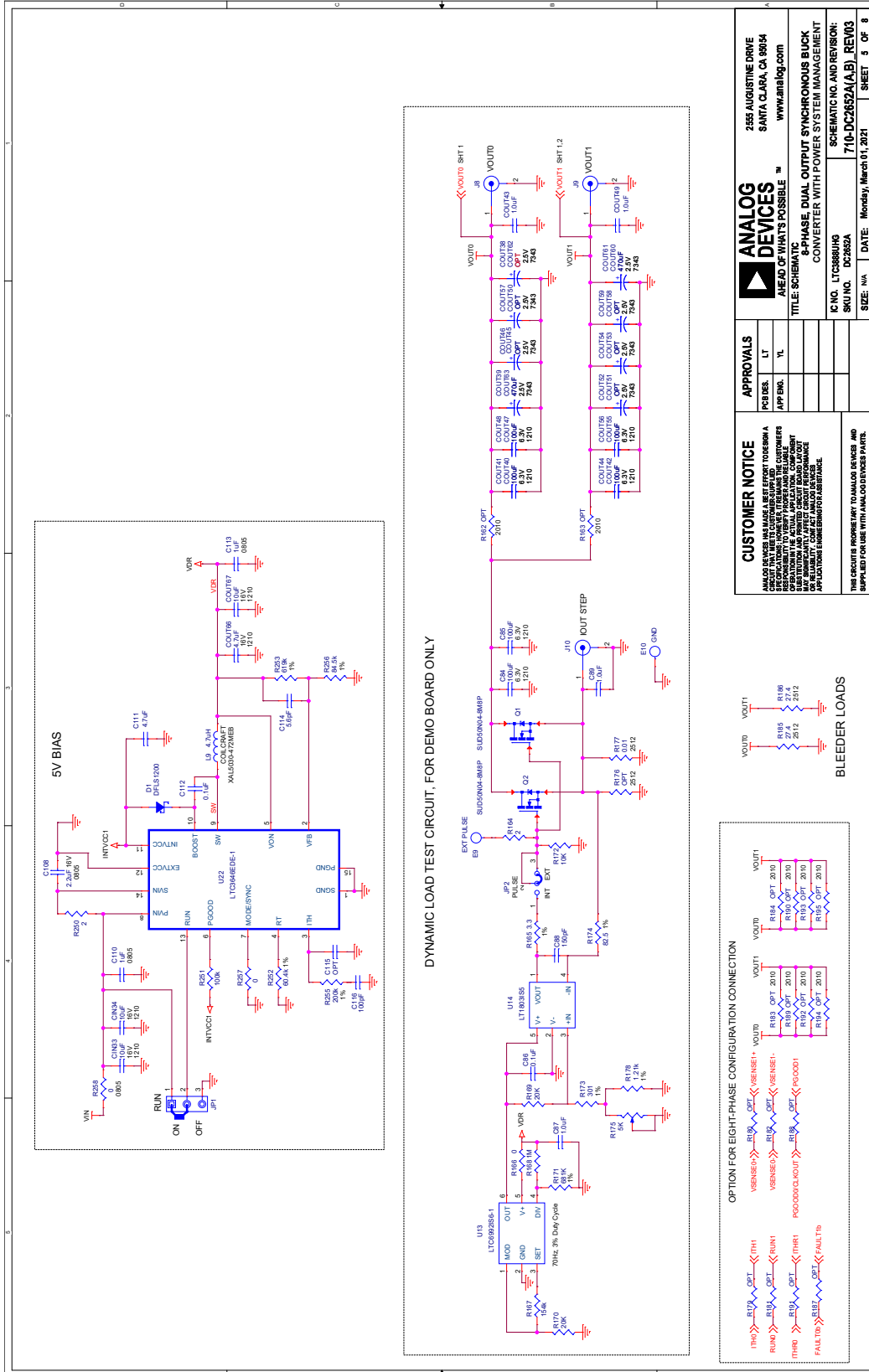

DEMO MANUAL DC2652A-B

SCHEMATIC DIAGRAM

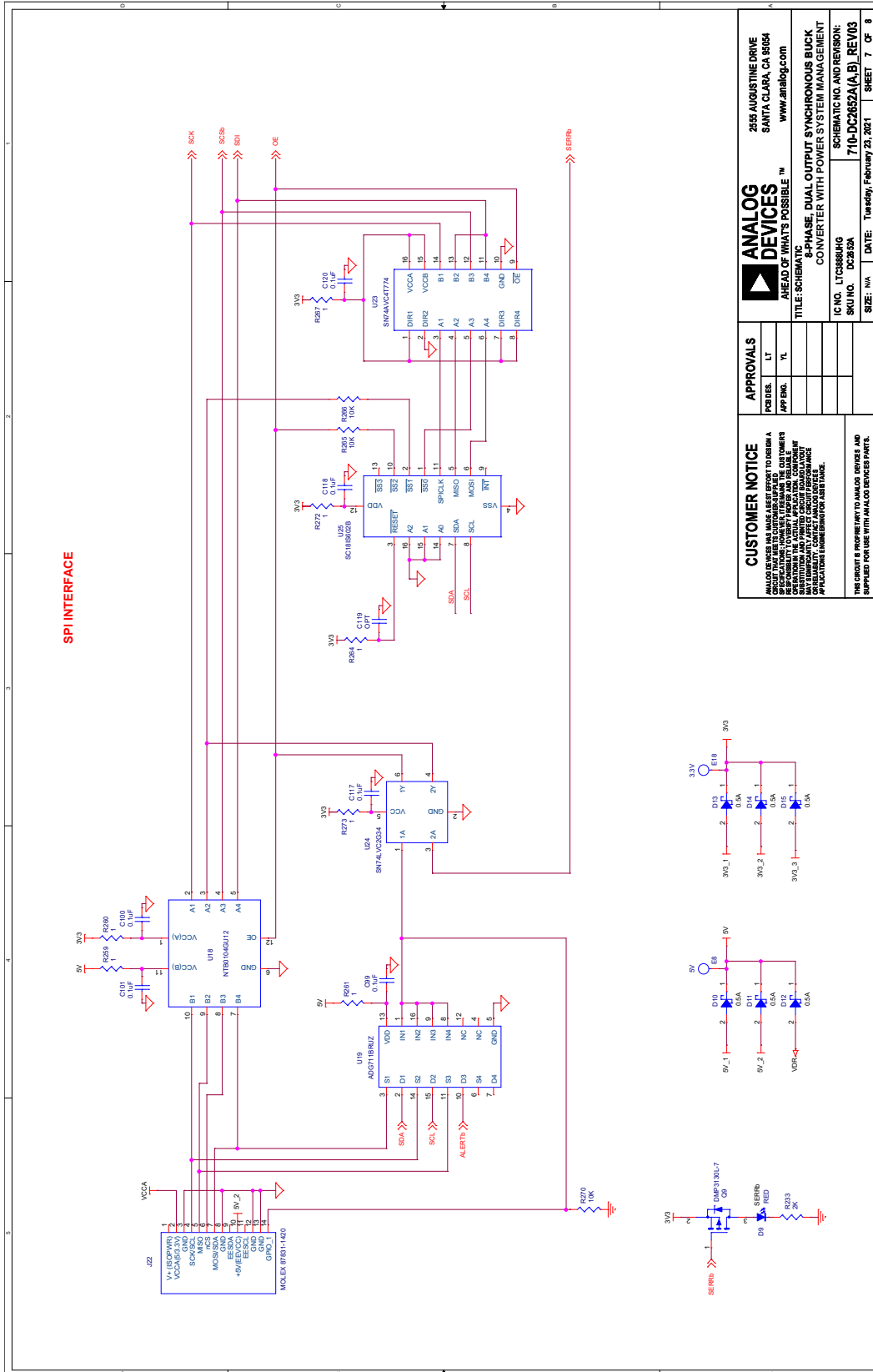

ANALOG DEVICES AHEAD OF WHAT'S POSSIBLE™ www.analog.com		2555 AUGUSTINE DRIVE SANTA CLARA, CA 95054
TITLE: SCHEMATIC 8-PHASE DUAL OUTPUT SYNCHRONOUS BUCK CONVERTER WITH POWER SYSTEM MANAGEMENT		IC NO. LTC3888BHG
SHEET NO. DC2652A		SCHEMATIC NO. AND REVISION: 710-DC2652A(A,B), REV03
DATE: Tuesday, February 23, 2021	SIZE: N/A	SHEET 7 OF 8

CUSTOMER NOTICE
 ANALOG DEVICES IS PROVIDING THIS SCHEMATIC TO YOU AS A SERVICE TO OUR CUSTOMERS. THIS SCHEMATIC IS PROVIDED AS-IS AND DOES NOT REPRESENT A CONTRACT. ANALOG DEVICES IS NOT RESPONSIBLE FOR ANY ERRORS OR OMISSIONS IN THIS SCHEMATIC. ANALOG DEVICES IS NOT PROVIDING ANY WARRANTIES, EXPRESS OR IMPLIED, INCLUDING BUT NOT LIMITED TO, MERCHANTABILITY, FITNESS FOR A PARTICULAR PURPOSE, OR NON-INFRINGEMENT. ANALOG DEVICES IS PROVIDING THIS SCHEMATIC FOR INFORMATIONAL PURPOSES ONLY. ANALOG DEVICES IS NOT PROVIDING ANY SUPPORT FOR THIS SCHEMATIC.

THE CREDIT IS IMPROVED BY ANALOG DEVICES AND SUPPLIED FOR USE WITH ANALOG DEVICES PARTS.

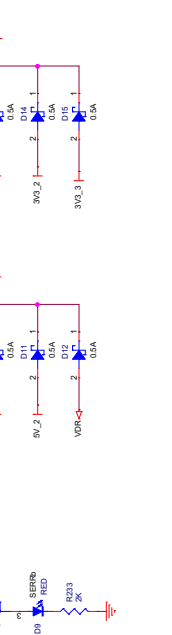

SCHEMATIC DIAGRAM

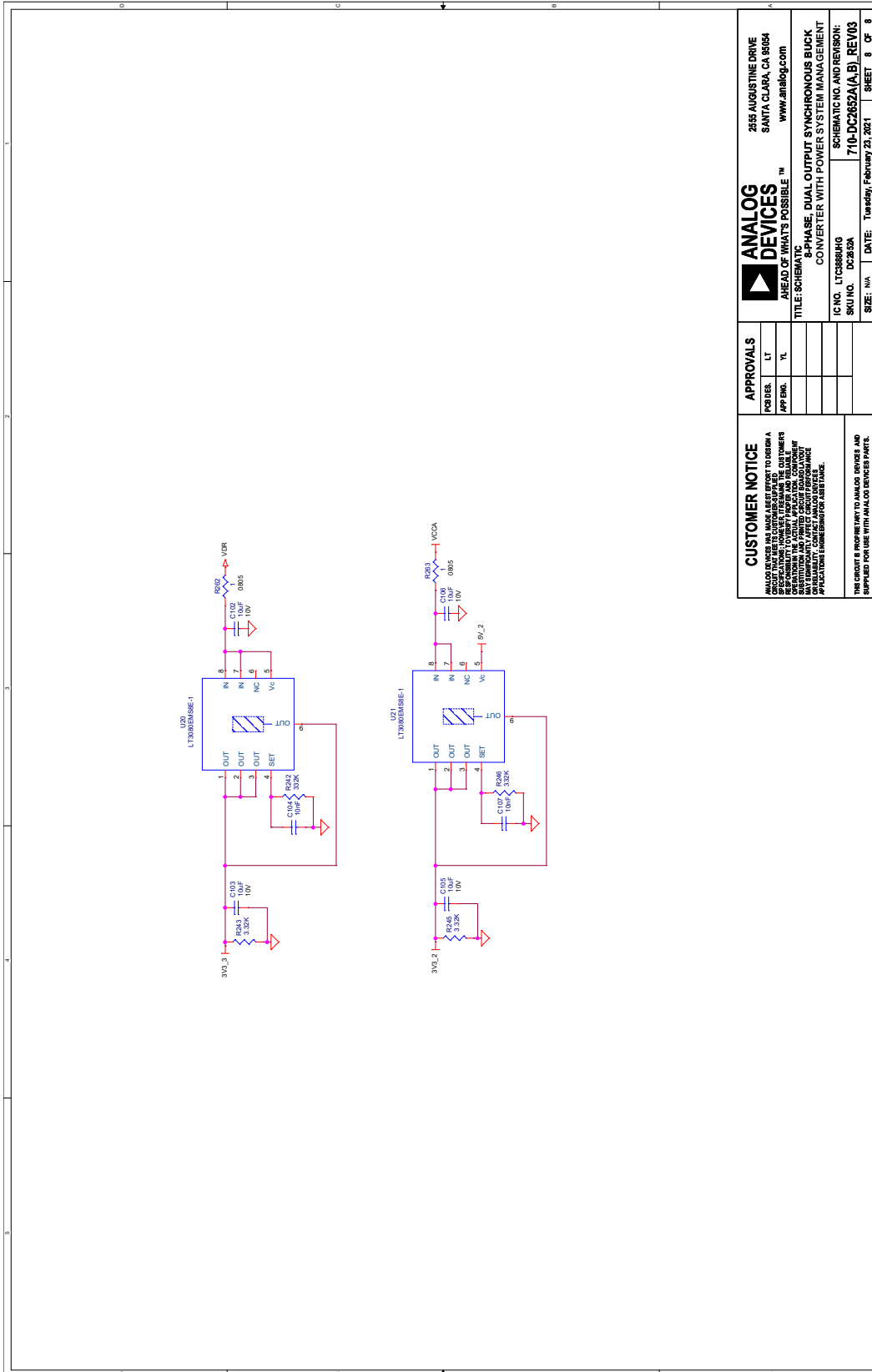

ANALOG DEVICES 2555 AUGUSTINE DRIVE SANTA CLARA, CA 95054 www.analog.com		IC NO. LT3888BUK	
AHEAD OF WHAT'S POSSIBLE™		SCHEMATIC NO. AND REVISION:	
TITLE: SCHEMATIC		710-DC2652A(A,B) REV03	
8-PHASE, DUAL OUTPUT SYNCHRONOUS BUCK CONVERTER WITH POWER SYSTEM MANAGEMENT		SKU NO. DC265A	
CUSTOMER NOTICE		SIZE: N/A	
ANALOG DEVICES AND ITS REPRESENTATIVES MAKE NO WARRANTY TO DESIGN A CUSTOMER'S PRODUCT OR TO OPERATE THE CUSTOMER'S PRODUCT IN ANY APPLICATION OR TO MEET ANY SPECIFIC REQUIREMENTS OF A CUSTOMER'S APPLICATION. THE CUSTOMER IS RESPONSIBLE FOR THE PROPER DESIGN AND OPERATION OF THE CUSTOMER'S PRODUCT. ANALOG DEVICES AND ITS REPRESENTATIVES ARE NOT RESPONSIBLE FOR ANY DAMAGE TO THE CUSTOMER'S PRODUCT OR FOR ANY LOSS OF PROFITS OR REVENUE. ANALOG DEVICES AND ITS REPRESENTATIVES ARE NOT RESPONSIBLE FOR ANY INFRINGEMENTS OF PATENTS OR OTHER RIGHTS OF THIRD PARTIES THAT MAY RESULT FROM THE USE OF THIS SCHEMATIC.		DATE: Tuesday, February 23, 2021	
THE CREDIT IS PROPERTY OF ANALOG DEVICES AND IS NOT TO BE REPRODUCED OR TRANSMITTED IN ANY FORM OR BY ANY MEANS, ELECTRONIC OR MECHANICAL, INCLUDING PHOTOCOPYING, RECORDING, OR BY ANY INFORMATION STORAGE AND RETRIEVAL SYSTEM.		SHEET 8 OF 8	



ESD Caution

ESD (electrostatic discharge) sensitive device. Charged devices and circuit boards can discharge without detection. Although this product features patented or proprietary protection circuitry, damage may occur on devices subjected to high energy ESD. Therefore, proper ESD precautions should be taken to avoid performance degradation or loss of functionality.

Legal Terms and Conditions

By using the evaluation board discussed herein (together with any tools, components documentation or support materials, the Evaluation Board), you are agreeing to be bound by the terms and conditions set forth below (Agreement) unless you have purchased the Evaluation Board, in which case the Analog Devices Standard Terms and Conditions of Sale shall govern. Do not use the Evaluation Board until you have read and agreed to the Agreement. Your use of the Evaluation Board shall signify your acceptance of the Agreement. This Agreement is made by and between you (Customer) and Analog Devices, Inc. (ADI), with its principal place of business at One Technology Way, Norwood, MA 02062, USA. Subject to the terms and conditions of the Agreement, ADI hereby grants to Customer a free, limited, personal, temporary, non-exclusive, non-sublicensable, non-transferable license to use the Evaluation Board FOR EVALUATION PURPOSES ONLY. Customer understands and agrees that the Evaluation Board is provided for the sole and exclusive purpose referenced above, and agrees not to use the Evaluation Board for any other purpose. Furthermore, the license granted is expressly made subject to the following additional limitations: Customer shall not (i) rent, lease, display, sell, transfer, assign, sublicense, or distribute the Evaluation Board; and (ii) permit any Third Party to access the Evaluation Board. As used herein, the term Third Party includes any entity other than ADI, Customer, their employees, affiliates and in-house consultants. The Evaluation Board is NOT sold to Customer; all rights not expressly granted herein, including ownership of the Evaluation Board, are reserved by ADI. CONFIDENTIALITY. This Agreement and the Evaluation Board shall all be considered the confidential and proprietary information of ADI. Customer may not disclose or transfer any portion of the Evaluation Board to any other party for any reason. Upon discontinuation of use of the Evaluation Board or termination of this Agreement, Customer agrees to promptly return the Evaluation Board to ADI. ADDITIONAL RESTRICTIONS. Customer may not disassemble, decompile or reverse engineer chips on the Evaluation Board. Customer shall inform ADI of any occurred damages or any modifications or alterations it makes to the Evaluation Board, including but not limited to soldering or any other activity that affects the material content of the Evaluation Board. Modifications to the Evaluation Board must comply with applicable law, including but not limited to the RoHS Directive. TERMINATION. ADI may terminate this Agreement at any time upon giving written notice to Customer. Customer agrees to return to ADI the Evaluation Board at that time. LIMITATION OF LIABILITY. THE EVALUATION BOARD PROVIDED HEREUNDER IS PROVIDED AS IS AND ADI MAKES NO WARRANTIES OR REPRESENTATIONS OF ANY KIND WITH RESPECT TO IT. ADI SPECIFICALLY DISCLAIMS ANY REPRESENTATIONS, ENDORSEMENTS, GUARANTEES, OR WARRANTIES, EXPRESS OR IMPLIED, RELATED TO THE EVALUATION BOARD INCLUDING, BUT NOT LIMITED TO, THE IMPLIED WARRANTY OF MERCHANTABILITY, TITLE, FITNESS FOR A PARTICULAR PURPOSE OR NON-INFRINGEMENT OF INTELLECTUAL PROPERTY RIGHTS. IN NO EVENT WILL ADI AND ITS LICENSORS BE LIABLE FOR ANY INCIDENTAL, SPECIAL, INDIRECT, OR CONSEQUENTIAL DAMAGES RESULTING FROM CUSTOMER'S POSSESSION OR USE OF THE EVALUATION BOARD, INCLUDING BUT NOT LIMITED TO LOST PROFITS, DELAY COSTS, LABOR COSTS OR LOSS OF GOODWILL. ADI'S TOTAL LIABILITY FROM ANY AND ALL CAUSES SHALL BE LIMITED TO THE AMOUNT OF ONE HUNDRED US DOLLARS (\$100.00). EXPORT. Customer agrees that it will not directly or indirectly export the Evaluation Board to another country, and that it will comply with all applicable United States federal laws and regulations relating to exports. GOVERNING LAW. This Agreement shall be governed by and construed in accordance with the substantive laws of the Commonwealth of Massachusetts (excluding conflict of law rules). Any legal action regarding this Agreement will be heard in the state or federal courts having jurisdiction in Suffolk County, Massachusetts, and Customer hereby submits to the personal jurisdiction and venue of such courts. The United Nations Convention on Contracts for the International Sale of Goods shall not apply to this Agreement and is expressly disclaimed.