

GENERAL TOLERANCE										USED ON
10 MAX	30 MAX	50 MAX	70 MAX	100 MAX	120 MAX	250 MAX	250 OVER	ANGLE	ECCENT	
±0.15	±0.20	±0.30	±0.40	±0.50	±0.75	±0.90	±1.4	±0.5°	0.1	

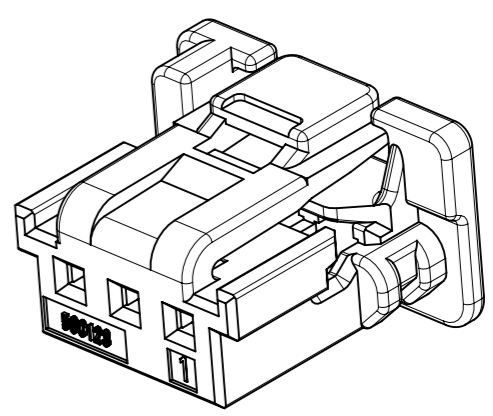

ISO VIEW

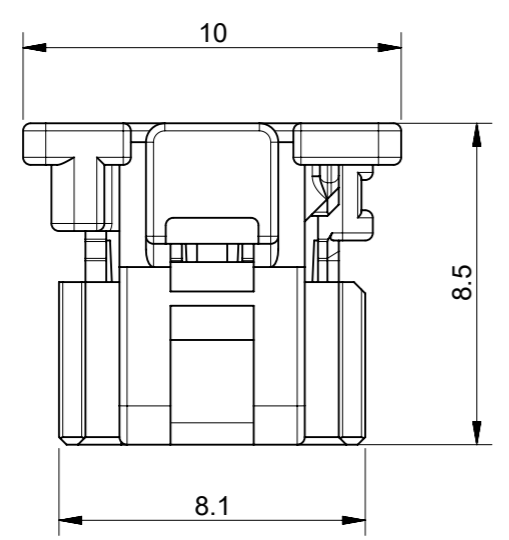
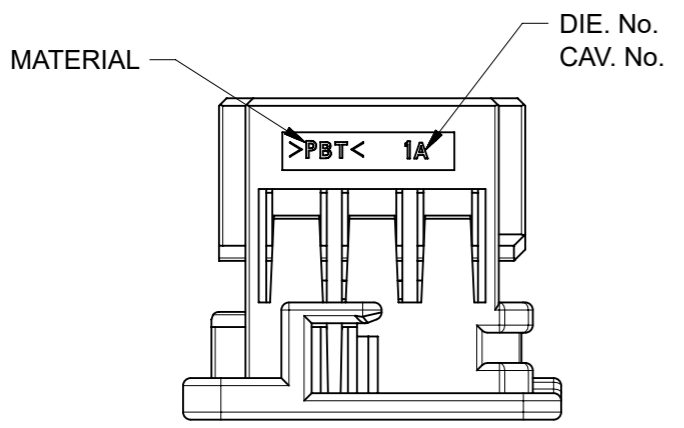
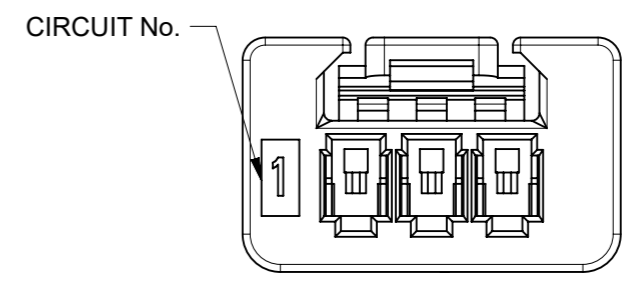
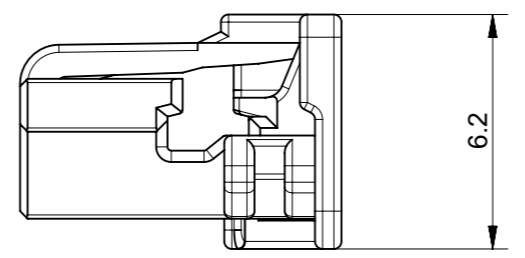
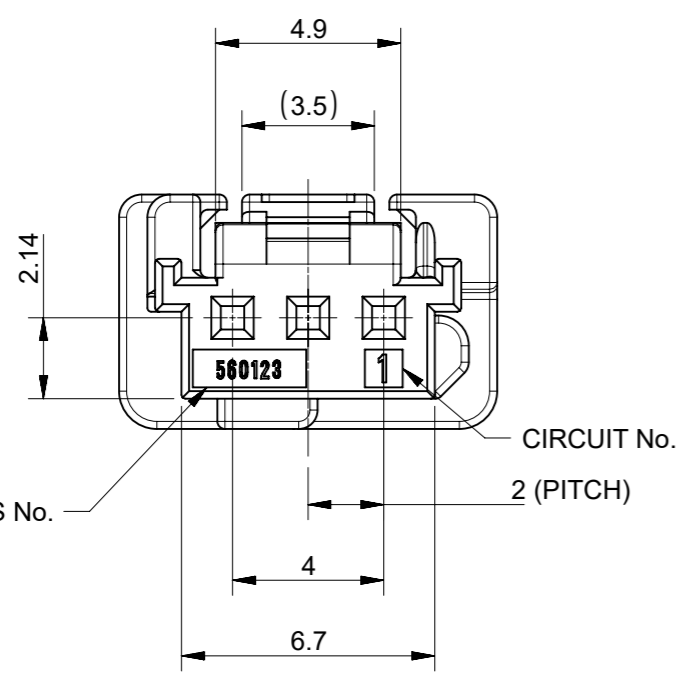

- NOTES:
1. MATERIALS : POLYESTER (PBT), GLASS UNFILLED, UL94 V-0
  2. MATE WITH : 502352, 560020 SERIES
  3. APPLICABLE TERMINAL : 560124 SERIES
  4. APPLICABLE ISL : 560125 SERIES
  5. GENERAL TOLERANCE : SEE TABLE
  6. EVL AND RoHS COMPLIANT
  7. PRODUCT SPECIFICATION : PS-560123-00\*
  8. PACKING SPECIFICATION : PK-560123-001

MATERIAL NUMBER

ORDER NO.	MATERIAL NO.	COLOR
560123-0300	5601230300	WHITE
560123-0301	5601230301	BLACK
560123-0302	5601230302	RED
560123-0304	5601230304	BLUE

FUNCTIONAL SYMBOLS	THIS DRAWING CONTAINS INFORMATION THAT IS PROPRIETARY TO MOLEX ELECTRONIC TECHNOLOGIES, LLC AND SHOULD NOT BE USED WITHOUT WRITTEN PERMISSION	CURRENT REV DESC:																																					
	<table border="1"> <tr> <th>FUNCTIONAL SYMBOLS</th> <th>DIMENSION UNITS</th> <th>SCALE</th> </tr> <tr> <td><math>\nabla_A = 0</math></td> <td>mm</td> <td>5:1</td> </tr> <tr> <td><math>\nabla_E = 0</math></td> <td colspan="2">GENERAL TOLERANCES (UNLESS SPECIFIED)</td> </tr> <tr> <td><math>\nabla_{E'} = 0</math></td> <td colspan="2">ANGULAR TOL ± °</td> </tr> <tr> <td></td> <td>4 PLACES</td> <td>±</td> </tr> <tr> <td></td> <td>3 PLACES</td> <td>±</td> </tr> <tr> <td></td> <td>2 PLACES</td> <td>±</td> </tr> <tr> <td></td> <td>1 PLACE</td> <td>±</td> </tr> <tr> <td></td> <td>0 PLACES</td> <td>±</td> </tr> </table>	FUNCTIONAL SYMBOLS	DIMENSION UNITS				SCALE	$\nabla_A = 0$	mm	5:1	$\nabla_E = 0$	GENERAL TOLERANCES (UNLESS SPECIFIED)		$\nabla_{E'} = 0$	ANGULAR TOL ± °			4 PLACES	±		3 PLACES	±		2 PLACES	±		1 PLACE	±		0 PLACES	±	<table border="1"> <tr> <td>EC NO: 668822</td> <td>2021/07/01</td> </tr> <tr> <td>DRWN: SAKIM</td> <td>2021/07/05</td> </tr> <tr> <td>CHK'D: HIJIMA</td> <td>2021/07/05</td> </tr> <tr> <td>APPR: HIJIMA</td> <td>2021/07/05</td> </tr> </table>	EC NO: 668822	2021/07/01	DRWN: SAKIM	2021/07/05	CHK'D: HIJIMA	2021/07/05	APPR: HIJIMA
FUNCTIONAL SYMBOLS	DIMENSION UNITS	SCALE																																					
$\nabla_A = 0$	mm	5:1																																					
$\nabla_E = 0$	GENERAL TOLERANCES (UNLESS SPECIFIED)																																						
$\nabla_{E'} = 0$	ANGULAR TOL ± °																																						
	4 PLACES	±																																					
	3 PLACES	±																																					
	2 PLACES	±																																					
	1 PLACE	±																																					
	0 PLACES	±																																					
EC NO: 668822	2021/07/01																																						
DRWN: SAKIM	2021/07/05																																						
CHK'D: HIJIMA	2021/07/05																																						
APPR: HIJIMA	2021/07/05																																						
DIVISIONAL SYMBOLS	INITIAL REVISION:		PRODUCT CUSTOMER DRAWING																																				
	DRWN: YIBAEK	2014/07/08	DOCUMENT NUMBER																																				
	APPR: SRTAK	2014/08/26	DOC TYPE DOC PART REVISION																																				
	DRAFT WHERE APPLICABLE MUST REMAIN WITHIN DIMENSIONS		SD-560123-003																																				
	THIRD ANGLE PROJECTION	DRAWING	SERIES	MATERIAL NUMBER	CUSTOMER																																		
		A3-SIZE	560123	SEE TABLE	GENERAL MARKET																																		
					SHEET NUMBER																																		
					1 OF 1																																		