

UM11178

RDGD3100I3PH5EVB three-phase inverter reference design

Rev. 1 — 28 May 2019

User manual

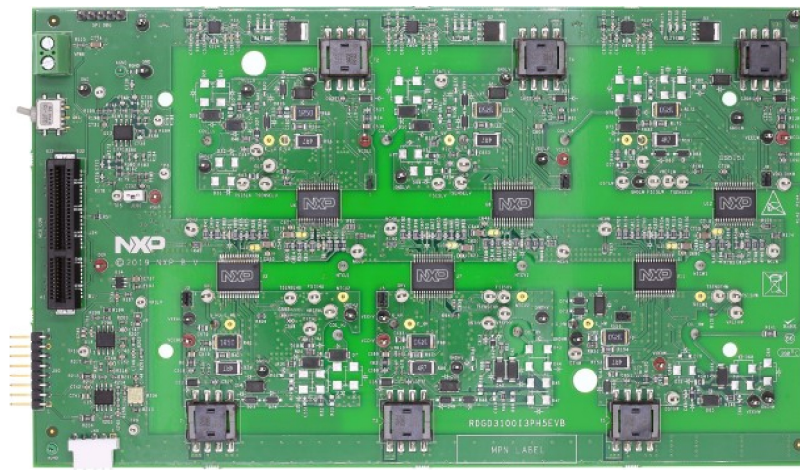

aaa-032593

Figure 1. RDGD3100I3PH5EVB

Important Notice

NXP provides the enclosed product(s) under the following conditions:

This reference design is intended for use of ENGINEERING DEVELOPMENT OR EVALUATION PURPOSES ONLY. It is provided as a sample IC pre-soldered to a printed circuit board to make it easier to access inputs, outputs, and supply terminals. This reference design may be used with any development system or other source of I/O signals by simply connecting it to the host MCU or computer board via off-the-shelf cables. Final device in an application will be heavily dependent on proper printed circuit board layout and heat sinking design as well as attention to supply filtering, transient suppression, and I/O signal quality.

The goods provided may not be complete in terms of required design, marketing, and or manufacturing related protective considerations, including product safety measures typically found in the end product incorporating the goods. Due to the open construction of the product, it is the user's responsibility to take any and all appropriate precautions with regard to electrostatic discharge. In order to minimize risks associated with the customers applications, adequate design and operating safeguards must be provided by the customer to minimize inherent or procedural hazards. For any safety concerns, contact NXP sales and technical support services.

Should this reference design not meet the specifications indicated in the kit, it may be returned within 30 days from the date of delivery and will be replaced by a new kit.

NXP reserves the right to make changes without further notice to any products herein. NXP makes no warranty, representation or guarantee regarding the suitability of its products for any particular purpose, nor does NXP assume any liability arising out of the application or use of any product or circuit, and specifically disclaims any and all liability, including without limitation consequential or incidental damages. Typical parameters can and do vary in different applications and actual performance may vary over time. All operating parameters, including Typical, must be validated for each customer application by customer's technical experts.

NXP does not convey any license under its patent rights nor the rights of others. NXP products are not designed, intended, or authorized for use as components in systems intended for surgical implant into the body, or other applications intended to support or sustain life, or for any other application in which the failure of the NXP product could create a situation where personal injury or death may occur.

Should the Buyer purchase or use NXP products for any such unintended or unauthorized application, the Buyer shall indemnify and hold NXP and its officers, employees, subsidiaries, affiliates, and distributors harmless against all claims, costs, damages, and expenses, and reasonable attorney fees arising out of, directly or indirectly, any claim of personal injury or death associated with such unintended or unauthorized use, even if such claim alleges NXP was negligent regarding the design or manufacture of the part.



1 Introduction

This document is the user guide for the RDGD3100I3PH5EVB reference design. This document is intended for the engineers involved in the evaluation, design, implementation, and validation of single-channel gate driver for IGBT, GD3100.

The scope of this document is to provide the user with information to evaluate the single channel gate driver for IGBT, GD3100. This document covers connecting the hardware, installing the software and tools, configuring the environment and using the kit.

The RDGD3100I3PH5EVB is a fully functional three-phase inverter evaluation board populated with six GD3100 gate drivers with fault management and supporting circuitry. This board supports SPI daisy chain communication for programming and communication with three high-side gate drivers and three low-side gate drivers independently.

This board has low-voltage and high-voltage isolation in conjunction with gate drive integrated galvanic signal isolation. Other supporting features on the board include desaturation short-circuit detection, IGBT temperature sensing, DC Link bus voltage monitoring, phase current sensing, and motor resolver excitation and signal processing connection circuitry. See GD3100 data sheet for additional gate drive features.

2 Finding kit resources and information on the NXP web site

The NXP analog product development boards provide an easy-to-use platform for evaluating NXP products. The boards support a range of analog, mixed-signal and power solutions. They incorporate monolithic integrated circuits and system-in-package devices that use proven high-volume technology. NXP products offer longer battery life, a smaller form factor, reduced component counts, lower cost and improved performance in powering state-of-the-art systems.

NXP Semiconductors provides online resources for this reference design and its supported device(s) on <http://www.nxp.com>.

The information page for RDGD3100I3PH5EVB reference design is at <http://www.nxp.com/RDGD3100I3PH5EVB>. The information page provides overview information, specifications, ordering information, documentation and software. The **Documents and Software** tab provides quick-reference information applicable to using the RDGD3100I3PH5EVB reference design, including the downloadable assets referenced in this document.

2.1 Collaborate in the NXP community

The NXP community is for sharing ideas and tips, ask and answer technical questions, and receive input on just about any embedded design topic.

The NXP community is at <http://community.nxp.com>.

3 Getting started

Working with the RDGD3100I3PH5EVB requires the kit contents, additional hardware, and a Windows PC workstation with installed software.

3.1 Kit contents

- Assembled and tested RDGD3100I3PH5EVB (three-phase inverter populated with 5.0 V compatible gate driver devices) board in an anti-static bag
- One PCIe cable (X-S32SDEV-CON18) for connection to MCU board ([MPC5777C-DEVB](#) or [MPC5744P](#))
- Quick Start Guide

3.2 Additional hardware

In addition to the kit contents, the following hardware is necessary or beneficial when working with this kit.

- Microcontroller for SPI communication
- IGBT module Infineon HP Drive
- DC link capacitor compatible with IGBT part FS820R08A6P2B
- HV power supply with protection shield and hearing protection
- Current sensors for monitoring each phase current
- 12 V, 1.0 A DC power supply
- TEK MSO 4054 500 MHz 2.5 GS/s 4-channel oscilloscope

3.3 Windows PC workstation

This reference design requires a Windows PC workstation. Meeting these minimum specifications should produce great results when working with this evaluation board.

- USB-enabled computer with Windows 7 or Windows 10

3.4 Software

Installing software is necessary to work with this reference design. All listed software is available on the reference design's information page at <http://www.nxp.com/RDGD3100I3PH5EVB>.

- S32S Design Studio IDE for power architecture
- Automotive Math and Motor Control Library (AMMCL)
- FreeMaster 2.0 runtime debugging tool
- Motor Control Application Tuning (MCAT)
- Example code, GD3100 Device Driver notes and GD3100 Device Driver Reference notes

4 Getting to know the hardware

4.1 Kit overview

4.1.1 RDGD3100I3PH5EVB features

- Capability to connect to HP Drive IGBT modules for full three-phase evaluation and development
- Daisy chain SPI communication (three high-side and three low-side gate drivers)
- Power supply which is jumper configurable for VEE negative or GND reference
- Easy access power, ground, and signal test points

- 2x32 PCIe socket for interfacing MCU control
- Optional connection for DC bus voltage monitoring
- Compatible with [MPC5777C-DEVB](#)

4.1.2 Voltage domains, GD3100 pinout, logic header, and IGBT pinout

Low-voltage domain is an externally supplied 12 V DC (VSUP) primary supply for non-isolated circuits, typically supplied by vehicle battery. The low-voltage domain includes the interface between the MCU and GD3100 control registers and logic control.

Low-side driver and high-side driver domains are isolated high-voltage driver control domains for IGBT single phase connections and control circuits. Pins on bottom of board are designed to easily connect to three-phase IGBT module.

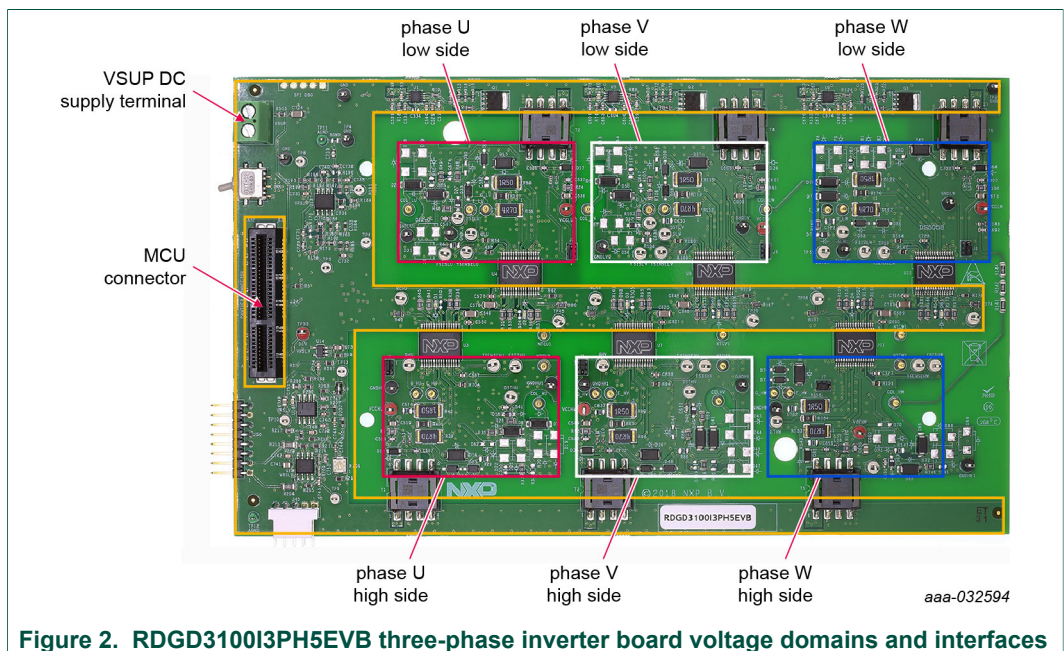

Figure 2. RDGD3100I3PH5EVB three-phase inverter board voltage domains and interfaces

4.2 Featured components

4.2.1 Advanced IGBT gate driver

4.2.1.1 General description

The GD3100 is an advanced single channel gate driver for IGBTs. Integrated Galvanic isolation and low on-resistance drive transistors provide high charging and discharging current, low dynamic saturation voltage, and rail-to-rail gate voltage control.

Current and temperature sense minimizes IGBT stress during faults. Accurate and configurable under voltage lockout (UVLO) provides protection while ensuring sufficient gate drive voltage headroom.

The GD3100 autonomously manages severe faults and reports faults and status via INTB pin and a SPI interface. It is capable of directly driving gates of most IGBTs. Self-test, control, and protection functions are included for design of high reliability systems (ASIL C/D). It meets the stringent requirements of automotive applications and is fully AEC-Q100 grade 1 qualified.

4.2.1.2 GD3100 features

- Compatible with current sense and temp sense IGBTs
- Fast short-circuit protection for IGBTs with current sense feedback
- Compliant with ASIL D ISO 26262 functional safety requirements
- SPI interface for safety monitoring, programmability, and flexibility
- Integrated Galvanic signal isolation
- Integrated gate drive power stage capable of 10 A peak source and sink
- Interrupt pin for fast response to faults
- Compatible with negative gate supply
- Compatible with 200 V to 1700 V IGBTs, power range > 125 kW
- AEC-Q100 grade 1 qualified

4.2.2 GD3100 pinout and MCU interface pinout

See GD3100 advanced IGBT gate driver data sheet for specific information about pinout, pin descriptions, specifications, and operating modes.

VSUP DC supply terminal is a low voltage input connection for supplying power to the low voltage non-isolated die and related circuitry. Typically supplied by vehicle battery +12 V DC.

MCU connector is a 2×32-pin PCIe interface connector for use with either MPC5744P or MPC5777C 32-bit MCU board or any other MCU of preference. An MCU is needed for SPI communication and control of advanced IGBT gate drive devices (GD3100).

RDGD3100I3PH5EVB three-phase inverter reference design

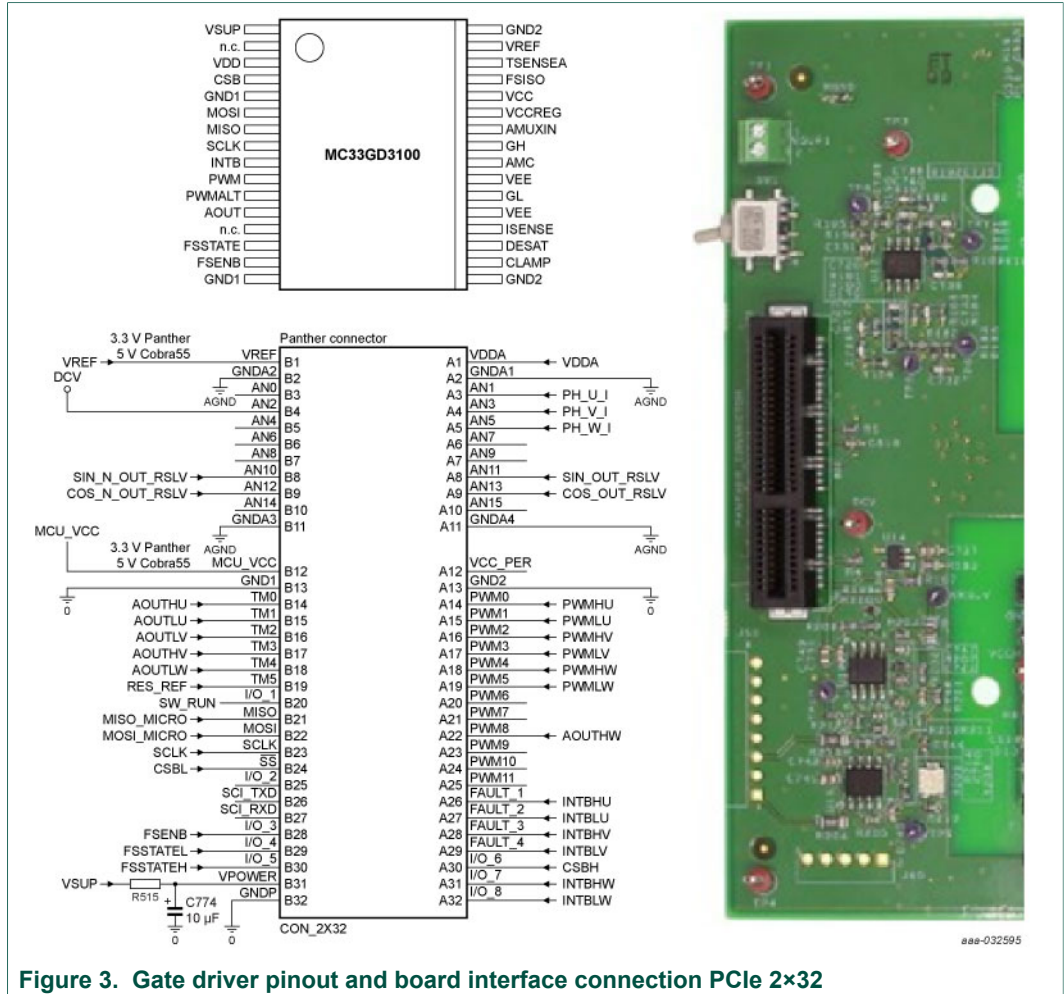

Figure 3. Gate driver pinout and board interface connection PCIe 2x32

Table 1. PCIe connector pin definitions

Pin	Name	Function
A1	VDDA	Voltage reference resolver circuit
A2	GND1	Analog ground
A3	PH_U_I	Current feedback phase U
A4	PH_V_I	Current feedback phase V
A5	PH_W_I	Current feedback phase W
A6	n.c.	not connected
A7	n.c.	not connected
A8	SIN_OUT_RSLV	Sine resolver signal
A9	COS_OUT_RSLV	Cosine resolver signal
A10	n.c.	not connected
A11	GND4	Analog ground
A12	n.c.	not connected
A13	GND2	Ground
A14	PWMHU	Pulse width modulation high-side phase U
A15	PWMLU	Pulse width modulation low-side phase U

RDGD3100I3PH5EV3 three-phase inverter reference design

Pin	Name	Function
A16	PWMHV	Pulse width modulation high-side phase V
A17	PWMLV	Pulse width modulation low-side phase V
A18	PWMHW	Pulse width modulation high-side phase W
A19	PWMLW	Pulse width modulation low-side phase W
A20	n.c.	not connected
A21	n.c.	not connected
A22	AOUTHW	Analog output signal high-side phase W
A23	n.c.	not connected
A24	n.c.	not connected
A25	n.c.	not connected
A26	INTBHU	GD3100 fault reporting pin for high-side phase U
A27	INTBLU	GD3100 fault reporting pin for low-side phase U
A28	INTBHV	GD3100 fault reporting pin for high-side phase V
A29	INTBLV	GD3100 fault reporting pin for low-side phase V
A30	CSBH	Chip select bar to high gate drive devices
A31	INTBHW	GD3100 fault reporting pin for high-side phase W
A32	INTBLW	GD3100 fault reporting pin for low-side phase W
B1	VREF	Voltage reference from MCU
B2	GND A2	Analog ground
B3	NC	not connected
B4	DCV	Optional DC bus voltage monitoring (not used by default)
B5	n.c.	not connected
B6	n.c.	not connected
B7	n.c.	not connected
B8	SIN_N_OUT_RSLV	Sine resolver signal
B9	COS_N_OUT_RSLV	Cosine resolver signal
B10	n.c.	not connected
B11	GND A3	Analog ground
B12	MCU_VCC	MCU VCC regulator voltage
B13	GND1	Ground
B14	AOUTHU	GD3100 analog output signal high-side U phase
B15	AOUTLU	GD3100 analog output signal low-side U phase
B16	AOUTLV	GD3100 analog output signal low-side V phase
B17	AOUTHV	GD3100 analog output signal high-side V phase
B18	AOUTLW	GD3100 analog output signal low-side W phase
B19	RES_REF	Resolver reference voltage
B20	SW_RUN	Signal from onboard switch demo mode
B21	MISO_MICRO	SPI slave out signal
B22	MOSI_MICRO	SPI slave in signal
B23	SCLK	SPI clock
B24	CSBL	Chip select bar to low-side gate drivers

Pin	Name	Function
B25	n.c.	not connected
B26	n.c.	not connected
B27	n.c.	not connected
B28	FSENB	Fail-safe state enable bar
B29	FSSTATEL	Fail-safe state low-side
B30	FSSATEH	Fail-safe state high-side
B31	VSUP	12 V voltage supply (low voltage domain)
B32	GNDP	Ground connection (low voltage domain)

4.2.3 Test points

All test points are clearly marked on the board. The following figure shows the location of various test points.

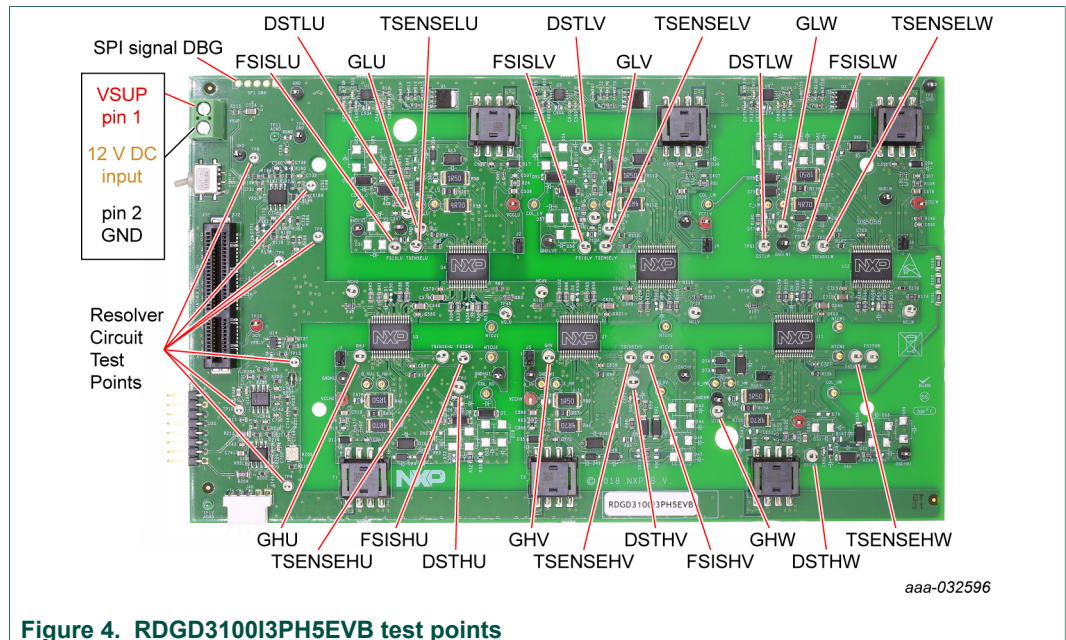

Figure 4. RDGD3100I3PH5EVB test points

Test point name	Function
DCV	Micro DC voltage
DSTHU	DESAT high-side U phase V_{CE} desaturation connected to DESAT pin circuitry
DSTHV	DESAT high-side V phase V_{CE} desaturation connected to DESAT pin circuitry
DSTHW	DESAT high-side W phase V_{CE} desaturation connected to DESAT pin circuitry
DSTLU	DESAT low-side U phase V_{CE} desaturation connected to DESAT pin circuitry
DSTLV	DESAT low-side V phase V_{CE} desaturation connected to DESAT pin circuitry
DSTLW	DESAT low-side W phase V_{CE} desaturation connected to DESAT pin circuitry
FSISHU	Not used – for test purposes only
FSISHV	Not used – for test purposes only
FSISLU	Not used – for test purposes only
FSISLV	Not used – for test purposes only

Test point name	Function
FSISLW	Not used – for test purposes only
GHU	Gate high-side U phase which is the charging pin of IGBT gate
GHV	Gate high-side V phase which is the charging pin of IGBT gate
GHW	Gate high-side W phase which is the charging pin of IGBT gate
GLU	Gate low-side U phase which is the charging pin of IGBT gate
GLV	Gate low-side V phase which is the charging pin of IGBT gate
GLW	Gate low-side W phase which is the charging pin of IGBT gate
NCLU – NCHW	Not used – for test purposes only
Resolver circuit	Test points for internal signals of resolver circuit (see schematic for more information)
SPI DBG	SPI signal port for analyzing SPI signals (see schematic for signals)
TSENSEHU	TSENSE high-side U phase connected to NTC temperature sense
TSENSEHV	TSENSE high-side V phase connected to NTC temperature sense
TSENSEHW	TSENSE high-side W phase connected to NTC temperature sense
TSENSELU	TSENSE low-side U phase
TSENSELV	TSENSE low-side V phase
TSENSELW	TSENSE low-side W phase

4.2.4 Indicators

The RDGD3100I3PH5EVB evaluation board contains LEDs as visual indicators on the board.

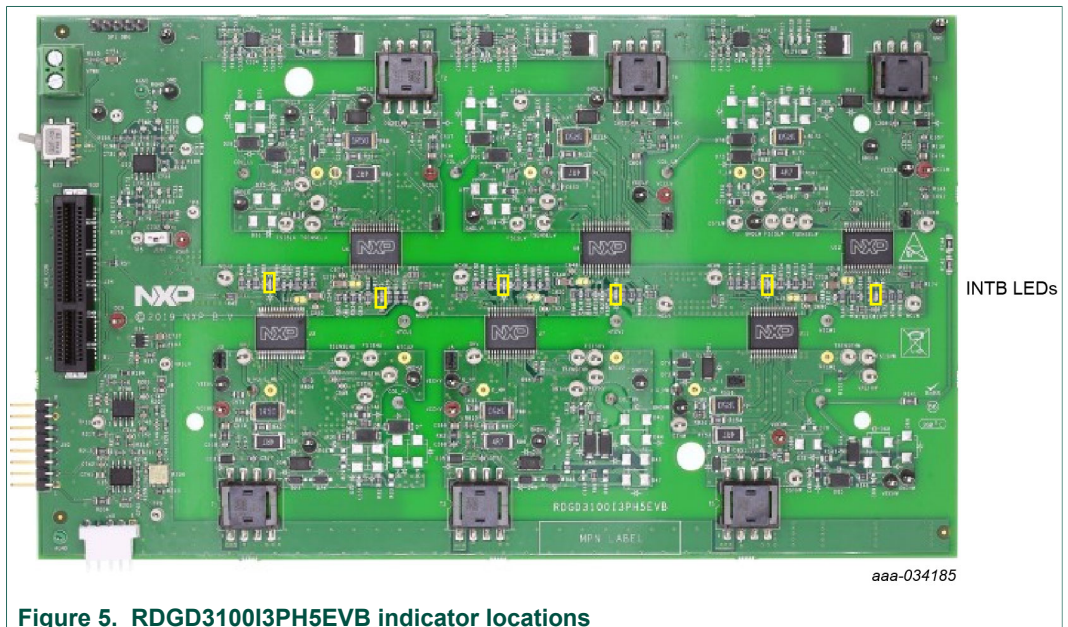

Table 2. RDGD3100I3PH5EVB indicator descriptions

Name	Description
INTB LEDs	Indicate a GD3100 interrupt has occurred on that gate drive device

4.2.5 Connectors

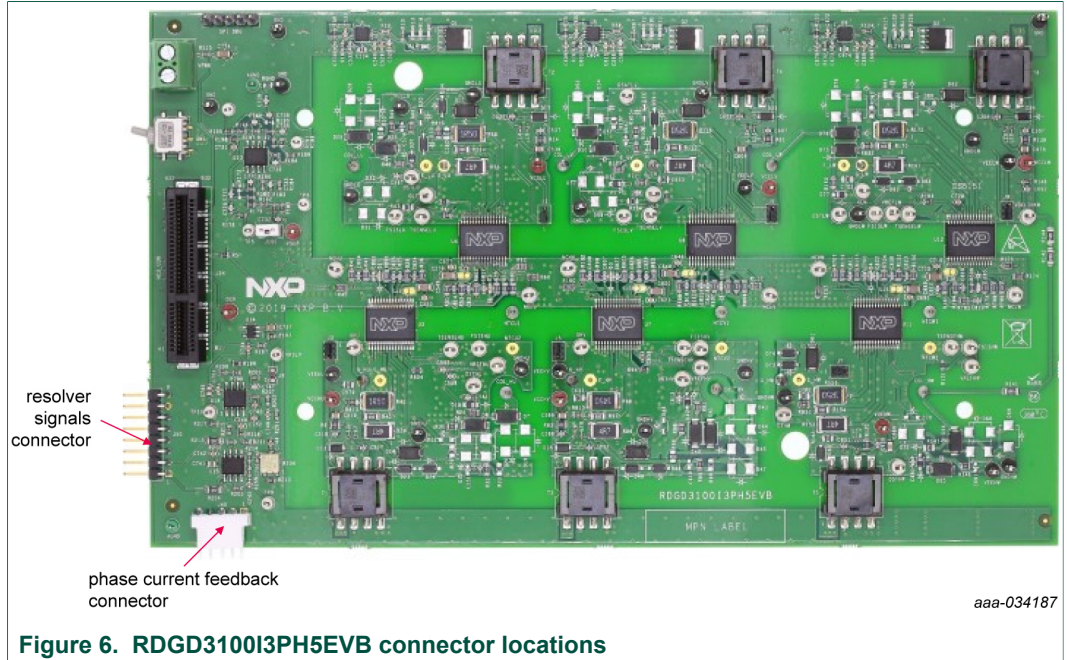

Figure 6. RDGD3100I3PH5EVB connector locations

Table 3. RDGD3100I3PH5EVB connector descriptions

Name	Description
Phase current feedback connector	Current feedback connections from U, V, and W phases
Resolver signals connector	Resolver excitation signals (see schematic for more information)

4.2.6 Power supply and jumper configuration

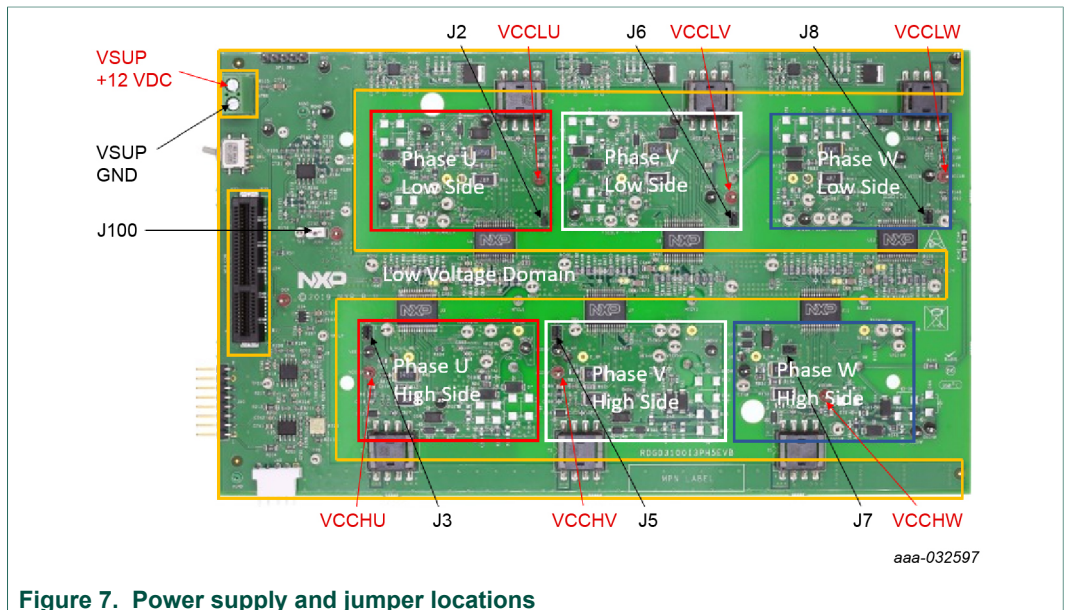

Figure 7. Power supply and jumper locations

RDGD3100I3PH5EVB three-phase inverter reference design

Name	Function
J2	Low-side phase U VEE select. Negative voltage supply for gate of IGBT. <ul style="list-style-type: none"> 1-2 negative VEE voltage (default) typically -5.0 V to -8.0 V 2-3 VEE voltage equal to GND2
J3	High-side phase U VEE select. Negative voltage supply for gate of IGBT. <ul style="list-style-type: none"> 1-2 negative VEE voltage (default) typically -5.0 V to -8.0 V 2-3 VEE voltage equal to GND2
J5	High-side phase V VEE select. Negative voltage supply for gate of IGBT. <ul style="list-style-type: none"> 1-2 negative VEE voltage (default) typically -5.0 V to -8.0 V 2-3 VEE voltage equal to GND2
J6	Low-side phase V VEE select. Negative voltage supply for gate of IGBT. <ul style="list-style-type: none"> 1-2 negative VEE voltage (default) typically -5.0 V to -8.0 V 2-3 VEE voltage equal to GND2
J7	High-side phase W VEE select. Negative voltage supply for gate of IGBT. <ul style="list-style-type: none"> 1-2 negative VEE voltage (default) typically -5.0 V to -8.0 V 2-3 VEE voltage equal to GND2
J8	Low-side phase W VEE select. Negative voltage supply for gate of IGBT. <ul style="list-style-type: none"> 1-2 negative VEE voltage (default) typically -5.0 V to -8.0 V 2-3 VEE voltage equal to GND2
J100	Used for routing DC voltage from VSUP connection terminal
SJ1 to SJ6	Solder jumpers used for 5.0 V operation connecting VSUP to VDD on each gate drive device
SW1	Not used (internal purposes only)
VCCHU	High-side phase U VCC voltage test point Isolated positive voltage supply (15 V to 18 V)
VCCHV	High-side phase V VCC voltage test point Isolated positive voltage supply (15 V to 18 V)
VCCHW	High-side phase W VCC voltage test point Isolated positive voltage supply (15 V to 18 V)
VCCLU	Low-side phase U VCC voltage test point Isolated positive voltage supply (15 V to 18 V)
VCCLV	Low-side phase V VCC voltage test point Isolated positive voltage supply (15 V to 18 V)
VCCLW	Low-side phase W VCC voltage test point Isolated positive voltage supply (15 V to 18 V)
VSUP +12 V DC	VSUP low voltage positive supply connection (+12 V DC)
VSUP GND	VSUP low voltage supply ground connection (GND1)

4.2.7 Gate drive resistors

- RGH - gate high resistor in series with the GH pin at the output of the GD3100 high-side driver and IGBT gate that controls the turn on current for IGBT gate.
- RGL - gate low resistor in series with the GL pin at the output of the GD3100 low-side driver and IGBT gate that controls the turn off current for IGBT gate.
- RAMC - series resistor between IGBT gate and AMC input pin of the GD3100 high-side/low-side driver for gate sensing and Active Miller clamping.

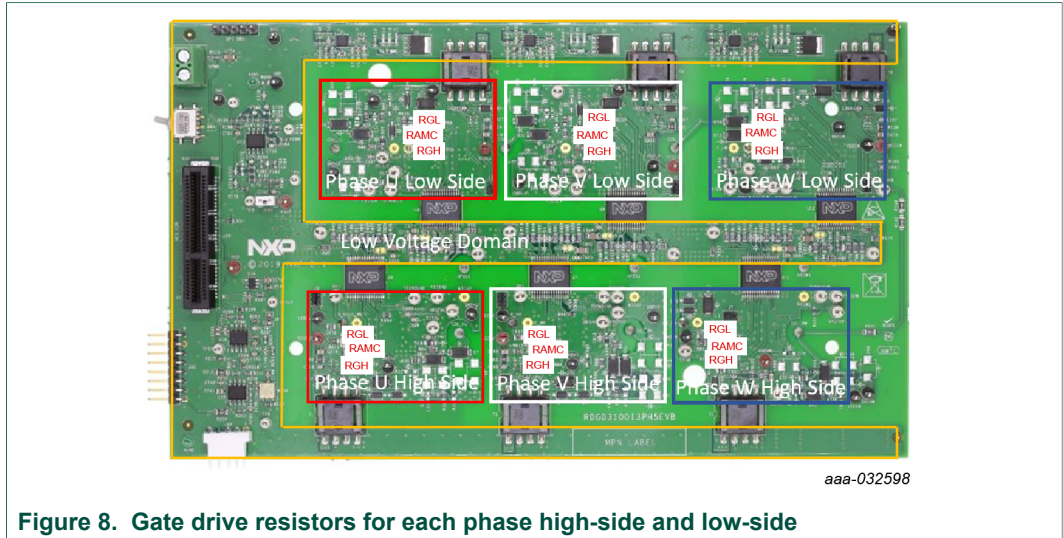

Figure 8. Gate drive resistors for each phase high-side and low-side

4.2.8 IGBT pin connections

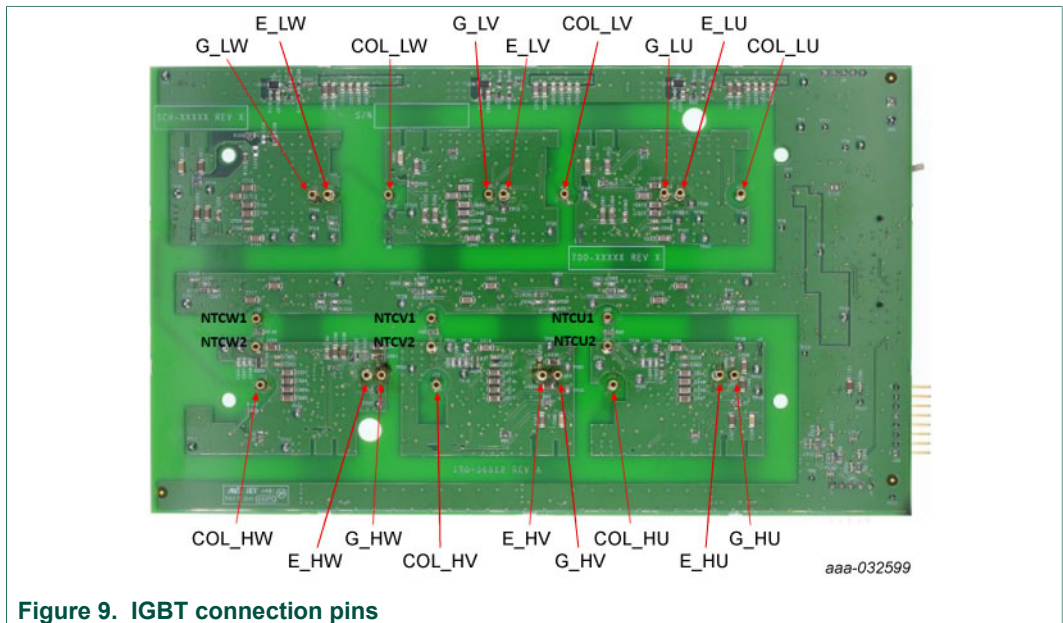

Figure 9. IGBT connection pins

Connection name	Pin description
COL_HU	Collector high-side U phase
COL_HV	Collector high-side V phase
COL_HW	Collector high-side W phase
COL_LU	Collector low-side U phase
COL_LV	Collector low-side V phase
COL_LW	Collector low-side W phase
E_HU	Emitter high-side U phase
E_HV	Emitter high-side V phase
E_HW	Emitter high-side W phase

Connection name	Pin description
E_LU	Emitter low-side U phase
E_LV	Emitter low-side V phase
E_LW	Emitter low-side W phase
G_HU	Gate high-side U phase
G_HV	Gate high-side V phase
G_HW	Gate high-side W phase
G_LU	Gate low-side U phase
G_LV	Gate low-side V phase
G_LW	Gate low-side W phase
NTC1	Negative temperature coefficient resistor connections 1 U, V, and W phase
NTC2	Negative temperature coefficient resistor connections 2 U, V, and W phase

4.3 Schematic, board layout, and bill of materials

The schematic, board layout, and bill of materials for the RDGD3100I3PH5EVB reference design are available at <http://www.nxp.com/RDGD3100I3PH5EVB>.

5 Configuring the hardware for startup

Figure 10 presents a typical hardware configuration.

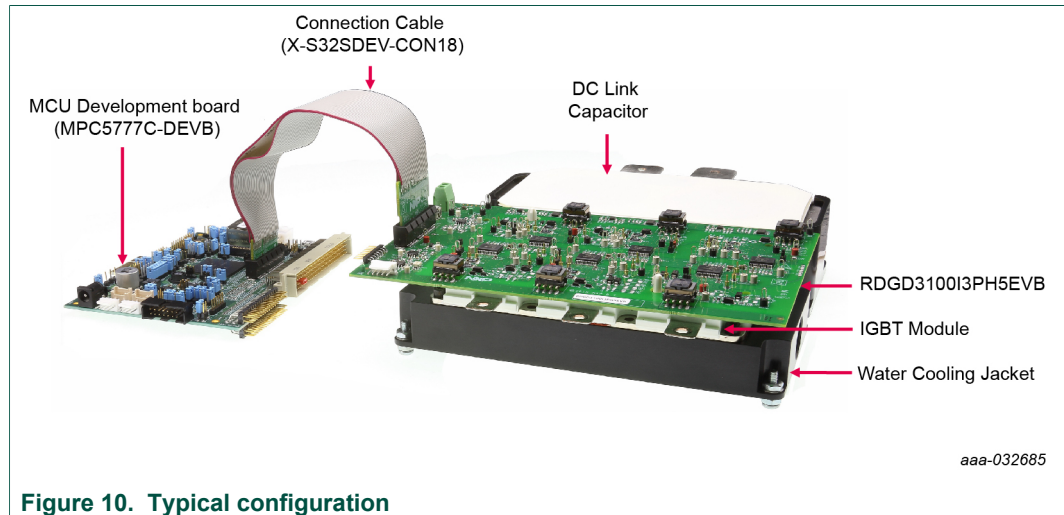

Figure 10. Typical configuration

To configure the hardware as illustrated in Figure 10, complete the following procedure:

1. Assemble IGBT module with water cooling jacket if desired and properly attach to DC Link capacitor positive and negative high-voltage supply connections across U, V, and W phases.
2. Attach RDGD3100I3PH5EVB to the IGBT module. Ensure that all board socket connection pins are properly seated onto the IGBT pin connections. The board socket pins are intended for easy attachment and deattachment to IGBT module without damaging IGBT connection pins.
3. Connect motor:

- a. Connect output of IGBT module each phase U, V, and W to each of the respective U, V, W connections on the desired three-phase motor.
 - b. For running motor in closed loop motor control, connect resolver signals from motor resolver connection to the resolver pin connections on the RDGD3100I3PH5EVB. See schematics for J50 header signal connections on the RDGD3100I3PH5EVB board.
 - c. For running motor in closed loop motor control, connect current sensors from each phase U, V, and W (current sensors are not included with RDGD3100I3PH5EVB) and connect the respective signals from the current sensors to the phase current feedback pin connections of the RDGD3100I3PH5EVB. See schematics for J40 header signal connections on the RDGD3100I3PH5EVB board.
4. Connect DC power:
 - a. Connect a low voltage DC power supply to the RDGD3100I3PH5EVB at the VSUP connection terminal (12 V DC with a minimum 1.0 A supply). Ensure that J100 jumper is in place.
 - b. Connect a low voltage DC supply to MCU controller board and connect USB cable from MCU controller to desired computer for software driven motor control.
 - c. Connect high voltage/high current DC supply (use recommended voltage and current for desired motor) to positive and negative connections on DC Link capacitor to supply three-phase motor DC link voltage.
 5. Attach 2x32 PCIe cable (X-S32SDEV-CON18) supplied with kit to the RDGD3100I3PH5EVB and MCU controller board such as the MPC5777C-DEVB. This cable is keyed and is compatible with interface port on MPC5777C-DEVB.

6 Installing and configuring software and tools

6.1 Software development tools

NXP has software development tools available for use with the NXP MPC5777C development board (DEVB). The development board is intended to provide a platform for easy customer evaluation of the MPC5777C microcontroller and to facilitate hardware and software development. The development board can be used for Powertrain/ Inverters/BMS/Automotive ethernet, etc. The latest product information is available at www.nxp.com/MPC5777C.

List of Development software:

- S32S Design Studio IDE for power architecture:
The **S32S design studio for power architecture** IDE installed on a Windows PC workstation enables editing, compiling and debugging of source code designs. SDK supports several devices including MPC5777C. For more information, refer to S32DS-PA SDK for power architectures at <http://www.nxp.com>.
- Automotive Math and Motor Control Library (AMMCL):
Automotive Math and Motor Control Library (AMMCL) is a precompiled software library containing the building blocks for a wide range of motor control and general mathematical applications. For more information and to download AMMCL, refer to Automotive Math and Motor Control Library Set for MPC577xC at <http://www.nxp.com>.
- FreeMaster 2.0 runtime debugging tool:
FreeMASTER runtime debugging tool is a separate download and can also be used in conjunction with the MCU code developed with S32DS as a user-friendly real-time debug monitor, graphical control panel, and data visualization tool for application

development and information management. See FreeMASTER runtime debugging tool at <http://www.nxp.com>.

- Motor Control Application Tuning (MCAT):
Motor Control Application Tuning (MCAT) is a FreeMASTER plug-in tool intended for the development of PMSM FOC and BLDC motor control applications. For more information and to download MCAT, refer to MCAT at <http://www.nxp.com>.
- Example code, GD3100 Device Driver notes and GD3100 Device Driver Reference notes:
GD3100 Device Driver example code REV1.1 provides a basis to get started and begin software development for the desired motor control. See GD3100 Device Driver Example Code (REV 1.1 or later) at <http://www.nxp.com>.

7 References

- [1] **RDGD3100I3PH5EVB** — detailed information on this board, including documentation, downloads, and software and tools
<http://www.nxp.com/RDGD3100I3PH5EVB>
- [2] **GD3100** — product information on Advanced single-channel gate driver for Insulated Gate Bipolar Transistors (IGBTs)
<http://www.nxp.com/GD3100>
- [3] **MPC5777C** — ultra-reliable MCU for automotive and industrial engine management
<http://www.nxp.com/MPC5777C>
- [4] **MPC5744P** — ultra-reliable MCU for automotive and industrial safety applications
<https://www.nxp.com/MPC574xP>

8 Revision history

Revision history

Rev	Date	Description
v.1	20190528	Initial version

9 Legal information

9.1 Definitions

Draft — The document is a draft version only. The content is still under internal review and subject to formal approval, which may result in modifications or additions. NXP Semiconductors does not give any representations or warranties as to the accuracy or completeness of information included herein and shall have no liability for the consequences of use of such information.

9.2 Disclaimers

Limited warranty and liability — Information in this document is believed to be accurate and reliable. However, NXP Semiconductors does not give any representations or warranties, expressed or implied, as to the accuracy or completeness of such information and shall have no liability for the consequences of use of such information. NXP Semiconductors takes no responsibility for the content in this document if provided by an information source outside of NXP Semiconductors. In no event shall NXP Semiconductors be liable for any indirect, incidental, punitive, special or consequential damages (including - without limitation - lost profits, lost savings, business interruption, costs related to the removal or replacement of any products or rework charges) whether or not such damages are based on tort (including negligence), warranty, breach of contract or any other legal theory. Notwithstanding any damages that customer might incur for any reason whatsoever, NXP Semiconductors' aggregate and cumulative liability towards customer for the products described herein shall be limited in accordance with the Terms and conditions of commercial sale of NXP Semiconductors.

Right to make changes — NXP Semiconductors reserves the right to make changes to information published in this document, including without limitation specifications and product descriptions, at any time and without notice. This document supersedes and replaces all information supplied prior to the publication hereof.

Applications — Applications that are described herein for any of these products are for illustrative purposes only. NXP Semiconductors makes no representation or warranty that such applications will be suitable for the specified use without further testing or modification. Customers are responsible for the design and operation of their applications and products using NXP Semiconductors products, and NXP Semiconductors accepts no liability for any assistance with applications or customer product design. It is customer's sole responsibility to determine whether the NXP Semiconductors product is suitable and fit for the customer's applications and products planned, as well as for the planned application and use of customer's third party customer(s). Customers should provide appropriate design and operating safeguards to minimize the risks associated with their applications and products. NXP Semiconductors does not accept any liability related to any default, damage, costs or problem which is based on any weakness or default in the customer's applications or products, or the application or use by customer's third party customer(s). Customer is responsible for doing all necessary testing for the customer's applications and products using NXP Semiconductors products in order to avoid a

default of the applications and the products or of the application or use by customer's third party customer(s). NXP does not accept any liability in this respect.

Suitability for use in automotive applications — This NXP Semiconductors product has been qualified for use in automotive applications. Unless otherwise agreed in writing, the product is not designed, authorized or warranted to be suitable for use in life support, life-critical or safety-critical systems or equipment, nor in applications where failure or malfunction of an NXP Semiconductors product can reasonably be expected to result in personal injury, death or severe property or environmental damage. NXP Semiconductors and its suppliers accept no liability for inclusion and/or use of NXP Semiconductors products in such equipment or applications and therefore such inclusion and/or use is at the customer's own risk.

Export control — This document as well as the item(s) described herein may be subject to export control regulations. Export might require a prior authorization from competent authorities.

Evaluation products — This product is provided on an "as is" and "with all faults" basis for evaluation purposes only. NXP Semiconductors, its affiliates and their suppliers expressly disclaim all warranties, whether express, implied or statutory, including but not limited to the implied warranties of non-infringement, merchantability and fitness for a particular purpose. The entire risk as to the quality, or arising out of the use or performance, of this product remains with customer. In no event shall NXP Semiconductors, its affiliates or their suppliers be liable to customer for any special, indirect, consequential, punitive or incidental damages (including without limitation damages for loss of business, business interruption, loss of use, loss of data or information, and the like) arising out of the use of or inability to use the product, whether or not based on tort (including negligence), strict liability, breach of contract, breach of warranty or any other theory, even if advised of the possibility of such damages. Notwithstanding any damages that customer might incur for any reason whatsoever (including without limitation, all damages referenced above and all direct or general damages), the entire liability of NXP Semiconductors, its affiliates and their suppliers and customer's exclusive remedy for all of the foregoing shall be limited to actual damages incurred by customer based on reasonable reliance up to the greater of the amount actually paid by customer for the product or five dollars (US\$5.00). The foregoing limitations, exclusions and disclaimers shall apply to the maximum extent permitted by applicable law, even if any remedy fails of its essential purpose.

Translations — A non-English (translated) version of a document is for reference only. The English version shall prevail in case of any discrepancy between the translated and English versions.

9.3 Trademarks

Notice: All referenced brands, product names, service names and trademarks are the property of their respective owners.

NXP — is a trademark of NXP B.V.

SMARTMOS — is a trademark of NXP B.V.

Tables

Tab. 1.	PCIe connector pin definitions	6	Tab. 3.	RDGD3100I3PH5EVB connector descriptions	10
Tab. 2.	RDGD3100I3PH5EVB indicator descriptions	9			

Figures

Fig. 1.	RDGD3100I3PH5EVB	1	Fig. 6.	RDGD3100I3PH5EVB connector locations	10
Fig. 2.	RDGD3100I3PH5EVB three-phase inverter board voltage domains and interfaces	4	Fig. 7.	Power supply and jumper locations	10
Fig. 3.	Gate driver pinout and board interface connection PCIe 2×32	6	Fig. 8.	Gate drive resistors for each phase high-side and low-side	12
Fig. 4.	RDGD3100I3PH5EVB test points	8	Fig. 9.	IGBT connection pins	12
Fig. 5.	RDGD3100I3PH5EVB indicator locations	9	Fig. 10.	Typical configuration	13

Contents

1	Introduction	2
2	Finding kit resources and information on the NXP web site	2
2.1	Collaborate in the NXP community	2
3	Getting started	2
3.1	Kit contents	3
3.2	Additional hardware	3
3.3	Windows PC workstation	3
3.4	Software	3
4	Getting to know the hardware	3
4.1	Kit overview	3
4.1.1	RDGD3100I3PH5EVB features	3
4.1.2	Voltage domains, GD3100 pinout, logic header, and IGBT pinout	4
4.2	Featured components	4
4.2.1	Advanced IGBT gate driver	4
4.2.1.1	General description	4
4.2.1.2	GD3100 features	5
4.2.2	GD3100 pinout and MCU interface pinout	5
4.2.3	Test points	8
4.2.4	Indicators	9
4.2.5	Connectors	10
4.2.6	Power supply and jumper configuration	10
4.2.7	Gate drive resistors	11
4.2.8	IGBT pin connections	12
4.3	Schematic, board layout, and bill of materials ..	13
5	Configuring the hardware for startup	13
6	Installing and configuring software and tools	14
6.1	Software development tools	14
7	References	15
8	Revision history	15
9	Legal information	16

Please be aware that important notices concerning this document and the product(s) described herein, have been included in section 'Legal information'.

© NXP B.V. 2019.

All rights reserved.

For more information, please visit: <http://www.nxp.com>

For sales office addresses, please send an email to: salesaddresses@nxp.com

Date of release: 28 May 2019
Document identifier: UM11178