

REVISIONS

P	LTR	DESCRIPTION	DATE	DWN	APVD
	A	RELEASED FOR PRODUCTION	10FEB2023	DM	CB
	AI	ADDING PRODUCT DATA	07MAR2023	DM	CB

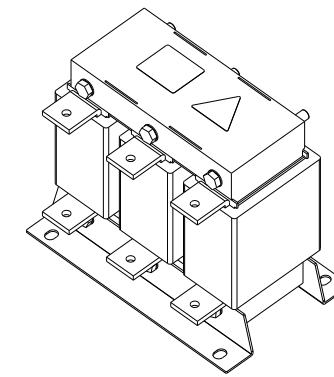
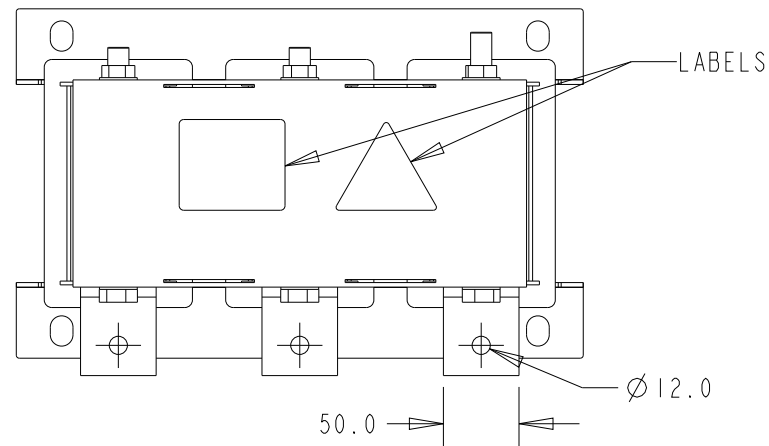

NOMINAL OPERATING VOLTAGE (VAC)	3x 380 to 480
RATED OPERATING VOLTAGE (VAC)	3x 340 to 530
FREQUENCY (Hz)	50 / 60
RATED CURRENT (AMPS)	700.00
OP. TEMP. RANGE @ RATED CURRENT	-45°C to +45°C
RATED POWER @ 400VAC (kW)	436.48
RATED POWER @ 400VAC (HP)	585.09
IMPEDANCE @ 400VAC (%)	4
INDUCTANCE, NOMINAL (mH)	0.040
POWER OVERLOAD, 1 MINUTE EVERY HOUR	1.6
VOLTAGE WITHSTAND 1 MINUTE (kVAC)	2
POLLUTION DEGREE	PD2
COOLING	NATURAL
PROTECTION CLASS	IP00
INSULATION CLASS	N
STORAGE TEMPERATURE RANGE (°C)	-45°C to +100°C
CLIMATIC CATEGORY	45/100/21
DESIGN CORRESPONDING TO	EN61558-2-20, EN60076-6, UL61800-5-1

SAFETY ORGANIZATIONS

UL RECOGNIZED AS PER UL 508 HARDWARE CERTIFICATION

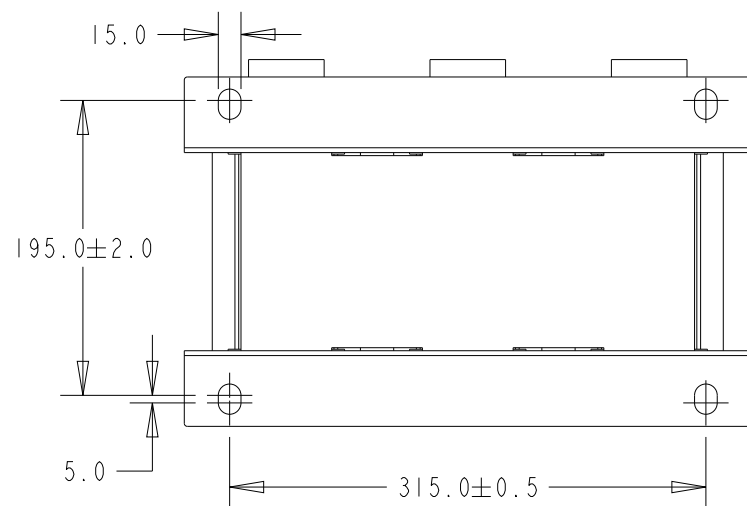
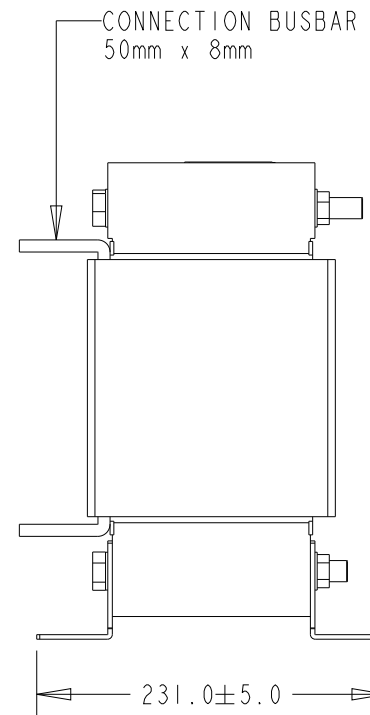
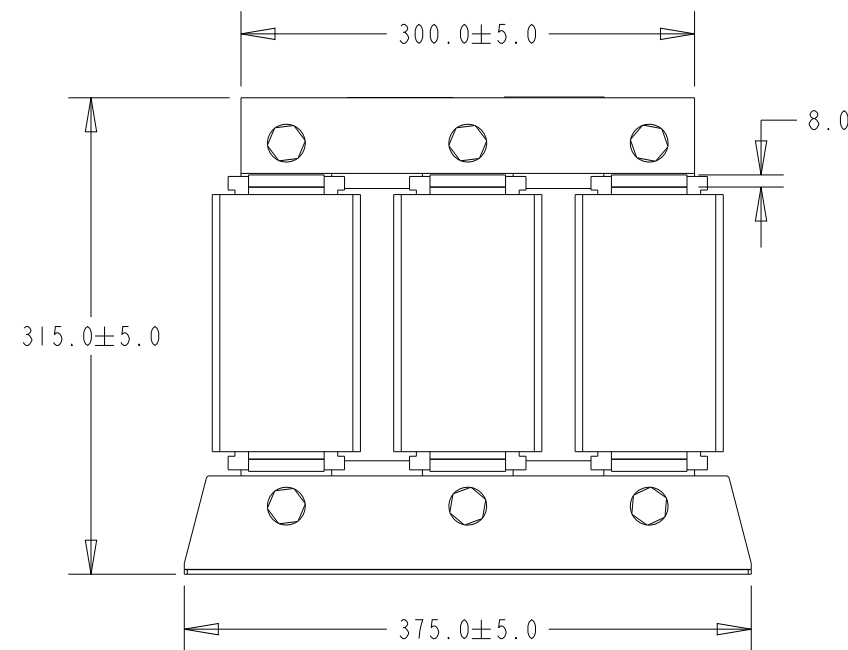

DE-RATING FORMULAE FOR OPERATION ABOVE 45°C AMBIENT CONDITIONS:

$$I = I_n \sqrt{\frac{100 - T_{a\ new}}{100 - 45}}$$

TYPICAL CIRCUIT DIAGRAM

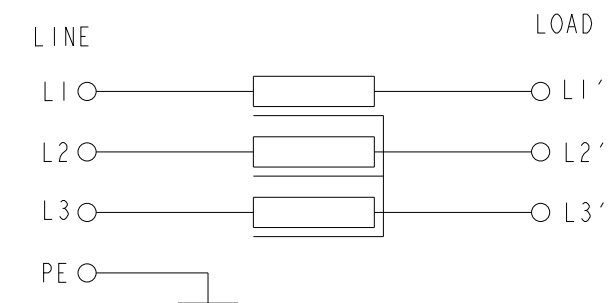

RoHS COMPLIANT

THIS DRAWING IS A CONTROLLED DOCUMENT.		DWN C. BOLLE 07OCT2022	 TE Connectivity				
DIMENSIONS: mm		CHK C. BOLLE 07OCT2022					
TOLERANCES UNLESS OTHERWISE SPECIFIED:		APVD L. RAJ 07OCT2022	NAME RPO-3-700 THREE LINE REACTOR				
<ul style="list-style-type: none"> 0 PLC ±- 1 PLC ±0.1 2 PLC ±0.01 3 PLC ±0.001 4 PLC ±0.0001 ANGLES ±- 		PRODUCT SPEC -	APPLICATION SPEC -				
MATERIAL -		FINISH -	WEIGHT -	SIZE A3	CAGE CODE 00779	DRAWING NO C=5-2432409-3	RESTRICTED TO -
CUSTOMER DRAWING			SCALE 1:5	SHEET 1	OF 1	REV A1	