

SR-1000 DIN Rail Media Converters

 perle.com/products/media-converters/sr-1000-din-rail-copper-fiber-converters.shtml

Gigabit Copper to Fiber Converters

- 1000Base-T to 1000Base-X Fiber Media Converters
- Link copper to multimode or single mode fiber
- Dual fiber ST/SC or Single fiber SC connectors
- Extend network distances up to 160km
- Advanced Features: Link Pass-Through, Far-End Fault, Auto-MDIX
- Triple Power Input: Dual Terminal block power connector & T-Bus



Perle **SR-1000 DIN Rail Media Converters** transparently connect UTP copper to fiber. These Gigabit Media Converters provide an economical path to:

- enable Gigabit speeds across a multimode fiber link up to 2km in length (learn more)
- extend the distance of an existing network by linking CAT5/6/7 cabling to multimode or single mode fiber
- extend the life of non-fiber based equipment by enabling data transmission from 1000Base-T devices over gigabit fiber
- extend the distance between two copper-based devices or networks
- protect Ethernet data from EMI noise and interference by inter-connecting your copper-Ethernet devices over fiber in industrial plants.

Some SR-1000 Media Converters are also available with an SFP slot or support for -40C to +75C (-40F to +167F) extended operating temperatures.

Network Administrators can rest assured with Perle's advanced features such as Auto-Negotiation, Auto-MDIX, Link Pass-Through, Far End Fault, and Pause which make the end to end link completely transparent. This allows for more efficient troubleshooting and less on-site maintenance. These cost and time saving features, along with a lifetime warranty and free worldwide technical support, make **SR-1000 Gigabit Media Converters** the smart choice for IT professionals.

SR-1000 Fiber Media Converter Features: 1000Base-T to 1000Base-X

DIN Rail Enclosure	Easily mount on a DIN rail or inside distribution boxes using native DIN Rail enclosure with grounding clip. No need for add-on brackets.
--------------------	---

Auto-Negotiation	The media converter supports auto negotiation. The 1000Base-X fiber interface negotiates according to 802.3 clause 37. The 1000Base-T negotiates according to 802.3 clause 28 and 40. The 1000Base-X will link up with its partner after the highest common denominator (HCD) is reached and the copper has linked up with its partner. The 1000Base-X will continue to cycle through negotiation transmitting a remote fault of offline (provided this is enabled through the switch setting) until the copper is linked up and the HCDs match.
------------------	--

	The media converter supports auto-negotiation of full duplex, half duplex, remote fault, full duplex pause, asymmetric pause and Auto MDI-X.
--	--

Auto-MDIX with Skew Correction	Auto-MDIX (automatic medium-dependant interface crossover) detects the signaling on the 1000Base-T interface to determine the type of cable connected (straight-through or crossover) and automatically configures the connection when enabled. The media converter can also correct for wires swapped within a pair. The media converter will adjust for up to 64ns of delay skew between the 1000Base-T pairs.
Smart Link Pass-Through	When Smart Link Pass-Through mode is enable, the Ethernet copper port will reflect the state of the Ethernet fiber media converter port. This feature can be used whether fiber auto-negotiation is enabled or disabled.
Fiber Fault Alert	With Fiber Fault Alert the state of the 1000Base-X receiver is passed to the 1000Base-X transmitter. This provides fault notification to the partner device attached to the 1000Base-X interface of the media converter. If the 1000Base-X transmitter is off, as a result of this fault, it will be turned on periodically to allow the condition to clear should the partner device on the 1000Base-X be using a similar technique. This eliminates the possibility of lockouts that occur with some media converters. Applies only when fiber auto-negotiation is disabled.
Pause (IEEE 802.3x)	Pause signaling is an IEEE feature that temporarily suspends data transmission between two devices in the event that one of the devices becomes overwhelmed. The media converter supports pause negotiation on the 1000Base-T copper connection and 1000Base-X fiber connection.
Duplex	Full and half duplex operation supported.
Jumbo Packets	Transparent to jumbo packets up to 10KB.
VLAN	Transparent to VLAN tagged packets.
Remote LoopBack	Capable of performing a loopback on the 1000Base-X fiber interface.

Hardware Specifications: SR-1000 Media Converters

Power	
Input Supply Voltage	Triple voltage 12 / 24 / 48 VDC (9.6 – 60 VDC) input supporting: a) 2 x Terminal Block power input and b) 1 x T-Bus power input
Current	0.09 A (@ 24VDC)
Power Consumption	2.16 watts (@ 24VDC)
Power Connector	Dual input Terminal Block and/or T-Bus
Indicators	
Power / TST	This green LED is turned on when power is applied to the media converter. Otherwise it is off. The LED will blink fast/slow when in Loopback test mode or hardware error.

Fiber link on / Receive activity (LKF) On: Fiber link present. Blinking slowly: Fiber link disabled because of copper link loss. Blinking quickly: Fiber link present and receiving data. Off: No fiber link present

Copper link on / Receive activity (LKC) On: Fiber link present. Blinking slowly: Fiber link disabled because of copper link loss. Blinking quickly: Fiber link present and receiving data. Off: No fiber link present

Switches - accessible by sliding the chassis open



Auto-Negotiation Auto (Default-Up): In this mode of operation the media converter will negotiate Ethernet parameters on both the copper and the fiber connection. This will ensure the most optimal connection parameters will be in effect. If connecting to another Perle Gigabit Media Converter, this parameter should be set to Auto.

Off: The fiber Negotiation should only be turned off, if the fiber link partner does not support fiber link negotiations

Smart Link Pass-Through Standard Mode (Default-Up): In this mode, if Fiber Negotiation is set to OFF, the links on the fiber and copper sides can be brought up and down independently of each other. A loss of link on either the fiber link or copper link can take place without affecting the other connection. However, if the Fiber Negotiation (switch 2) is set to Auto, then a loss of link on the copper side will result in a loss of link on the fiber side but not vice versa.

Smart Link Pass-Through (Down): In this mode, the link state on one connection is directly reflected through the media converter to the other connection. If link is lost on one of the connections, then the other link will be brought down by the media converter.

Pause Enabled (Default-Up): In this mode, when Fiber Negotiation has been turned off, the media converter will use this setting for its Ethernet parameter negotiation on the copper connection. With this Pause switch in the Enabled position, the media converter will advertise support for Symmetrical and Asymmetrical Pause.

Disabled: The media converter will not advertise support for the Pause feature.

Loopback Disabled (Default-Up): The loopback feature is disabled. This is the normal position for regular operation. The switch must be set to this position for data to pass through the media converter.

Enabled: This is a test mode. All data received on the receive (RX) fiber connection is looped back to the transmit (TX) fiber connection. The state of the copper is not relevant and no data or link status is passed through to the copper side.

Fiber Fault Alert (FFA)	<p>Enabled (Default-Up): In this mode, when Fiber negotiation is turned on, if the media converter detects a loss of fiber signal on the fiber receiver it will immediately disable its fiber transmitter signal. This notifies the fiber link partner that an error condition exists on the fiber connection. If the remote media converter is set up for FFA Enabled and the local media converter is set up with Smart Link Pass-Through, a loss of fiber link on either the transmit or receive line will be passed through to the local copper connection to notify the connected device. If the media converter has been set to Smart Link Pass-Through mode, the effect will be the same as FFA since the link loss on the fiber receiver will result in bringing down the copper link, which will in turn cause the transmit fiber link to be brought down.</p> <p>Disabled: In this mode, the media converter will not monitor for fiber fault.</p>
-------------------------	--

Duplex Mode	<p>Auto (Default-Up): In this mode, when Fiber Negotiation has been turned off, the media converter will use this Duplex setting for its Ethernet parameter negotiation on the copper connection. In the Auto position, the media converter will advertise support for both Full and Half Duplex mode. The resultant negotiation will provide the most optimum connection.</p> <p>Half: In this mode, the media converter will force the negotiation to Half Duplex mode</p>
-------------	--

Cables and Connectors

1000Base-T	RJ45 connector, 4 pair CAT 5 (UTP or STP) or better cable
Fixed Fiber	Dual multimode or single mode (Duplex) fiber - SC, ST Single strand fiber (Simplex) – SC
Magnetic Isolation	1.5kv
Fiber Optic Cable	Multimode: 62.5 / 125, 50/125, 85/125, 100/140 micron Single Mode: 9/125 micron (ITU-T 625)

Filtering

Filtering	1024 MAC Addresses
-----------	--------------------

Frame Specifications

Buffer	512 Kbits frame buffer memory
Size	Maximum frame size of 10,240 bytes

Packet Transmission Characteristics

Bit Error Rate (BER)	<10 ⁻¹²
----------------------	--------------------

Environmental Specifications

Operating Temperature	-10 C to 60 C (14 F to 140 F)
Storage Temperature	-25 C to 70 C (-13 F to 158 F)

Operating Humidity	5% to 90% non-condensing
Storage Humidity	5% to 95% non-condensing
Operating Altitude	Up to 3,048 meters (10,000 feet)
Heat Output (BTU/HR)	7.37
MTBF (Hours)	695,274 (Calculation model based on MIL-HDBK-217-FN2 @ 30 °C)
Chassis	Molded plastic DIN Rail case with an IP20 ingress protection rating
Mounting	
Din Rail Kit	Native
Product Weight and Dimensions	
Weight	0.12 kg, 0.26 lbs
Dimensions	114 x 100 x 22.5mm, 4.5 x 3.9 x 0.88 inches
Packaging	
Shipping Weight	0.17 kg, 0.37 lbs
Shipping Dimensions	145 x 105 x 30 mm, 5.7 x 4.1 x 1.2 inches
Regulatory Approvals	
Emissions	FCC 47 Part 15 Class A, EN55032 (CISPR32) Class A EN55011 (CISPR11) ICES-003 EN61000-6-4 (Emissions for industrial environments) CISPR 32:2015/EN 55032:2015 (Class A) CISPR 24:2010/EN 55024:2010 EN61000-3-2
Immunity	EN55024 EN 61000-4-2 (ESD) EN 61000-4-3 (RS) EN 61000-4-4 (EFT) EN 61000-4-5 (Surge) EN 61000-4-6 (CS) EN 61000-4-8 (PFMF) EN 61000-4-11 IEC/EN 61000-6-2 (General Immunity for Industrial Environments)

Electrical Safety	IEC 62368-1(ed 2) EN 62368-1:2014
	CE
Laser Safety	EN 60825-1:2007
	Fiber optic transmitters on this device meet Class 1 Laser safety requirements per IEC-60825 FDA/CDRH standards and comply with 21CFR1040.10 and 21CFR1040.11.
Environmental	Reach, RoHS and WEEE Compliant
Other	ECCN: 5A991
	HTSUS Number: 8517.62.0020
	Perle Limited Lifetime Warranty

Extend distance between two UTP Gigabit Switches

Extend the network distance between two twisted pair Gigabit Switches

Two Gigabit Ethernet Media Converters can extend the distance between 1000Base-T Switches across a fiber link up to 160Km in length.

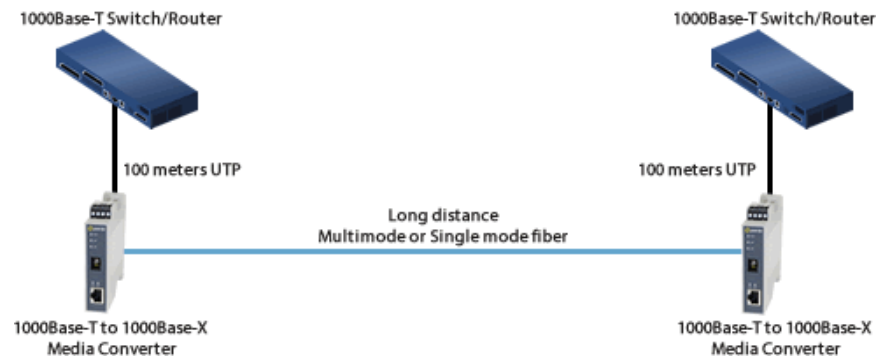

Gigabit UTP Switch to Fiber Switch

Interconnect a UTP Switch with a Fiber Switch

A media converter can interconnect a UTP copper based Switch port to a remote switch that has integrated fiber.

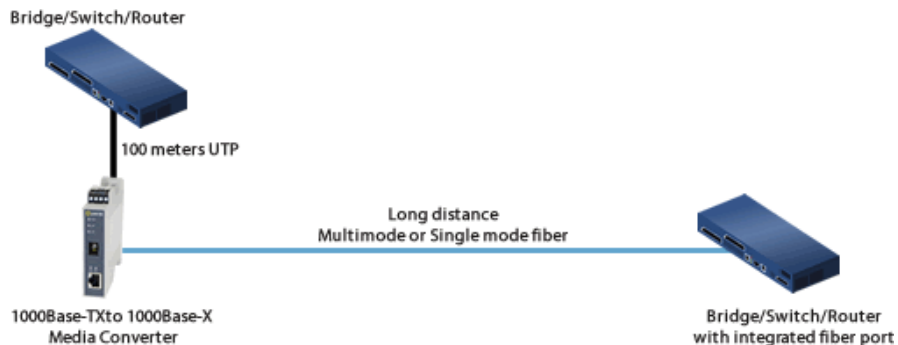

Switch to Gigabit Server

Extend the network distance between a Gigabit Switch and a Gigabit File Server

Two Gigabit Ethernet Media Converters can extend the distance between a 1000Base-T Switch and a Gigabit File Server across a fiber link up to 160Km in length.

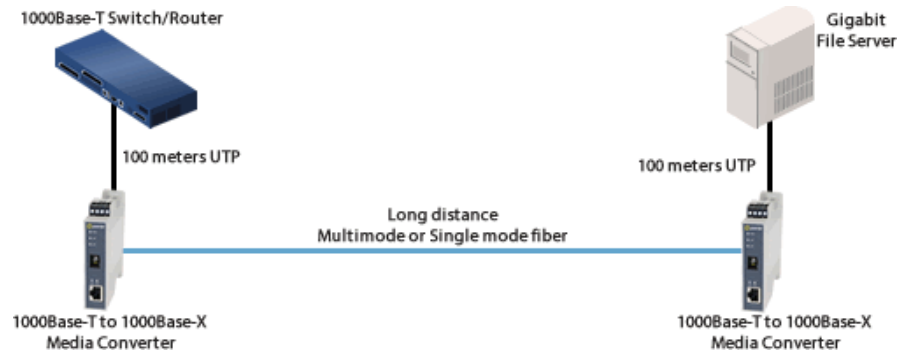

Direct Connect - Long Distance

Direct Connection between two remote devices

With a pair of Gigabit Media Converters two devices, such as file servers, can be connected up to 160km away across a fiber link.

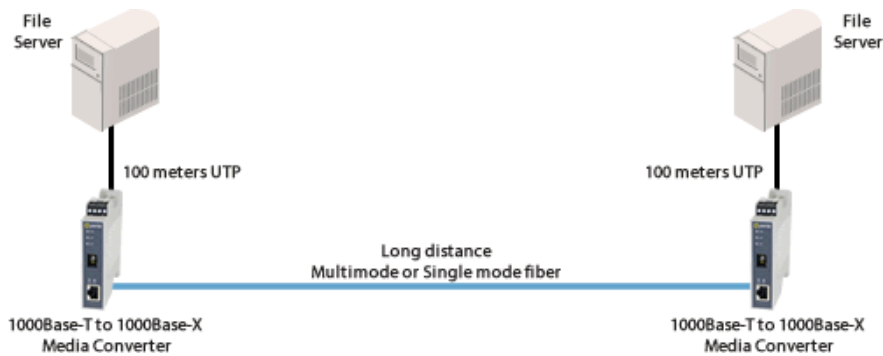

Gigabit Mode-Conditioning Adapters - More Distance

Extend Gigabit to 550m over 62.5 micron Multimode Fiber

Gigabit across 62.5 micron MMF cable is normally limited to 275 meters. By adding mode-conditioning adapters and 1000baseLX media converters you can extend the distance up to 550 meters on MMF cable plant.

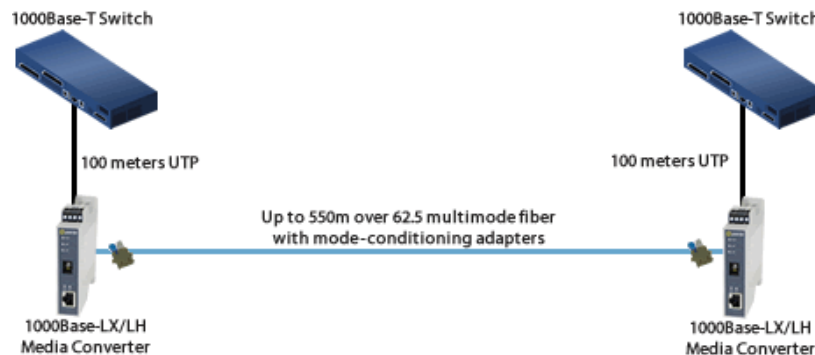

Gigabit Mode-Conditioning Adapters – 1000Base-LX

Installing Gigabit 1000Base-LX routers and switches into existing multimode cable plants

Using mode-conditioning adapters and a 1000Base-LX media converter, connect a copper based Gigabit Switch with a remote 1000base-LX switch/router over existing multimode cable plant.

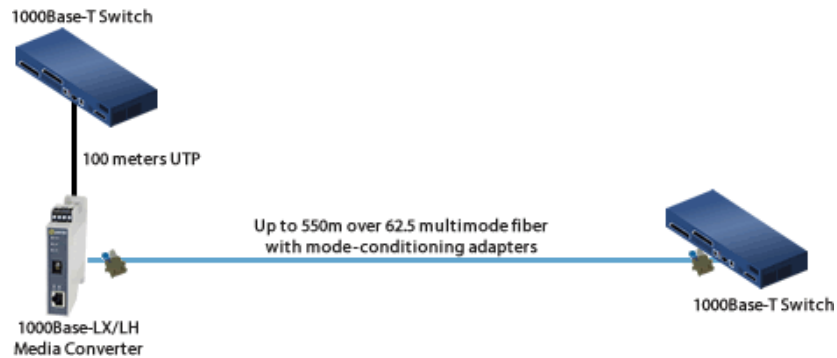

Gigabit to IP Cameras

Connect IP Cameras to Gigabit Backbone

Extend the reach to IP cameras using fiber media converters.

Stand-alone Media Converters are placed at the remote end connecting cameras with copper interfaces to fiber optic cabling. The fiber can extend the distance up to 160 kilometers using single mode or multimode fiber back to a control center. A media converter chassis located in the data closet at the control center accepts the fiber signal, converts it, and connects to the copper equipment at the main site.

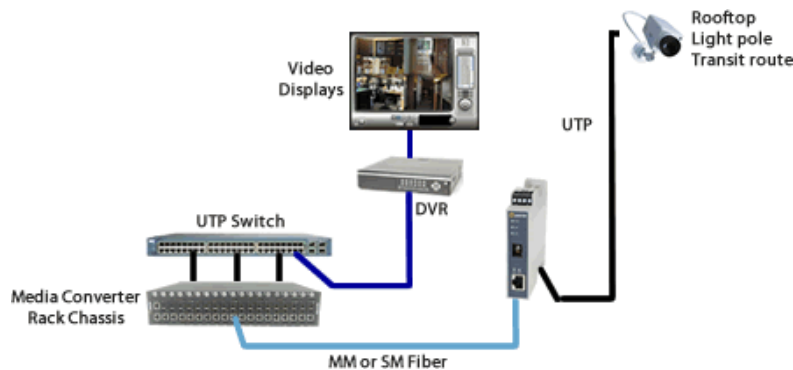

Gigabit Fiber to Wireless Access Points

Connect Wireless Access Points to Gigabit Backbone

Extend the reach to wireless access points (AP) using fiber media converters. When a company deploys a wireless network, APs need to be set up throughout the facility to ensure complete coverage for reliability. The network manager will likely need to extend further than the 100 meters allowed by copper cable to reach many of the APs.

Stand-alone Media Converters are placed at the remote end connecting APs with copper interfaces to fiber optic cabling. The fiber can extend the distance up to 160 kilometers using single mode or multimode fiber back to a control center. A media converter chassis located in the data closet at the control center accepts the fiber signal, converts it, and connects to the copper equipment at the main site.

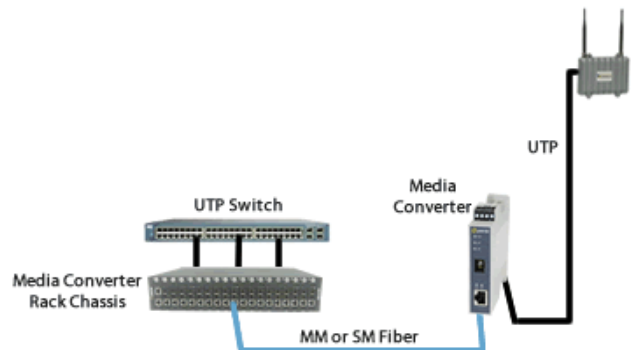

Enterprise Infrastructure

Enterprise Infrastructure using Fiber Optics

Create a fiber infrastructure for your enterprise network without any wholesale replacement of existing copper-based equipment.

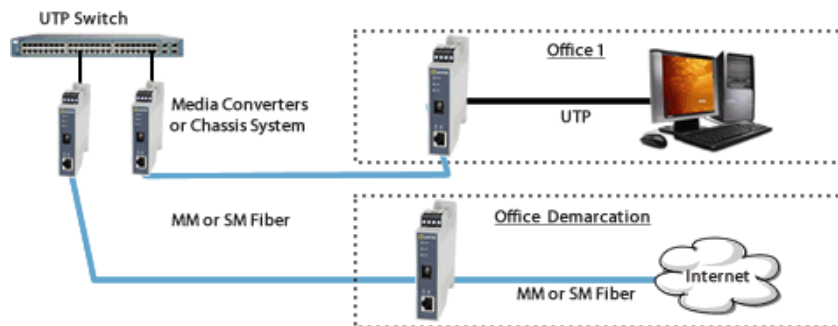

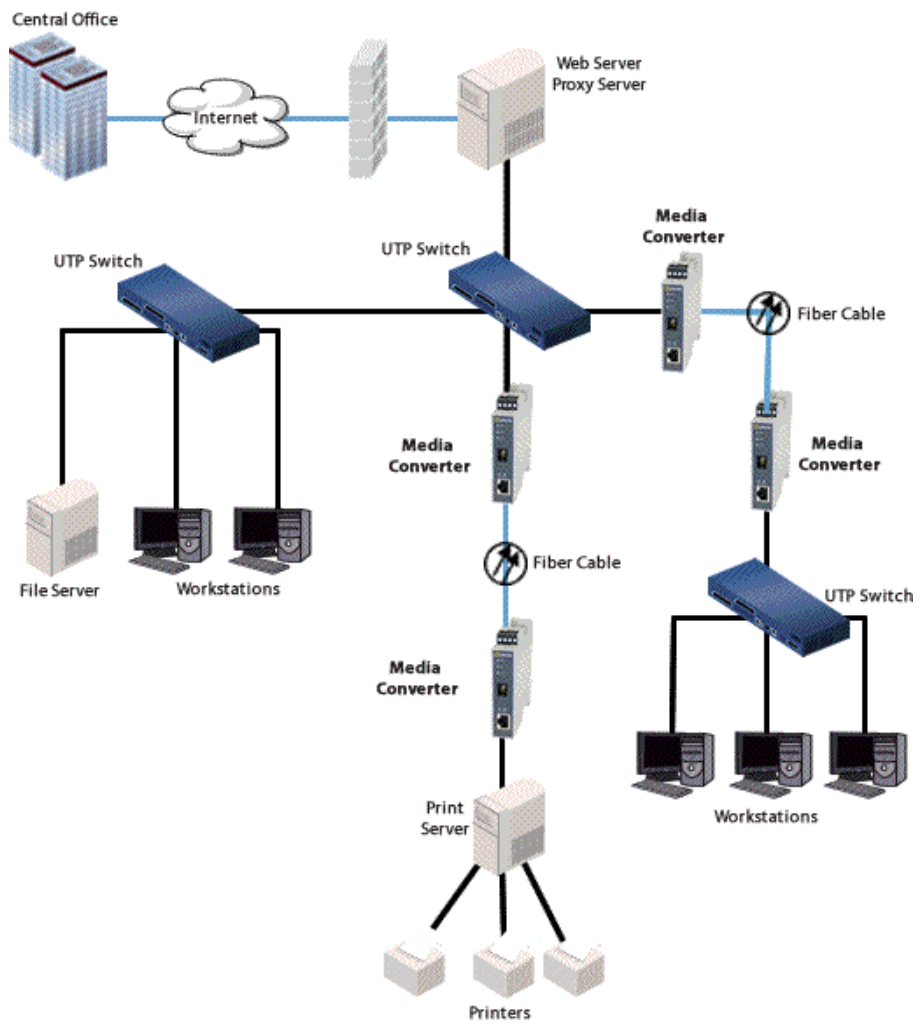

Single Mode / Single Fiber

Connect copper ports over a single fiber strand (also referred to as “Bi-Directional” BiDi)

When Single Strand fiber is used, a pair of Single Fiber Media Converters is needed for the copper to fiber conversion. Perle Single Fiber Media Converters are also referred to as “Up/Down” models. For example the SR-1000-SC05U (“Up”) and SR-1000-SC05D (“Down”), shown below, must be used in pairs. An “Up” must be matched with a “Down” peer to deal with transmit and receive frequencies separately.

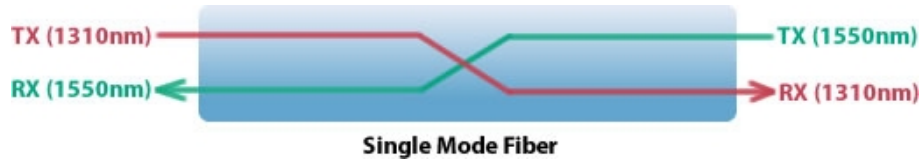

SR-1000-SC05U/SR-1000-SC05D

The majority of installations for single mode fiber media converters are of the “dual connector” or “dual fiber” type where one fiber connection is used for transmit, the other for receive. These are physically “crossed” to match up the Transmit/Receive links.

However, to reduce costs, or where there are limits on available fiber, WDM technology may be utilized. WDM uses separate transmit and receive frequencies to communicate on a single fiber strand. WDM technology relies on the fact that optical fibers can carry many wavelengths of light simultaneously without interaction between each wavelength. Thus, a single fiber can carry many separate wavelength signals or channels simultaneously.

So remember, if Single Strand fiber is used, you will need an “Up” Media Converter on one side and a “Down” Media Converter on the other for copper to fiber conversion.

Perle offers a wide variety of Single Fiber (“Up/Down”) Media Converters to connect 10BaseT, Fast Ethernet and Gigabit to single fiber. Whether you need Managed or Unmanaged, Standalone or Modular Chassis Based, 20km or 120km, Perle has the right model to meet your fiber conversion requirement.

Select a Model to obtain a Part Number - SR-1000 DIN Rail Media Converters

Dual Fiber Models

Model	Connector	Type	Transmit (dBm)		Receive (dBm)		Power Budget (dBm)	Wavelength (nm)	Fiber Type	Core Size (um)	Modal Bandwidth (MHz* Km)	Operating Distance
			Min	Max	Min	Max						
SR-1000-SC05	Dual SC	1000Base-SX	-9.5	-4.0	-17.0	-3.0	7.5	850	MMF	62.5	160	220 m (722 ft)
										62.5	200	275 m (902 ft)
										50	400	500 m (1,640 ft)
										50	500	550 m (1,804 ft)
										50	2000	1000 m (3281 ft)

SR-1000-ST05	Dual ST	1000Base-SX	-9.5	-4.0	-17.0	-3.0	7.5	850	MMF	62.5	160	220 m (722 ft)
										62.5	200	275 m (902 ft)
										50	400	500 m (1,640 ft)
										50	500	550 m (1,804 ft)
										50	2000	1000 m (3281 ft)
SR-1000-SC2	Dual SC	1000Base-LX	-6.0	0.0	-17.0	-0.0	11	1310	MMF	62.5	160	2 km (1.2 mi)
										50	500	1000m (3280 ft)
SR-1000-ST2	Dual ST	1000Base-LX	-6.0	0.0	-17.0	-0.0	11	1310	MMF	62.5	160	2 km (1.2 mi)
										50	500	1000m (3280 ft)
SR-1000-SC10	Dual SC	1000Base-LX/LH	-9.5	-3.0	-20.0	-3.0	10.5	1310	MMF*	62.5	500	550 m (1804 ft)
										50	400	550 m (1,804 ft)
										50	500	550 m (1,804 ft)
									SMF	**	-	10 km (6.2 mi)
SR-1000-ST10	Dual ST	1000Base-LX/LH	-9.5	-3.0	-20.0	-3.0	10.5	1310	MMF*	62.5	500	550 m (1804 ft)
										50	400	550 m (1,804 ft)
										50	500	550 m (1,804 ft)
									SMF	**	-	10 km (6.2 mi)
SR-1000-SC40	Dual SC	1000Base-EX	-2.0	2.0	-23.0	-3.0	21.0	1310	SMF	**	-	40 km (25 mi)

SR-1000-ST40	Dual ST	1000Base-EX	-2.0	2.0	-23.0	-3.0	21.0	1310	SMF	**	-	40 km (25 mi)
SR-1000-SC70	Dual SC	1000Base-ZX	-2.0	5.0	-23.0	-3.0	21.0	1550	SMF	-	-	70 km (43 mi)
SR-1000-ST70	Dual ST	1000Base-ZX	-2.0	5.0	-23.0	-3.0	21.0	1550	SMF	-	-	70 km (43 mi)
SR-1000-SC120	Dual SC	1000Base-ZX	0.0	5.0	-32.0	-9.0	32	1550	SMF	-	-	120 km (75 mi)
SR-1000-ST120	Dual ST	1000Base-ZX	0.0	5.0	-32.0	-9.0	32	1550	SMF	-	-	120 km (75 mi)
SR-1000-SC160	Dual SC	1000Base-ZX	2.0	5.0	-34.0	-9.0	36	1550	SMF	-	-	160 km (100 mi)
SR-1000-ST160	Dual ST	1000Base-ZX	2.0	5.0	-34.0	-9.0	36	1550	SMF	-	-	160 km (100 mi)

Single Fiber Models Recommended use in pairs

Model	Connector	Type	Transmit (dBm)		Receive (dBm)		Power Budget (dBm)	Wavelength (nm)	Fiber Type	Core Size (um)	Modal Bandwidth (MHz* Km)	Operating Distance
			Min	Max	Min	Max						
SR-1000-SC05U	Single SC	1000Base-BX-U	-10.0	-4.0	-17.0	-3.0	7.0	1310 / 1550	MMF	62.5	500	500 m (1,640 ft)
										50	500	500m 1,640 ft)
SR-1000-SC05D	Single SC	1000Base-BX-D	-10.0	-4.0	-17.0	-3.0	7.0	1550 / 1310	MMF	62.5	500	500 m (1,640 ft)
										50	500	500m 1,640 ft)
SR-1000-SC10U-	Single SC	1000Base-BX-U	-9.0	-3.0	-20.0	-3.0	11.0	1310 / 1490	SMF	**	-	10 km (6.2 mi)
SR-1000-SC10D	Single SC	1000Base-BX-D	-9.0	-3.0	-20.0	-3.0	11.0	1490 / 1310	SMF	**	-	10 km (6.2 mi)

SR-1000-SC20U	Single SC	1000Base-BX-U	-8.0	-3.0	-22.0	-3.0	14.0	1310 / 1490	SMF	**	-	20 km (12.4 mi)
SR-1000-SC20D	Single SC	1000Base-BX-D	-8.0	-3.0	-22.0	-3.0	14.0	1490 / 1310	SMF	**	-	20 km (12.4 mi)
SR-1000-SC40U	Single SC	1000Base-BX-U	-3.0	2.0	-23.0	-3.0	20.0	1310 / 1490	SMF	**	-	40 km (25 mi)
SR-1000-SC40D	Single SC	1000Base-BX-D	-3.0	2.0	-23.0	-3.0	20.0	1490 / 1310	SMF	**	-	40 km (25 mi)
SR-1000-SC80U	Single SC	1000Base-BX-U	-2.0	3.0	-26.0	-3.0	24.0	1510 / 1590	SMF	-	-	80 km (50 mi)
SR-1000-SC80D	Single SC	1000Base-BX-D	-2.0	3.0	-26.0	-3.0	24.0	1590 / 1510	SMF	-	-	80 km (50 mi)
SR-1000-SC120U	Single SC	1000Base-BX-U	-3.0	2.0	-34.0	-9.0	31	1510 / 1590	SMF	-	-	120 km (75 mi)
SR-1000-SC120D	Single SC	1000Base-BX-D	-3.0	2.0	-34.0	-9.0	31	1590 / 1510	SMF	-	-	120 km (75 mi)





*A mode-conditioning adapter as specified by the IEEE standard, is required regardless of the span length. Note how the mode conditioning adapter for 62.5-um fibers has a different specification from the mode-conditioning adapter for 50-um fibers.







**ITU-T G.652 SMF as specified by the IEEE 802.3z standard.







Part Number	Media Converter Accessories
29029928	UNO-PS/1AC/24DC/60W DIN-Rail Power Supply: 24 VDC, 60 Watt with universal 85 to 264 VAC, -25 to 70°C extended operating temperature.
29043768	UNO-P/1AC/24DC/150W Power Supply - DIN-Rail 24 VDC , 150 Watt power supply with universal 85 to 264 VAC, -25 to 70°C extended operating temperature
28664918	TRIO-PS/1AC/48DC/5 DIN-Rail Power Supply: 48 VDC, 240 Watt with universal 85 to 264 VAC, 30 to 56V DC output range adjustable, -25 to 70°C extended operating temperature.
28665018	TRIO-PS/1AC/48DC/10 Power Supply - DIN-Rail 48 VDC , 480 Watt power supply with universal 85 to 264 VAC, 30 to 56V DC output range adjustable, -25 to 70°C extended operating temperature







28669838 MINI-SYS-PS-100-240AC/24DC/1.5 Power Supply - For use with modular TBUS DIN rail connector system. 24VDC / 1.5 A, 36 Watts with universal 85 to 264 VAC, -25 °C to 70 °C extended operating temperature



22038528 ME225TBUS15/4P1SBK - TBUS DIN Rail Connector - Transmit power voltage and data across the bus. 4 parallel positions and 1 serial position. UL 8A / cUL 6A, 150 V. Width 22.5cm. Carton of 5. For use with SR and SRS DIN Rail Media Converters.

Product Image	Description	Power Cord	Product Number
	<p>SR-1000-SC05- Gigabit Industrial Media Converter: 1000BASE-T (RJ-45) [100 m/328 ft] to 1000BASE-SX 850nm multimode (SC) [550 m/1804 ft]. DIN Rail case, terminal block (Combicon) power connector for external power source</p>	None	05091300
	<p>SR-1000-ST05- Gigabit Industrial Media Converter: 1000BASE-T (RJ-45) [100 m/328 ft] to 1000BASE-SX 850nm multimode (ST) [550 m/1804 ft]. DIN Rail case, terminal block (Combicon) power connector for external power source</p>	None	05091310
	<p>SR-1000-SC2- Gigabit Industrial Media Converter: 1000BASE-T (RJ-45) [100 m/328 ft] to 1000BASE-LX 1310nm extended multimode (SC) [2km /6562 ft]. DIN Rail case, terminal block (Combicon) power connector for external power source</p>	None	05091320
	<p>SR-1000-ST2- Gigabit Industrial Media Converter: 1000BASE-T (RJ-45) [100 m/328 ft] to 1000BASE-LX 1310nm extended multimode (ST) [2km /6562 ft]. DIN Rail case, terminal block (Combicon) power connector for external power source</p>	None	05091330
	<p>SR-1000-SC10- Gigabit Industrial Media Converter: 1000BASE-T (RJ-45) [100 m/328 ft] to 1000BASE-LX/LH 1310 nm single mode (SC) [10 km/6.2 miles]. DIN Rail case, terminal block (Combicon) power connector for external power source</p>	None	05091340



Product Image	Description	Power Cord	Product Number
	SR-1000-ST10- Gigabit Industrial Media Converter: 1000BASE-T (RJ-45) [100 m/328 ft] to 1000BASE-LX/LH 1310 nm single mode (ST) [10 km/6.2 miles]. DIN Rail case, terminal block (Combicon) power connector for external power source	None	05091350
	SR-1000-SC40- Gigabit Industrial Media Converter: 1000BASE-T (RJ-45) [100 m/328 ft] to 1000BASE-EX 1310 nm single mode (SC) [40 km/24.9 miles]. DIN Rail case, terminal block (Combicon) power connector for external power source	None	05091360
	SR-1000-ST40- Gigabit Industrial Media Converter: 1000BASE-T (RJ-45) [100 m/328 ft] to 1000BASE-EX 1310 nm single mode (ST) [40 km/24.9 miles]. DIN Rail case, terminal block (Combicon) power connector for external power source	None	05091370
	SR-1000-SC70- Gigabit Industrial Media Converter: 1000BASE-T (RJ-45) [100 m/328 ft] to 1000BASE-ZX 1550 nm single mode (SC) [70 km/43.5 miles]. DIN Rail case, terminal block (Combicon) power connector for external power source	None	05091380
	SR-1000-ST70- Gigabit Industrial Media Converter: 1000BASE-T (RJ-45) [100 m/328 ft] to 1000BASE-ZX 1550 nm single mode (ST) [70 km/43.5 miles]. DIN Rail case, terminal block (Combicon) power connector for external power source	None	05091390
	SR-1000-SC120- Gigabit Industrial Media Converter: 1000BASE-T (RJ-45) [100 m/328 ft] to 1000BASE-ZX 1550 nm single mode (SC) [120 km/74.6 miles]. DIN Rail case, terminal block (Combicon) power connector for external power source	None	05091410



Product Image	Description	Power Cord	Product Number
	SR-1000-ST120- Gigabit Industrial Media Converter: 1000BASE-T (RJ-45) [100 m/328 ft] to 1000BASE-ZX 1550 nm single mode (ST) [120 km/74.6 miles]. DIN Rail case, terminal block (Combicon) power connector for external power source	None	05091400
	SR-1000-SC160- Gigabit Industrial Media Converter: 1000BASE-T (RJ-45) [100 m/328 ft] to 1000BASE-ZX 1550 nm single mode (SC) [160 km/100 miles]. DIN Rail case, terminal block (Combicon) power connector for external power source	None	05091420
	SR-1000-ST160- Gigabit Industrial Media Converter: 1000BASE-T (RJ-45) [100 m/328 ft] to 1000BASE-ZX 1550 nm single mode (ST) [160 km/100 miles]. DIN Rail case, terminal block (Combicon) power connector for external power source	None	05091430
	SR-1000-SC05U- Gigabit Industrial Media Converter: 1000BASE-T (RJ-45) [100 m/328 ft] to 1000BASE-BX 1310nm TX / 1550nm RX single strand fiber, multimode (SC) [500 m/1640 ft]. DIN Rail case, terminal block (Combicon) power connector for external power source	None	05091550
	SR-1000-SC05D- Gigabit Industrial Media Converter: 1000BASE-T (RJ-45) [100 m/328 ft] to 1000BASE-BX 1550nm TX / 1310nm RX single strand fiber, multimode (SC) [500 m/1640 ft]. DIN Rail case, terminal block (Combicon) power connector for external power source	None	05091540
	SR-1000-SC10U- Gigabit Industrial Media Converter: 1000BASE-T (RJ-45) [100 m/328 ft] to 1000BASE-BX 1310nm TX / 1490nm RX single strand fiber, single mode (SC) [10 km/6.2 miles]. DIN Rail case, terminal block (Combicon) power connector for external power source	None	05091440

Product Image	Description	Power Cord	Product Number
	SR-1000-SC10D- Gigabit Industrial Media Converter: 1000BASE-T (RJ-45) [100 m/328 ft] to 1000BASE-BX 1490nm TX / 1310nm RX single strand fiber, single mode (SC) [10 km/6.2 miles]. DIN Rail case, terminal block (Combicon) power connector for external power source	None	05091450
	SR-1000-SC20U- Gigabit Industrial Media Converter: 1000BASE-T (RJ-45) [100 m/328 ft] to 1000BASE-BX 1310nm TX / 1490nm RX single strand fiber, single mode (SC) [20 km/12.4 miles]. DIN Rail case, terminal block (Combicon) power connector for external power source	None	05091460
	SR-1000-SC20D- Gigabit Industrial Media Converter: 1000BASE-T (RJ-45) [100 m/328 ft] to 1000BASE-BX 1490nm TX / 1310nm RX single strand fiber, single mode (SC) [20 km/12.4 miles]. DIN Rail case, terminal block (Combicon) power connector for external power source	None	05091470
	SR-1000-SC40U- Gigabit Industrial Media Converter: 1000BASE-T (RJ-45) [100 m/328 ft] to 1000BASE-BX 1310nm TX / 1490nm RX single strand fiber, single mode (SC) [40 km/25 miles]. DIN Rail case, terminal block (Combicon) power connector for external power source	None	05091480
	SR-1000-SC40D- Gigabit Industrial Media Converter: 1000BASE-T (RJ-45) [100 m/328 ft] to 1000BASE-BX 1490nm TX / 1310nm RX single strand fiber, single mode (SC) [40 km/25 miles]. DIN Rail case, terminal block (Combicon) power connector for external power source	None	05091490
	SR-1000-SC80U- Gigabit Industrial Media Converter: 1000BASE-T (RJ-45) [100 m/328 ft] to 1000BASE-BX 1510nm TX / 1590nm RX single strand fiber, single mode (SC) [80 km/50 miles]. DIN Rail case, terminal block (Combicon) power connector for external power source	None	05091500

Product Image	Description	Power Cord	Product Number
	SR-1000-SC80D - Gigabit Industrial Media Converter: 1000BASE-T (RJ-45) [100 m/328 ft] to 1000BASE-BX 1590nm TX / 1510nm RX single strand fiber, single mode (SC) [80 km/50 miles]. DIN Rail case, terminal block (Combicon) power connector for external power source	None	05091510
	SR-1000-SC120U - Gigabit Industrial Media Converter: 1000BASE-T (RJ-45) [100 m/328 ft] to 1000BASE-BX 1510nm TX / 1590nm RX single strand fiber, single mode (SC) [120 km/75 miles]. DIN Rail case, terminal block (Combicon) power connector for external power source	None	05091520
	SR-1000-SC120D - Gigabit Industrial Media Converter: 1000BASE-T (RJ-45) [100 m/328 ft] to 1000BASE-BX 1590nm TX / 1510nm RX single strand fiber, single mode (SC) [120 km/75 miles]. DIN Rail case, terminal block (Combicon) power connector for external power source	None	05091530

Accessories

Accessory Image	Description	Model Number	Accessory Number
Power Supply			
	TRIO-PS/1AC/48DC/5 DIN-Rail Power Supply: 48 VDC, 240 Watt with universal 85 to 264 VAC, 30 to 56V DC output range adjustable, -25 to 70°C extended operating temperature.	TRIO-PS/1AC/48DC/5 Power Supply	28664918
	TRIO-PS/1AC/48DC/10 Power Supply - DIN-Rail 48 VDC , 480 Watt power supply with universal 85 to 264 VAC, 30 to 56V DC output range adjustable, -25 to 70°C extended operating temperature	TRIO-PS/1AC/48DC/10 Power Supply	28665018

Accessory Image	Description	Model Number	Accessory Number
	<p>MINI-SYS-PS-100-240AC/24DC/1.5 Power Supply - For use with modular TBUS DIN rail connector system. 24VDC / 1.5 A, 36 Watts with universal 85 to 264 VAC, -25 °C to 70 °C extended operating temperature</p>	<p>MINI-SYS-PS-100-240AC/24DC/1.5 Power Supply</p>	<p>28669838</p>
	<p>UNO-PS/1AC/24DC/60W DIN-Rail Power Supply: 24 VDC, 60 Watt with universal 85 to 264 VAC, -25 to 70°C extended operating temperature.</p>	<p>UNO-PS/1AC/24DC/60W Power Supply</p>	<p>29029928</p>
	<p>UNO-PS/1AC/24DC/150W Power Supply - DIN-Rail 24 VDC , 150 Watt power supply with universal 85 to 264 VAC, -25 to 70°C extended operating temperature</p>	<p>UNO-PS/1AC/24DC/150W Power Supply</p>	<p>29043768</p>