

10	9	8	7	6	5	4	3
SINGLE ASSEMBLY PART NO.	KIT ASSEMBLY PART NO.	WIRE AWG	GROMMET	COLOR	O-RING	COLOR	CABLE SEALING RANGE
1301990045	1301990145	2/0	HNBR	BLACK	HNBR	BLACK	15.88/.625 - 17.45/.687
1301990035	1301990135	3/0	HNBR	BLACK	HNBR	BLACK	17.45/.684 - 19.05/.750
1301990040	1301990140	4/0	HNBR	BLACK	HNBR	BLACK	19.05/.750 - 22.23/.875
1301990245	1301990345	2/0	SILICONE	RUST RED	SILICONE	RUST RED	15.88/.625 - 17.45/.687
1301990235	1301990335	3/0	SILICONE	RUST RED	SILICONE	RUST RED	17.45/.684 - 19.05/.750
1301990240	1301990340	4/0	SILICONE	RUST RED	SILICONE	RUST RED	19.05/.750 - 22.23/.875

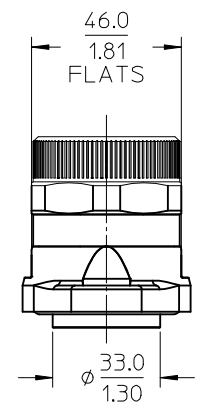
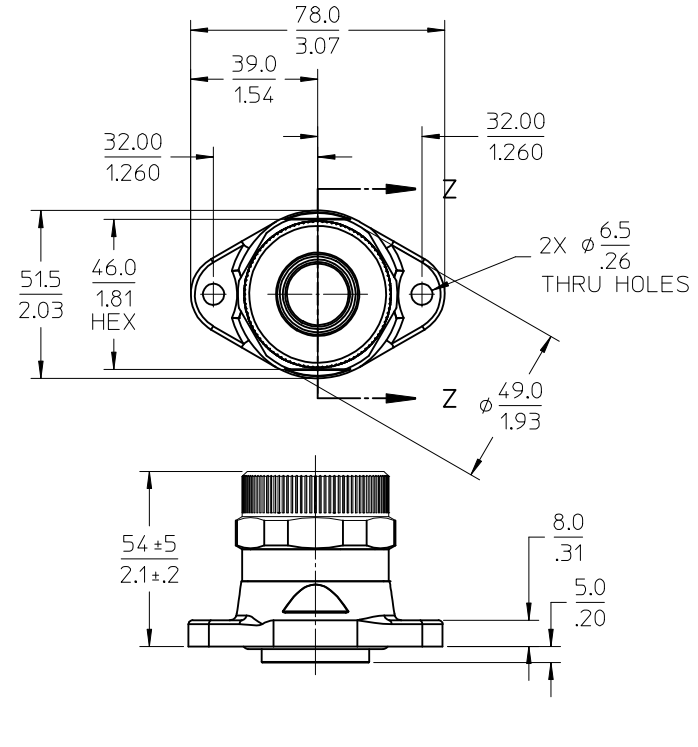
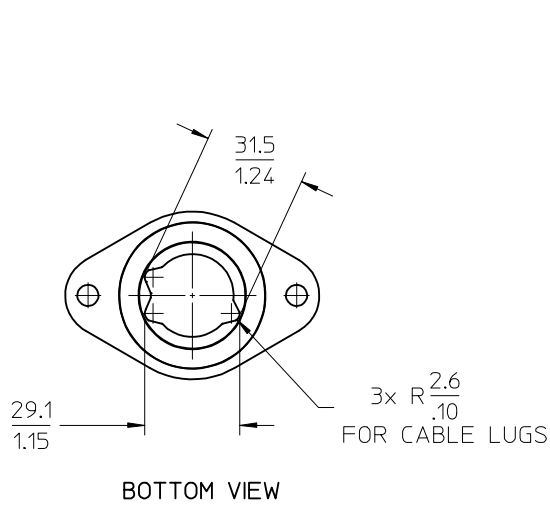

- NOTES:**
- MATERIALS:**
 GRIP BODY: ALUMINUM ALLOY
 FINISH: ELECTROLESS NICKEL PLATING
 COMPRESSION NUT: ALUMINUM ALLOY
 FINISH: ELECTROLESS NICKEL PLATING
 SHIELD RING: ALUMINUM ALLOY
 FINISH: ELECTROLESS NICKEL PLATING
 STOP RING: ALUMINUM ALLOY
 FINISH: ELECTROLESS NICKEL PLATING
 GROMMET: SEE CHART
 HNBR HARDNESS: SHORE 70A DUROMETER
 SILICONE HARDNESS: SHORE 70A DUROMETER
 O-RING: SEE CHART
 HNBR HARDNESS: SHORE 90A DUROMETER
 SILICONE HARDNESS: SHORE 70A DUROMETER
 - PRODUCT SPECIFICATION: PS-130199-001
 - PACKAGING SPECIFICATION: PK-130199-002
 - ASSEMBLY SPECIFICATION: AS-130199-003
 - ALL MATERIALS ARE ROHS COMPLIANT.

UPDATE TOLS & NOTES EC NO: IPG2016-0642 DRW: WLEUNG 2015/10/28 CHK: GSUDHINI 2015/10/28 APPR: BWOODMAN 2016/01/21	DESCRIPTION REV	QUALITY SYMBOLS ▽=0 ▽=0	GENERAL TOLERANCES (UNLESS SPECIFIED) <table border="1"> <thead> <tr> <th></th> <th>mm</th> <th>INCH</th> </tr> </thead> <tbody> <tr> <td>4 PLACES</td> <td>± ---</td> <td>± ---</td> </tr> <tr> <td>3 PLACES</td> <td>± ---</td> <td>± .015</td> </tr> <tr> <td>2 PLACES</td> <td>± 0.40</td> <td>± .03</td> </tr> <tr> <td>1 PLACE</td> <td>± 0.8</td> <td>± ---</td> </tr> </tbody> </table> ANGULAR ± 3°		mm	INCH	4 PLACES	± ---	± ---	3 PLACES	± ---	± .015	2 PLACES	± 0.40	± .03	1 PLACE	± 0.8	± ---	DIMENSION STYLE MM/IN	SCALE 1:1.5	DESIGN UNITS METRIC	THIRD ANGLE PROJECTION
			mm	INCH																		
		4 PLACES	± ---	± ---																		
		3 PLACES	± ---	± .015																		
2 PLACES	± 0.40	± .03																				
1 PLACE	± 0.8	± ---																				
DRAFT WHERE APPLICABLE MUST REMAIN WITHIN DIMENSIONS			DRAWN BY WLEUNG	DATE 2012/04/09	TITLE MAXLOC SHIELDED CORD GRIP ASSEMBLY, M40 THD FOR 2/0AWG TO 4/0AWG																	
			CHECKED BY BRUPERT	DATE 2013/11/21	MOLEX INCORPORATED																	
			APPROVED BY BWOODMAN	DATE 2013/12/26	DOCUMENT NO. SD-130199-002	SHEET NO. 1 OF 2																

ITEM NO.	DESCRIPTION
1	GRIP BODY, M40 THREAD
2	O-RING, HNBR
	O-RING, SI
3	SHIELD RING (2/0 AWG), 14.55/.573" ID
	SHIELD RING (3/0 AWG), 15.62/.615" ID
	SHIELD RING (4/0 AWG), 18.85/.742" ID
4	COMPRESSION NUT (2/0AWG), 20.00/.787" ID
	COMPRESSION NUT (3/0AWG), 20.57/.810" ID
	COMPRESSION NUT (4/0AWG), 24.77/.975" ID
5	GROMMET (2/0 AWG), 17.45/.687" ID
	GROMMET (3/0 AWG), 18.04/.710" ID
	GROMMET (4/0 AWG), 22.23/.875" ID
6	STOP RING, 9.80MM THICK
	STOP RING, 11.30MM THICK

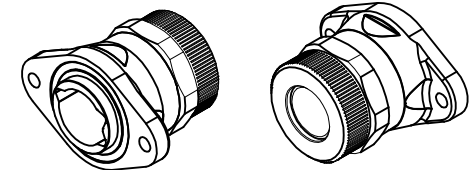

ISOMETRIC VIEWS
SCALE 1:2

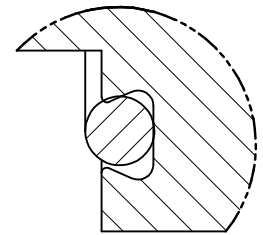
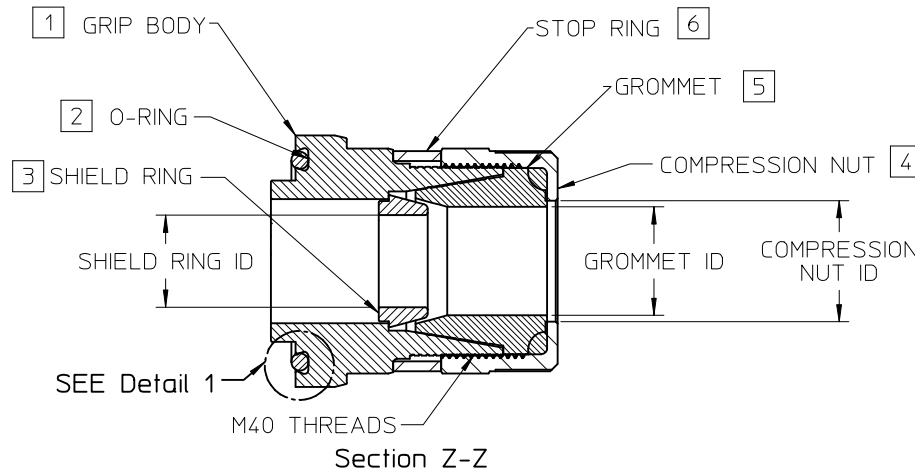

Detail 1
Scale 4:1

DUAL DOVETAIL
O-RING GROOVE

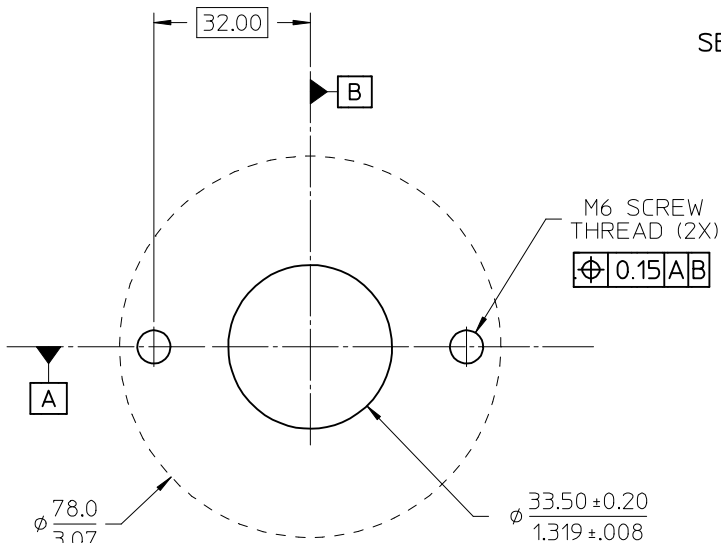

SEAL SURFACE ZONE
WITHIN Ø78.0 AREA:
SURFACE FINISH REQUIRED ∇ 3.2/
FLATNESS REQUIRED \square 0.2

RECOMMENDED PANEL
MOUNT OPENING

UPDATE ID DIMS & O-RING GROOVE EC NO: IPG2016-0642 IT DRW:WLEUNG 2015/10/28 CHKD:GSUDHINI 2015/10/28 APPR:BWODMAN 2016/01/21 REV DESCRIPTION	QUALITY SYMBOLS	GENERAL TOLERANCES (UNLESS SPECIFIED)	DIMENSION STYLE	SCALE	DESIGN UNITS	THIRD ANGLE PROJECTION
	$\nabla=0$	mm INCH	MM/IN	1:1	METRIC	
	$\nabla=0$	4 PLACES ± --- ± ---	DRAWN BY DATE			
		3 PLACES ± --- ± .015	WLEUNG 2012/04/09			
	2 PLACES ± 0.40 ± .03	CHECKED BY DATE				MAXLOC SHIELDED CORD GRIP ASSEMBLY, M40 THD FOR 2/0AWG TO 4/0AWG
	1 PLACE ± 0.8 ± ---	BRUPERT 2013/11/21				
	ANGULAR ± 3°	APPROVED BY DATE				MOLEX INCORPORATED
		BWOODMAN 2013/12/26				
	DRAFT WHERE APPLICABLE MUST REMAIN WITHIN DIMENSIONS	MATERIAL NO.	SEE CHART	DOCUMENT NO.		SHEET NO.
		SIZE B		SD-130199-002		2 OF 2
		THIS DRAWING CONTAINS INFORMATION THAT IS PROPRIETARY TO MOLEX INCORPORATED AND SHOULD NOT BE USED WITHOUT WRITTEN PERMISSION				

10	9	8	7	6	5	4	3
SINGLE ASSEMBLY PART NO.	KIT ASSEMBLY PART NO.	WIRE AWG	GROMMET	COLOR	O-RING	COLOR	CABLE SEALING RANGE
1301990045	1301990145	2/0	HNBR	BLACK	HNBR	BLACK	15.88/.625 - 17.45/.687
1301990035	1301990135	3/0	HNBR	BLACK	HNBR	BLACK	17.45/.684 - 19.05/.750
1301990040	1301990140	4/0	HNBR	BLACK	HNBR	BLACK	19.05/.750 - 22.23/.875
1301990245	1301990345	2/0	SILICONE	RUST RED	SILICONE	RUST RED	15.88/.625 - 17.45/.687
1301990235	1301990335	3/0	SILICONE	RUST RED	SILICONE	RUST RED	17.45/.684 - 19.05/.750
1301990240	1301990340	4/0	SILICONE	RUST RED	SILICONE	RUST RED	19.05/.750 - 22.23/.875

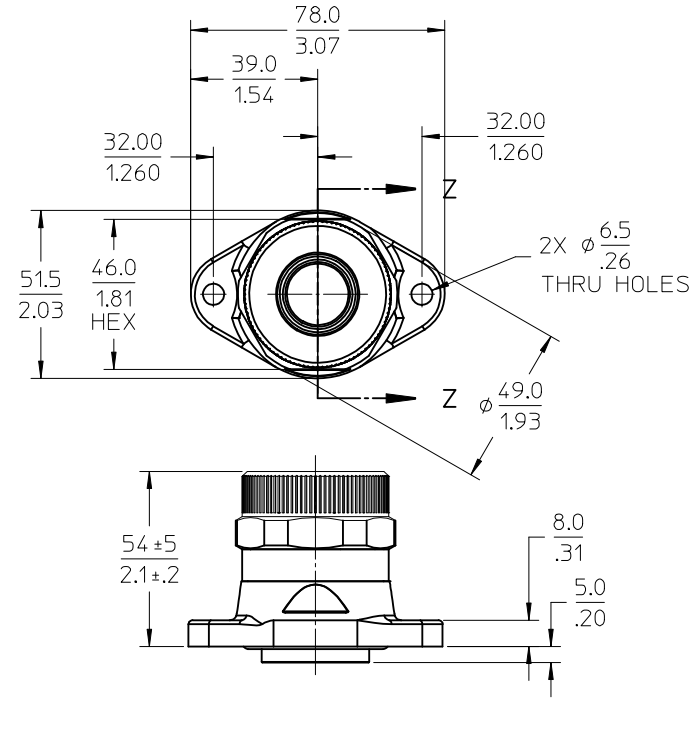
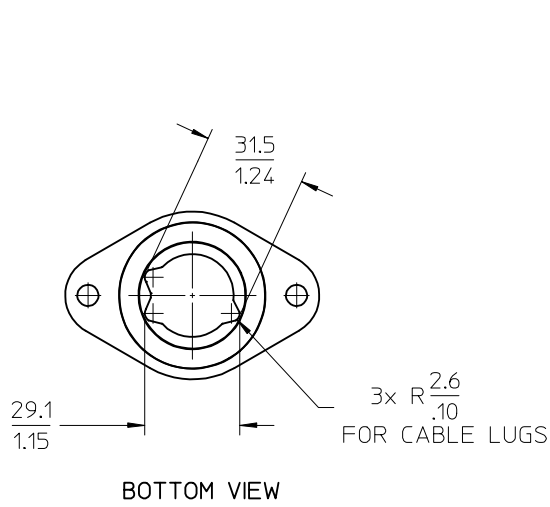

- NOTES:
- MATERIALS:
GRIP BODY: ALUMINUM ALLOY
FINISH: ELECTROLESS NICKEL PLATING
COMPRESSION NUT: ALUMINUM ALLOY
FINISH: ELECTROLESS NICKEL PLATING
SHIELD RING: ALUMINUM ALLOY
FINISH: ELECTROLESS NICKEL PLATING
STOP RING: ALUMINUM ALLOY
FINISH: ELECTROLESS NICKEL PLATING
GROMMET: SEE CHART
HNBR HARDNESS: SHORE 70A DUROMETER
SILICONE HARDNESS: SHORE 70A DUROMETER
O-RING: SEE CHART
HNBR HARDNESS: SHORE 90A DUROMETER
SILICONE HARDNESS: SHORE 70A DUROMETER
 - PRODUCT SPECIFICATION: PS-130199-001
 - PACKAGING SPECIFICATION: PK-130199-002
 - ASSEMBLY SPECIFICATION: AS-130199-003
 - ALL MATERIALS ARE ROHS COMPLIANT.

UPDATE TOLS & NOTES EC NO: IPG2016-0642 DRW:WLEUNG 2015/10/28 CHKD:GSUDHINI 2015/10/28 APPR:BWODMAN 2016/01/21	QUALITY SYMBOLS ▽=0 ▽=0	GENERAL TOLERANCES (UNLESS SPECIFIED)		DIMENSION STYLE MM/IN		SCALE 1:1.5	DESIGN UNITS METRIC	THIRD ANGLE PROJECTION			
		4 PLACES ± --- ± ---	3 PLACES ± --- ± .015	2 PLACES ± 0.40 ± .03	1 PLACE ± 0.8 ± ---	ANGULAR ± 3°	DRAWN BY WLEUNG	DATE 2012/04/09	TITLE MAXLOC SHIELDED CORD GRIP ASSEMBLY, M40 THD FOR 2/0AWG TO 4/0AWG		
		DRAFT WHERE APPLICABLE MUST REMAIN WITHIN DIMENSIONS		SEE CHART		APPROVED BY BWODMAN	DATE 2013/12/26	MOLEX INCORPORATED			
		MATERIAL NO.		DOCUMENT NO. SD-130199-002		SHEET NO. 1 OF 2					

ITEM NO.	DESCRIPTION
1	GRIP BODY, M40 THREAD
2	O-RING, HNBR
	O-RING, SI
3	SHIELD RING (2/0 AWG), 14.55/.573" ID
	SHIELD RING (3/0 AWG), 15.62/.615" ID
	SHIELD RING (4/0 AWG), 18.85/.742" ID
4	COMPRESSION NUT (2/0AWG), 20.00/.787" ID
	COMPRESSION NUT (3/0AWG), 20.57/.810" ID
	COMPRESSION NUT (4/0AWG), 24.77/.975" ID
5	GROMMET (2/0 AWG), 17.45/.687" ID
	GROMMET (3/0 AWG), 18.04/.710" ID
	GROMMET (4/0 AWG), 22.23/.875" ID
6	STOP RING, 9.80MM THICK
	STOP RING, 11.30MM THICK

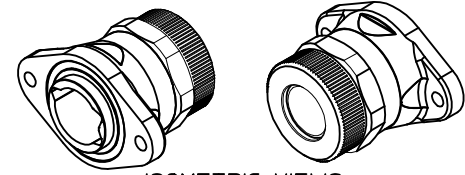

ISOMETRIC VIEWS
SCALE 1:2

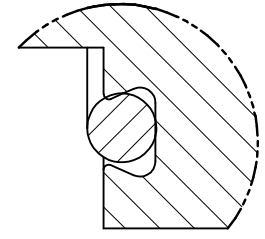
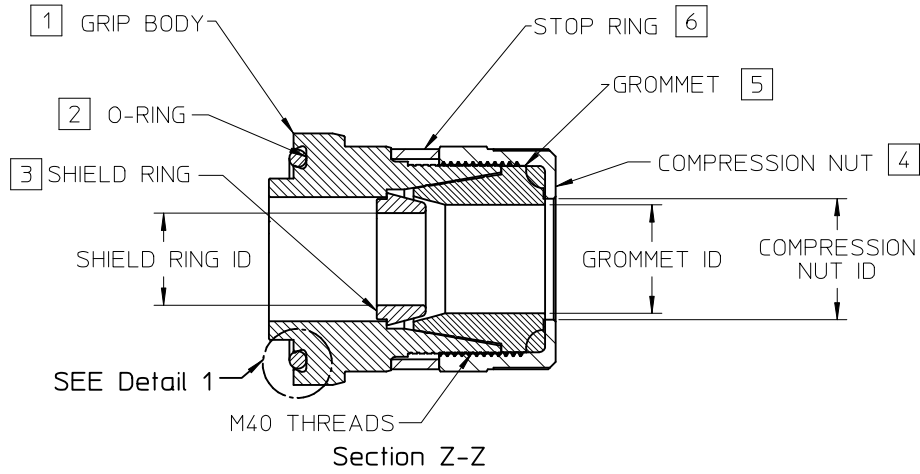

Detail 1
Scale 4:1
DUAL DOVETAIL
O-RING GROOVE

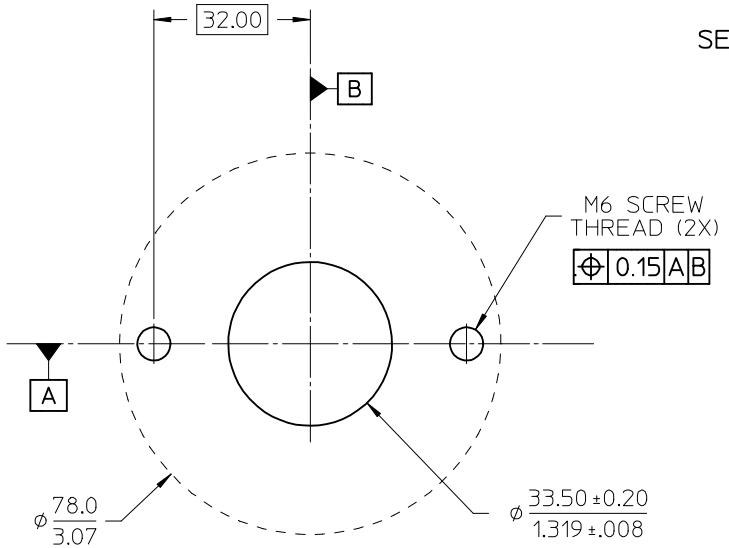

SEAL SURFACE ZONE
WITHIN Ø78.0 AREA:
SURFACE FINISH REQUIRED ∇ 3.2/
FLATNESS REQUIRED \square 0.2

RECOMMENDED PANEL
MOUNT OPENING

UPDATE ID DIMS & O-RING GROOVE EC NO: IPG2016-0642 IT DRW:WLEUNG 2015/10/28 CHKD:GSUDHINI 2015/10/28 APPR:BWODMAN 2016/01/21	QUALITY SYMBOLS $\blacktriangledown=0$ $\nabla=0$	GENERAL TOLERANCES (UNLESS SPECIFIED) <table border="1"> <thead> <tr> <th></th> <th>mm</th> <th>INCH</th> </tr> </thead> <tbody> <tr> <td>4 PLACES</td> <td>± ---</td> <td>± ---</td> </tr> <tr> <td>3 PLACES</td> <td>± ---</td> <td>± .015</td> </tr> <tr> <td>2 PLACES</td> <td>± 0.40</td> <td>± .03</td> </tr> <tr> <td>1 PLACE</td> <td>± 0.8</td> <td>± ---</td> </tr> </tbody> </table>		mm	INCH	4 PLACES	± ---	± ---	3 PLACES	± ---	± .015	2 PLACES	± 0.40	± .03	1 PLACE	± 0.8	± ---	DIMENSION STYLE MM/IN	SCALE 1:1	DESIGN UNITS METRIC	THIRD ANGLE PROJECTION
		mm	INCH																		
	4 PLACES	± ---	± ---																		
	3 PLACES	± ---	± .015																		
2 PLACES	± 0.40	± .03																			
1 PLACE	± 0.8	± ---																			
DRAWN BY WLEUNG	DATE 2012/04/09	TITLE MAXLOC SHIELDED CORD GRIP ASSEMBLY, M40 THD FOR 2/0AWG TO 4/0AWG																			
CHECKED BY BRUPERT	DATE 2013/11/21	MOLEX INCORPORATED																			
APPROVED BY BWODMAN	DATE 2013/12/26	MATERIAL NO. SEE CHART	DOCUMENT NO. SD-130199-002	SHEET NO. 2 OF 2	THIS DRAWING CONTAINS INFORMATION THAT IS PROPRIETARY TO MOLEX INCORPORATED AND SHOULD NOT BE USED WITHOUT WRITTEN PERMISSION																