

NOTES:

1. MATERIAL:
RECEPTACLE HOUSING: PBT POLYESTER. COLOR: BLACK, UL94-V0
2. PACKAGING SPECIFICATION : 2155116121-PK
3. PRODUCT SPECIFICATION: 2155100008-PS
4. APPLICATION SPECIFICATION: 2155101000-AS
5. TEST SUMMARY : 2155108000-TS
6. ASSEMBLY MEETS ROHS REQUIREMENT.
7. MATES WITH MOLEX R/A HEADER ASSEMBLY 215510-8031(SCREW MOUNT) AND 215510-8241(SOLDER VERSION).
8. SHEET 2 & 3 ILLUSTRATE ASSEMBLY VIEWS AND IT IS FOR VISUAL PURPOSE ONLY

THIS DRAWING CONTAINS INFORMATION THAT IS PROPRIETARY TO MOLEX ELECTRONIC TECHNOLOGIES, LLC AND SHOULD NOT BE USED WITHOUT WRITTEN PERMISSION									
DIMENSION UNITS	SCALE	CURRENT REV DESC: NEW VIEW ADDED TO ILLUSTRATE THE USAGE OF SHOULDER SCREW IN PLACE OF SELF CLINCHING STANDOFF FOR PANEL MOUNTING IN SHEET 4							
mm	4:1								
GENERAL TOLERANCES (UNLESS SPECIFIED)		EC NO: 745616			2CKT 8MM PANEL MOUNT RECEPTACLE HOUSING POWERWIZE PRODUCT FAMILY				
ANGULAR TOL	± 0.5°	DRWN: CHETAB 2023/03/10			PRODUCT CUSTOMER DRAWING				
4 PLACES	±	CHK'D: GSHARMA 2023/04/28			DOCUMENT NUMBER				
3 PLACES	±	APPR: HTHYAGARAJ 2023/05/05			2155118121				
2 PLACES	± 0.15	INITIAL REVISION:			DOC TYPE				
1 PLACE	± 0.25	DRWN: CHETAB 2021/05/17			PSD				
0 PLACES	±	APPR: HTHYAGARAJ 2021/11/05			000				
DRAFT WHERE APPLICABLE MUST REMAIN WITHIN DIMENSIONS		THIRD ANGLE PROJECTION	DRAWING	SERIES	MATERIAL NUMBER		CUSTOMER		SHEET NUMBER
			D-SIZE	215511	2155118121		GENERAL MARKET		1 OF 4

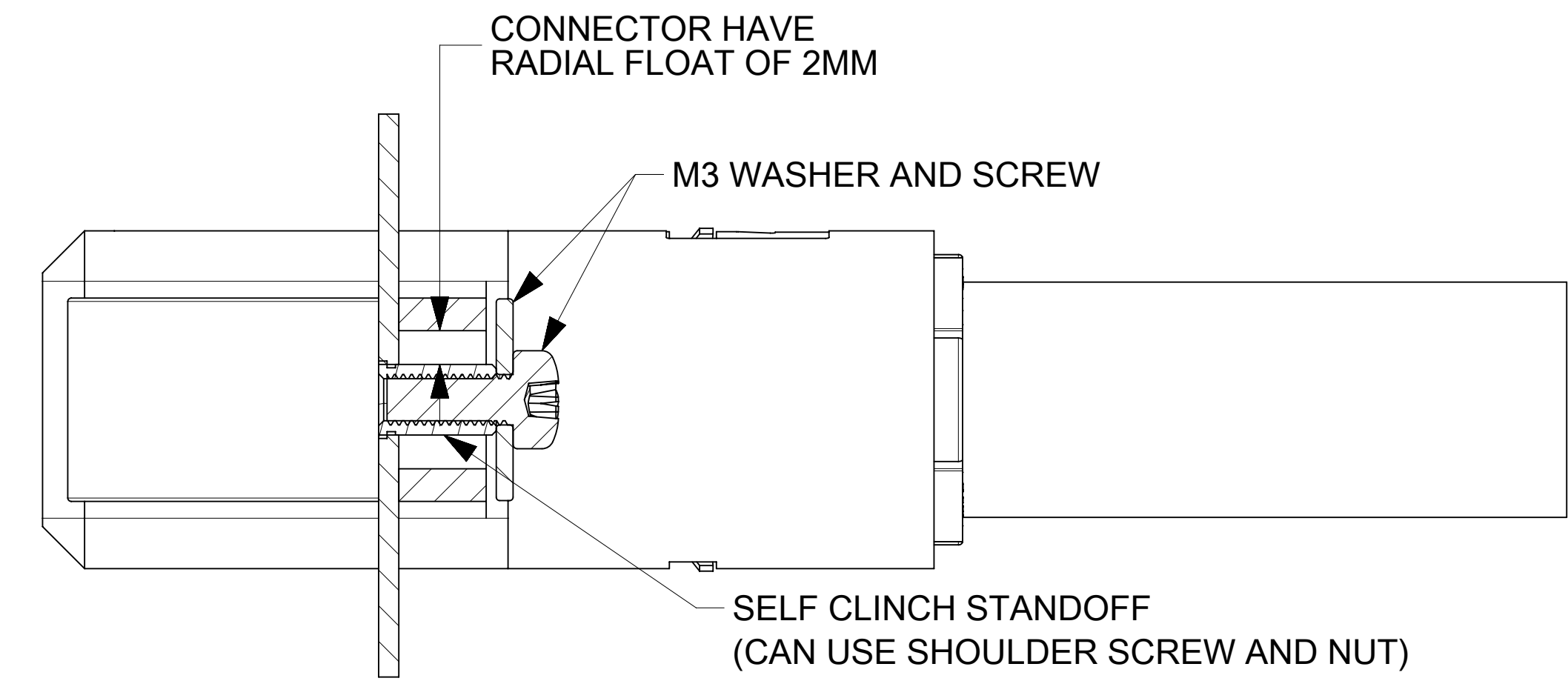
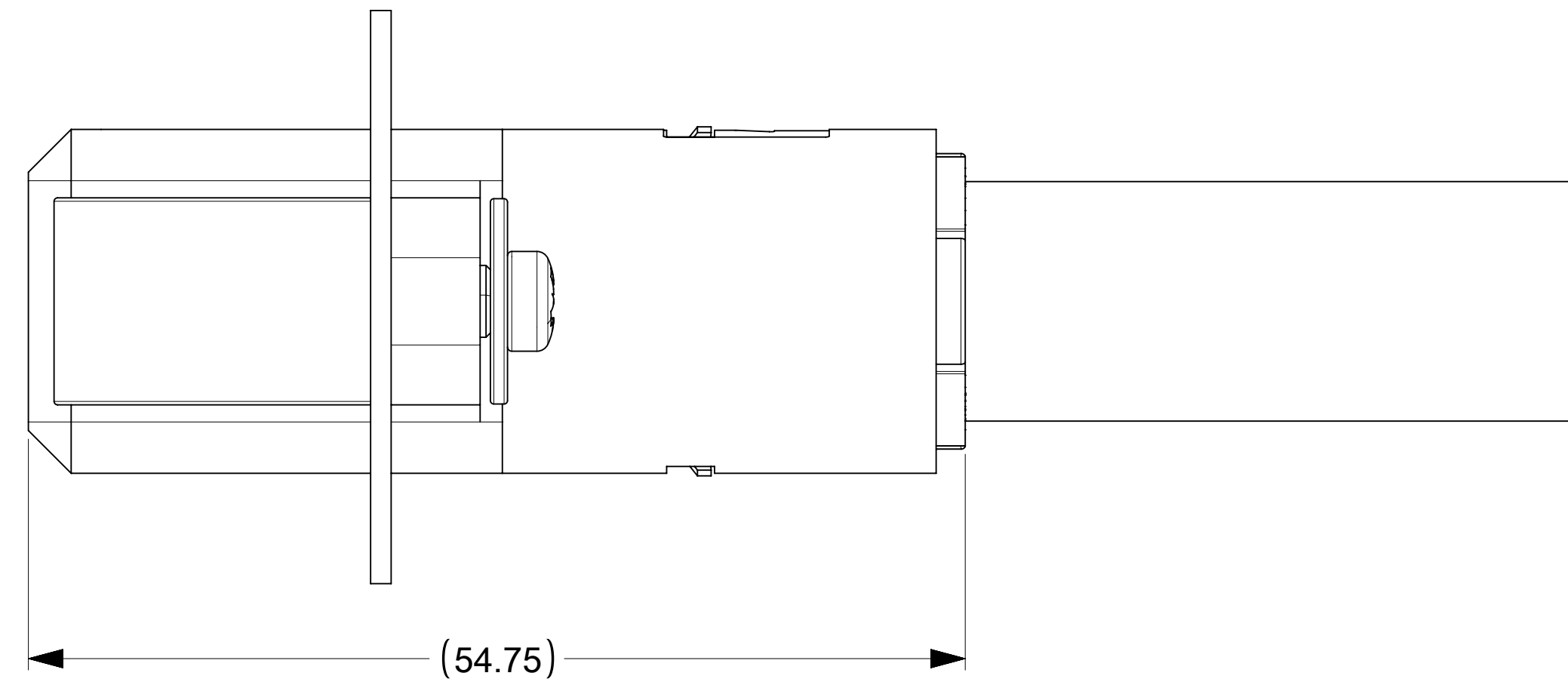
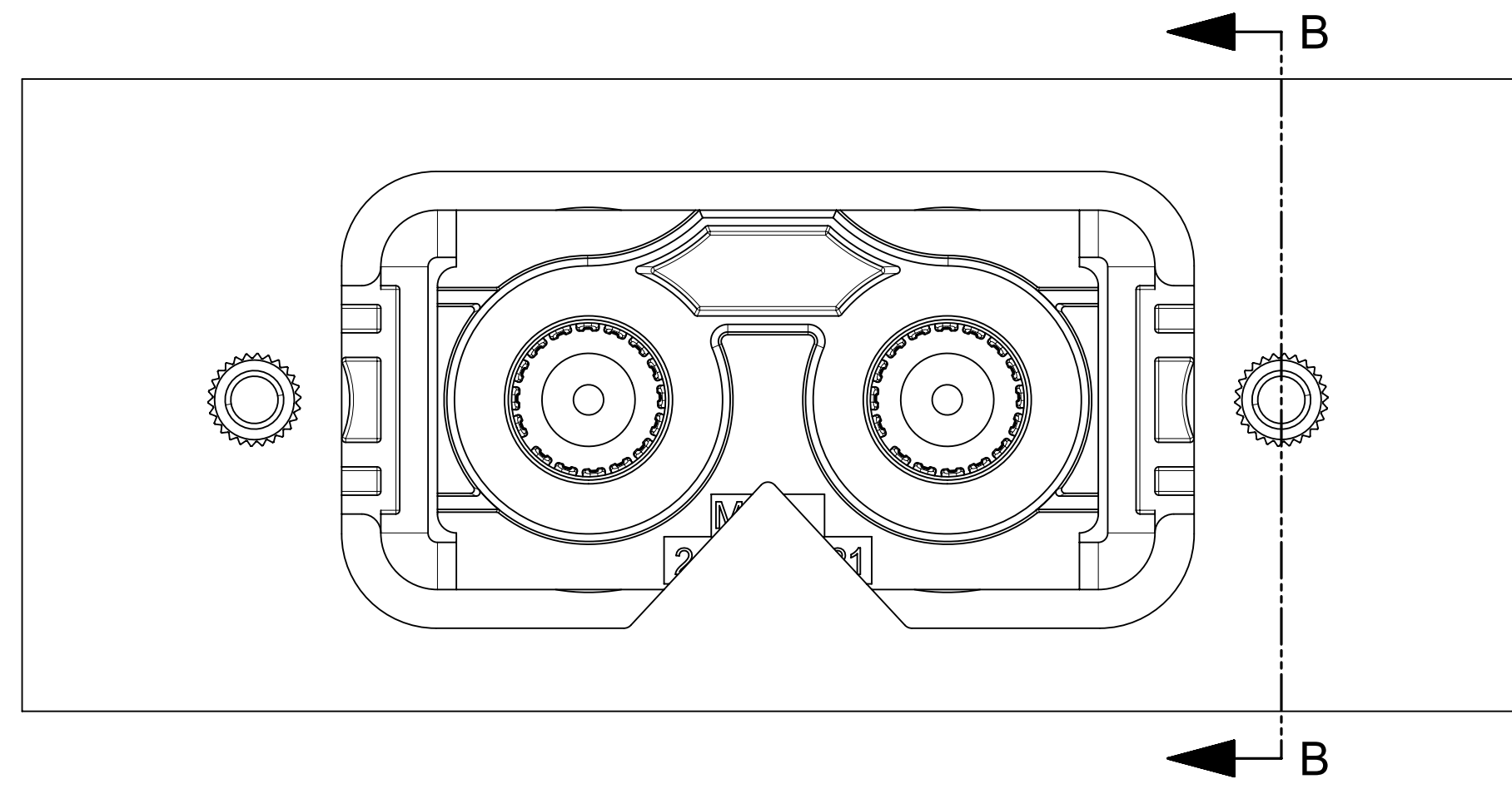

SECTION B-B

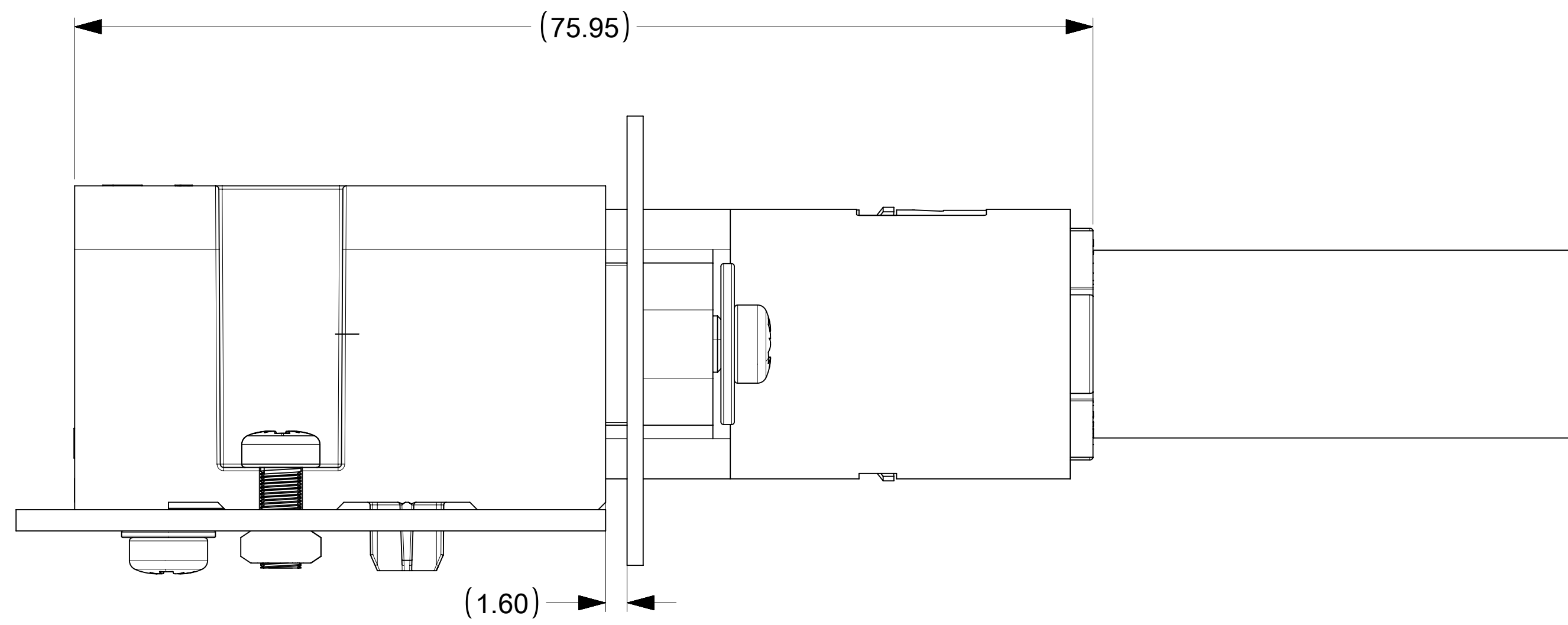

ASSEMBLED AND MATED WITH
RA HEADER_SCREW MOUNT VERSION (2155108031)

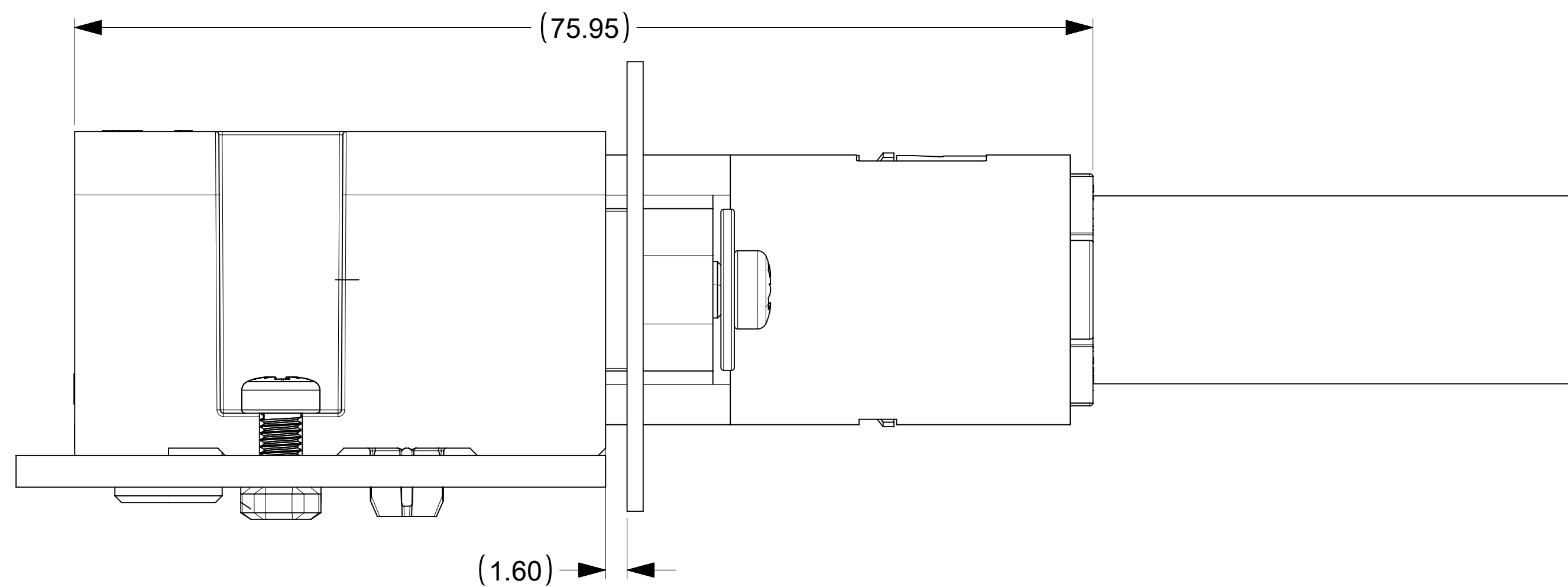

ASSEMBLED AND MATED WITH
RA HEADER_SOLDER TAIL VERSION (2155108241)

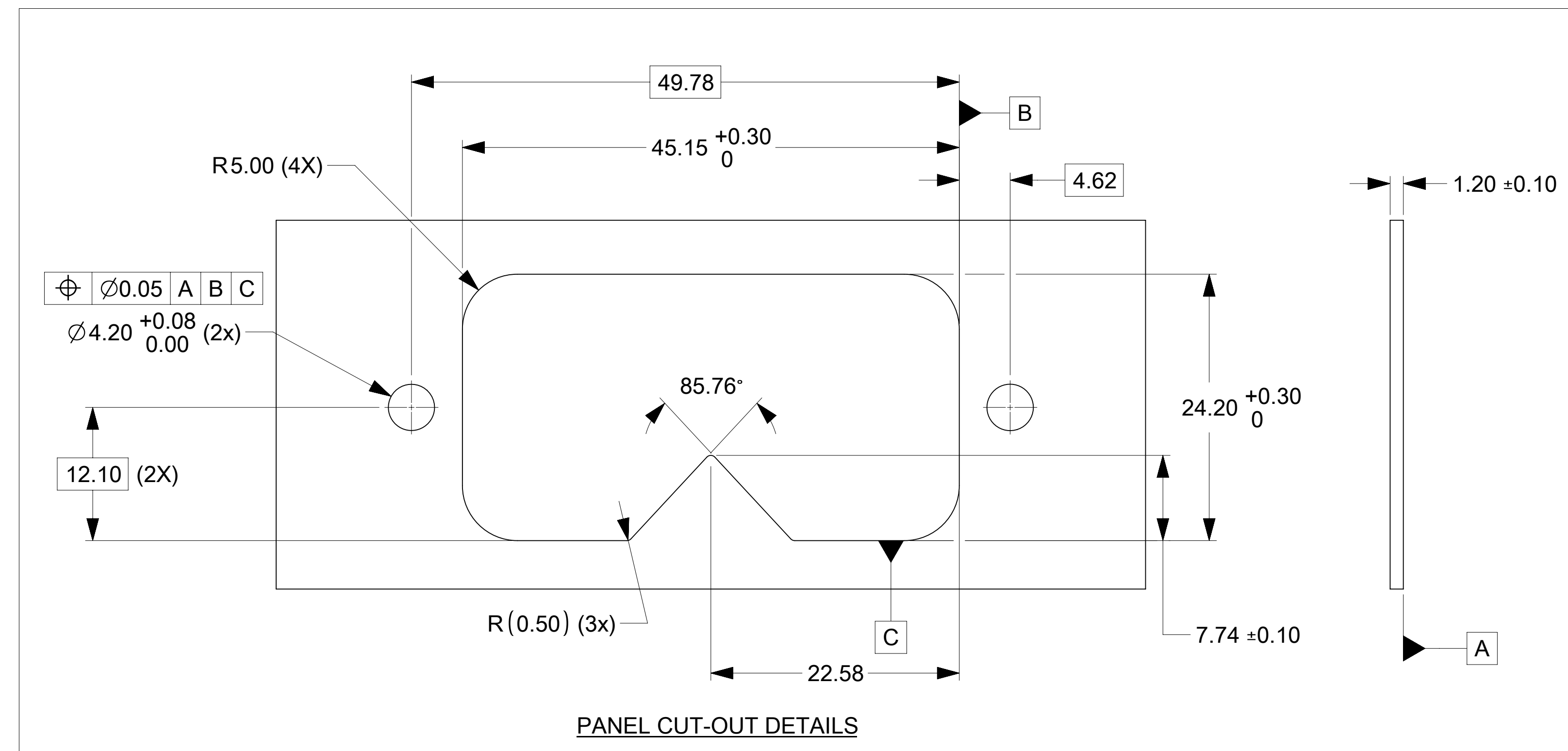

PANEL CUT-OUT DETAILS

THIS DRAWING CONTAINS INFORMATION THAT IS PROPRIETARY TO MOLEX ELECTRONIC TECHNOLOGIES, LLC AND SHOULD NOT BE USED WITHOUT WRITTEN PERMISSION											
DIMENSION UNITS		SCALE		CURRENT REV DESC: NEW VIEW ADDED TO ILLUSTRATE THE USAGE OF SHOULDER SCREW IN PLACE OF SELF CLINCHING STANDOFF FOR PANEL MOUNTING IN SHEET 4							
mm		3:1									
GENERAL TOLERANCES (UNLESS SPECIFIED)											
ANGULAR TOL ± 0.5°											
4 PLACES ±				EC NO: 745616							
3 PLACES ±				DRWN: CHETAB 2023/03/10							
2 PLACES ± 0.15				CHK'D: GSHARMA 2023/04/28							
1 PLACE ± 0.25				APPR: HTHYAGARAJ 2023/05/05							
0 PLACES ±				INITIAL REVISION:							
				DRWN: CHETAB 2021/05/17							
				APPR: HTHYAGARAJ 2021/11/05							
DRAFT WHERE APPLICABLE MUST REMAIN WITHIN DIMENSIONS				THIRD ANGLE PROJECTION		DRAWING		SERIES		MATERIAL NUMBER	
				D-SIZE		215511		2155118121		CUSTOMER	
								GENERAL MARKET		SHEET NUMBER	
										2 OF 4	

molex

2CKT 8MM PANEL MOUNT RECEPTACLE HOUSING
POWERWIZE PRODUCT FAMILY

PRODUCT CUSTOMER DRAWING

DOCUMENT NUMBER	DOC TYPE	DOC PART	REVISION
2155118121	PSD	000	A2

PANEL MOUNT OF RECEPTACLE ASSEMBLY WITH SCREW AND SELF CLINCHING STANDOFF

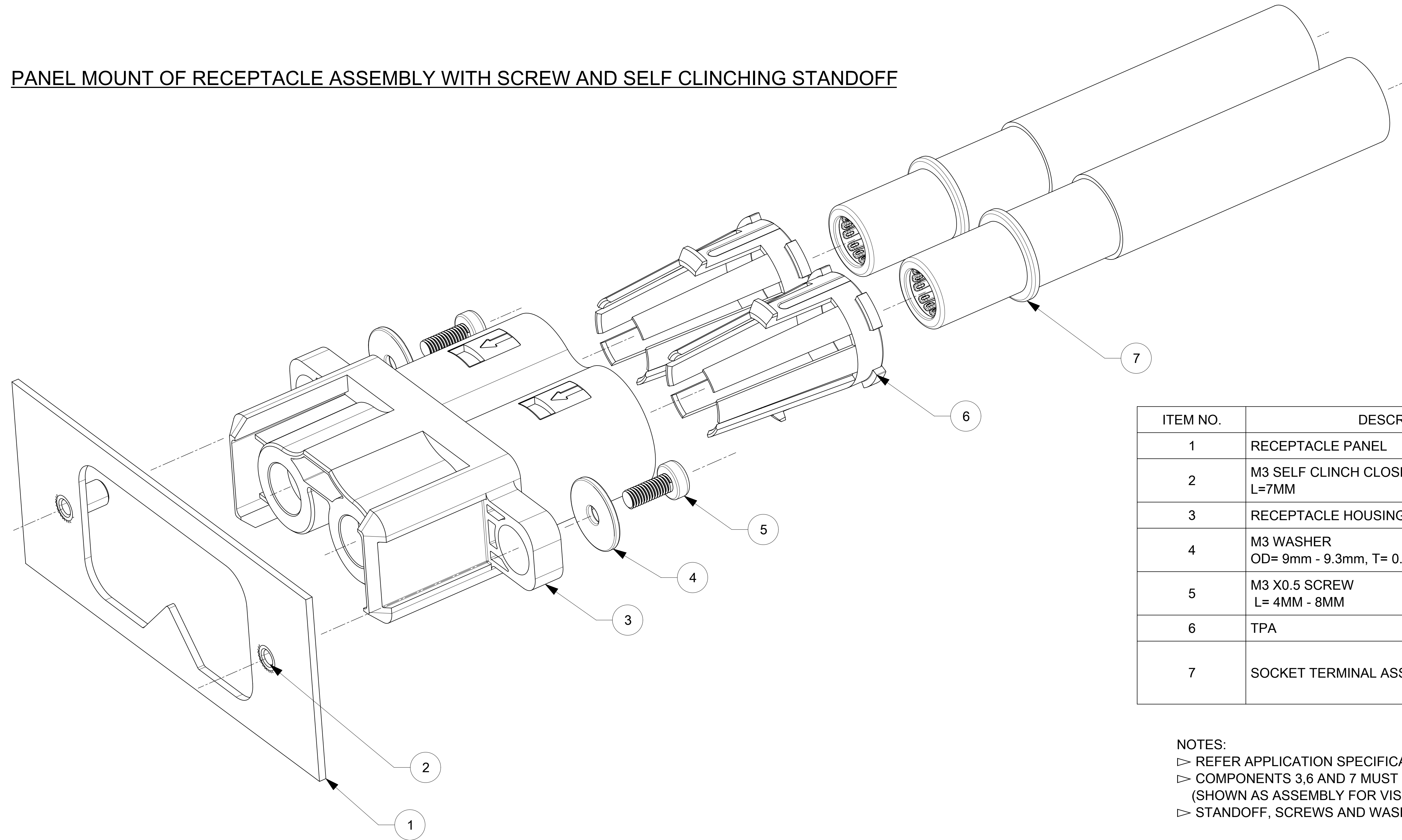

ITEM NO.	DESCRIPTION	QTY	REMARKS
1	RECEPTACLE PANEL	1	--
2	M3 SELF CLINCH CLOSE TO EDGE STANDOFF L=7MM	2	--
3	RECEPTACLE HOUSING	1	--
4	M3 WASHER OD= 9mm - 9.3mm, T= 0.5MM - 1.0MM	2	--
5	M3 X0.5 SCREW L= 4MM - 8MM	2	--
6	TPA	2	REFER SD: 2155138001
7	SOCKET TERMINAL ASSEMBLY	2	WIRE SIZE : 1/0 AWG REFER 2046080001-SD

NOTES:

- ▷ REFER APPLICATION SPECIFICATION 2155101000-AS FOR INSTALLATION INSTRUCTION
- ▷ COMPONENTS 3,6 AND 7 MUST TO BE PURCHASED INDIVIDUALLY
(SHOWN AS ASSEMBLY FOR VISUAL PURPOSE ONLY)
- ▷ STANDOFF, SCREWS AND WASHERS ARE NOT SUPPLIED BY MOLEX.

THIS DRAWING CONTAINS INFORMATION THAT IS PROPRIETARY TO MOLEX ELECTRONIC TECHNOLOGIES, LLC AND SHOULD NOT BE USED WITHOUT WRITTEN PERMISSION											
DIMENSION UNITS mm		SCALE 3:1		CURRENT REV DESC: NEW VIEW ADDED TO ILLUSTRATE THE USAGE OF SHOULDER SCREW IN PLACE OF SELF CLINCHING STANDOFF FOR PANEL MOUNTING IN SHEET 4				molex			
GENERAL TOLERANCES (UNLESS SPECIFIED)				EC NO: 745616							
ANGULAR TOL ± 0.5°		4 PLACES ±		DRWN: CHETAB 2023/03/10		CHK'D: GSHARMA 2023/04/28		PRODUCT CUSTOMER DRAWING			
3 PLACES ±		2 PLACES ± 0.15		APPR: HTHYAGARAJ 2023/05/05		INITIAL REVISION:		DOCUMENT NUMBER		DOC TYPE DOC PART REVISION	
1 PLACE ± 0.25		0 PLACES ±		DRWN: CHETAB 2021/05/17		APPR: HTHYAGARAJ 2021/11/05		2155118121		PSD 000 A2	
DRAFT WHERE APPLICABLE MUST REMAIN WITHIN DIMENSIONS				THIRD ANGLE PROJECTION		DRAWING		SERIES		SHEET NUMBER	
				D-SIZE		215511		2155118121		GENERAL MARKET 3 OF 4	

PANEL MOUNT OF RECEPTACLE ASSEMBLY WITH SHOULDER SCREW AND NUT

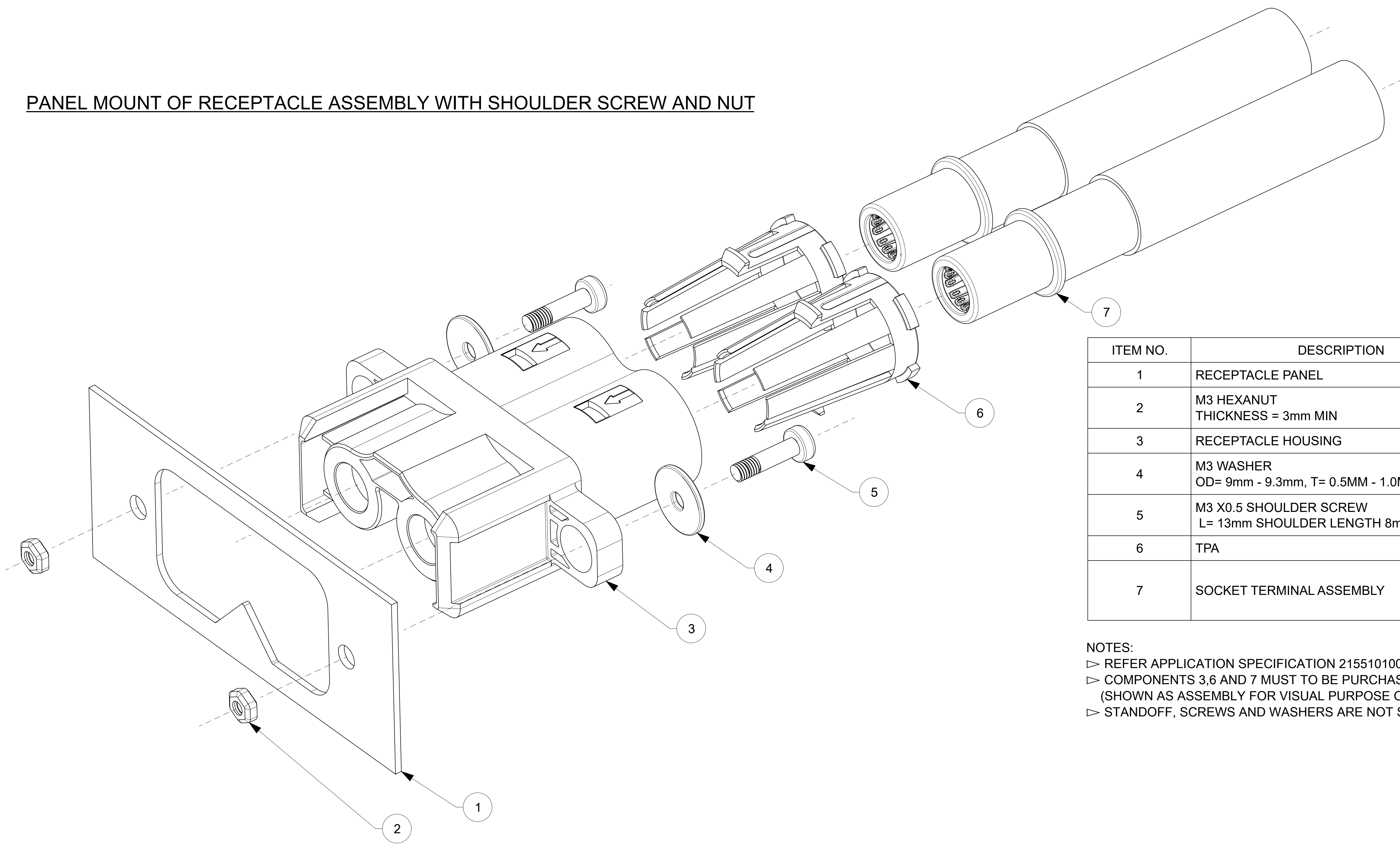

ITEM NO.	DESCRIPTION	QTY	REMARKS
1	RECEPTACLE PANEL	1	--
2	M3 HEXANUT THICKNESS = 3mm MIN	2	--
3	RECEPTACLE HOUSING	1	--
4	M3 WASHER OD= 9mm - 9.3mm, T= 0.5MM - 1.0MM	2	--
5	M3 X0.5 SHOULDER SCREW L= 13mm SHOULDER LENGTH 8mm MIN.	2	--
6	TPA	2	REFER SD: 2155138001
7	SOCKET TERMINAL ASSEMBLY	2	WIRE SIZE : 1/0 AWG REFER 2046080001-SD

NOTES:
 ▷ REFER APPLICATION SPECIFICATION 2155101000-AS FOR INSTALLATION INSTRUCTION
 ▷ COMPONENTS 3,6 AND 7 MUST TO BE PURCHASED INDIVIDUALLY
 (SHOWN AS ASSEMBLY FOR VISUAL PURPOSE ONLY)
 ▷ STANDOFF, SCREWS AND WASHERS ARE NOT SUPPLIED BY MOLEX.

THIS DRAWING CONTAINS INFORMATION THAT IS PROPRIETARY TO MOLEX ELECTRONIC TECHNOLOGIES, LLC AND SHOULD NOT BE USED WITHOUT WRITTEN PERMISSION											
DIMENSION UNITS mm		SCALE 3:1		CURRENT REV DESC: NEW VIEW ADDED TO ILLUSTRATE THE USAGE OF SHOULDER SCREW IN PLACE OF SELF CLINCHING STANDOFF FOR PANEL MOUNTING IN SHEET 4						molex	
GENERAL TOLERANCES (UNLESS SPECIFIED)				EC NO: 745616							
ANGULAR TOL		± 0.5°		4 PLACES		±		DRWN: CHETAB		2023/03/10	
3 PLACES		±		CHK'D: GSHARMA		2023/04/28		2CKT 8MM PANEL MOUNT RECEPTACLE HOUSING POWERWIZE PRODUCT FAMILY			
2 PLACES		± 0.15		APPR: HTHYAGARAJ		2023/05/05					
1 PLACE		± 0.25		INITIAL REVISION:		DRWN: CHETAB		2021/05/17		PRODUCT CUSTOMER DRAWING	
0 PLACES		±		APPR: HTHYAGARAJ		2021/11/05					
DRAFT WHERE APPLICABLE MUST REMAIN WITHIN DIMENSIONS				THIRD ANGLE PROJECTION		DRAWING		SERIES		DOCUMENT NUMBER	
D-SIZE		215511		MATERIAL NUMBER		CUSTOMER		REVISION		SHEET NUMBER	
2155118121		GENERAL MARKET		PSD		000		A2		4 OF 4	