

Keywords: rf, rfic, gps if filter, simulated, butterworth, response, GPS, cascaded gain, noise figure, rf ics, radio frequency, rfics

APPLICATION NOTE 2242

MAX2538 Uses GPS IF LC filter Optimized for 183.6MHz IF

Sep 26, 2003

Abstract: This application note presents the design of a GPS IF filter at 183.6MHz for use with the MAX2538. Simulated and measured response and performance data are provided. The filter is Butterworth response, second order, with capacitor coupling. Insertion loss is 3.2dB. The GPS cascaded gain is 28.9dB, and the noise figure is 1.8dB.

General Description of MAX2538

The MAX2538 LNAs (low noise amplifiers) and mixers are optimized for CDMA (code division multiple access) applications in the cellular and PCS bands. The MAX2538 addresses triple-band, quad-mode applications by providing switched signal paths for AMPS, digital cellular, and digital PCS. The mixers provide switched IF ports that can be used interchangeably with either mixer input port. In addition, all versions in the family provide an LNA/Mixer/LO (local oscillator) path for GPS (global positioning system) down conversion.



[Click here for an overview of the wireless components used in a typical radio transceiver.](#)

Objective

Design a second-order, 1k Ω , capacitor-coupled, Butterworth LC filter for a GPS IF at 183.6MHz to eliminate the use of an IF SAW filter. This solution saves cost and printed circuit board (PCB) area.

Step 1:

For simplicity and design speed, filter design software is used. In this example, Filter Solutions 8.1* was used.

The Filter design parameters are:

2nd order Bandpass Butterworth, capacitor-coupled filter
 $F_C = 183.6\text{MHz}$
 $BW = 15\text{MHz}$
 $Z_{IN} = Z_{OUT} = 1\text{k}\Omega$
Inductor Q = 35–50
Capacitor Q = 350–500

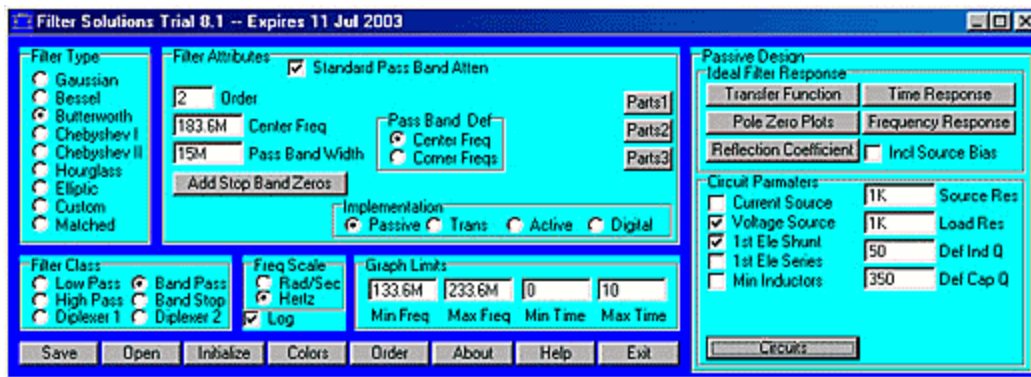

Figure 1.

The circuit below (Figure 2) and the frequency response (Figure 3) are the results obtained with Filter Solutions software. The light-blue, upper traces shown in Figure 3 are for a filter with lossless components. The red trace depicts the expected performance with lossy components.

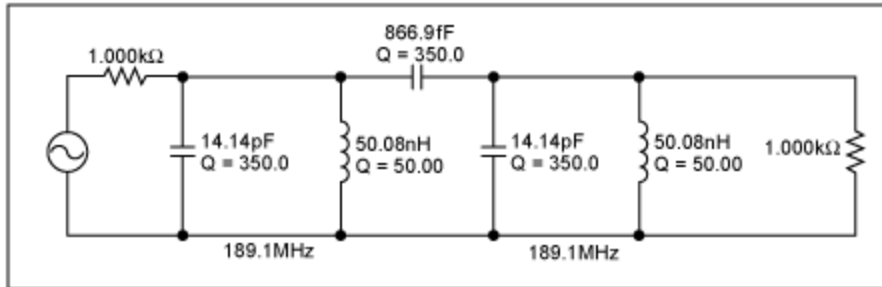

Figure 2.

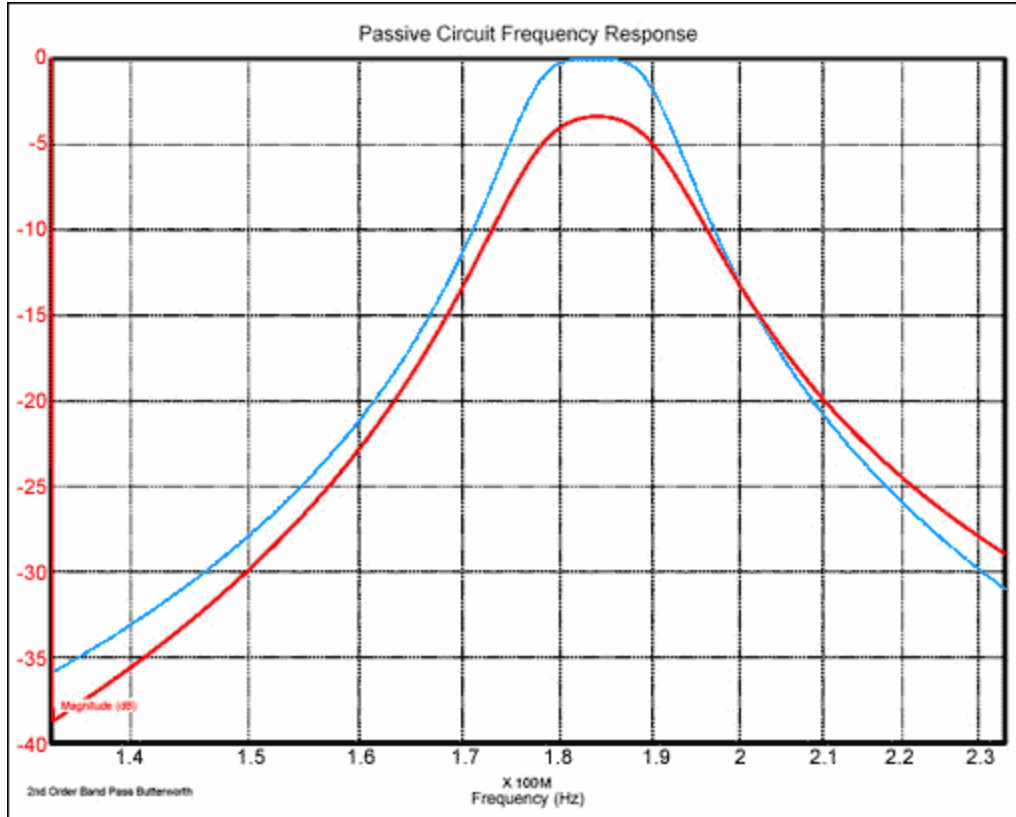

Figure 3.

Step 2:

Use the MAX2538 GPS Mixer model to design the matching network between the MAX2538 GPS differential mixer outputs (pin 20 and 21) and the 1kΩ IF filter.

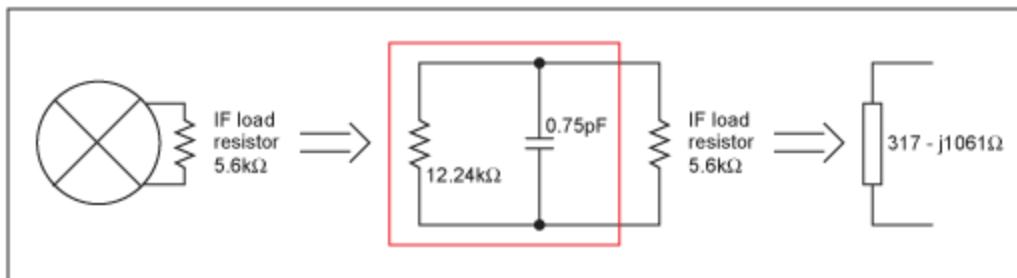

Figure 4.

Step 3:

Use a High Frequency Circuit Simulator to simulate the frequency response of the GPS IF filter matched to the GPS IF filter. Agilent ADS 2002 was used for this example. To reduce the number of passive components and reduce the insertion loss, integrate one resonant tank (the resonator on the input side) with the matching network required to match the mixer's output impedance to the 1kΩ filter.

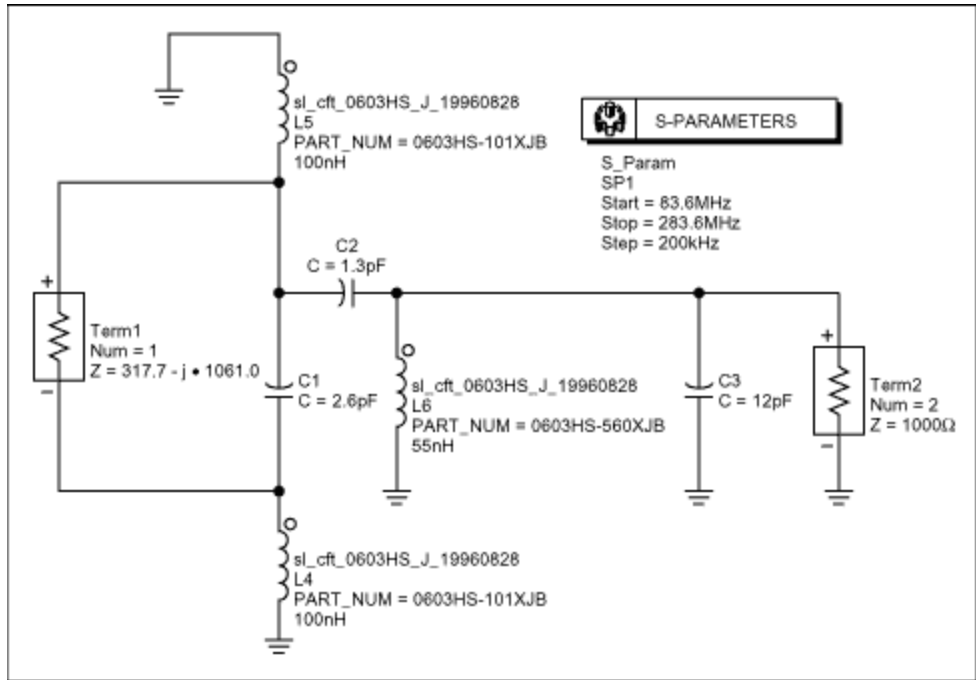

Figure 5.

Figure 6 is the frequency response of the GPS IF Filter matched to the MAX2538 GPS Mixer.

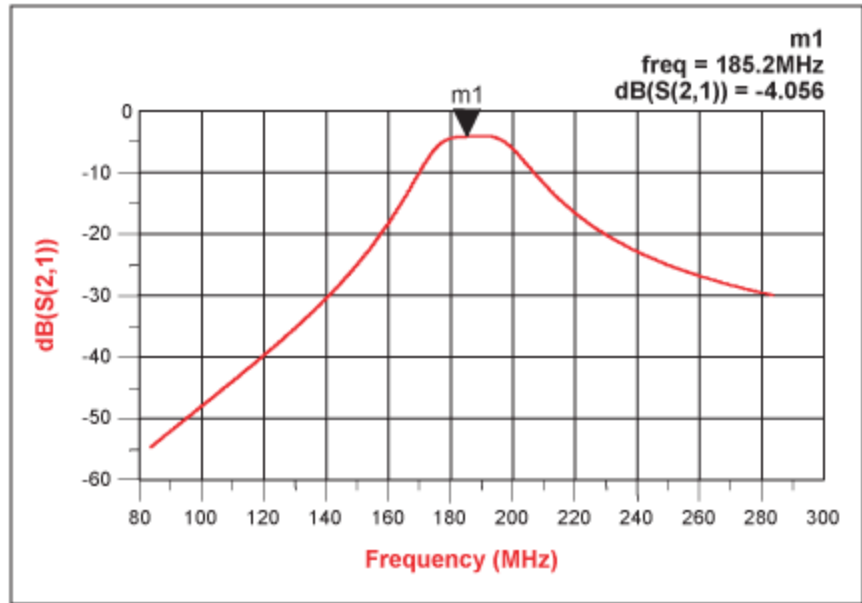

Figure 6.

Step 4:

After implementing the circuit obtained in Agilent ADS, the cascaded measurement of the MAX2538 from the GPS LNA input to the GPS IF filter output was performed.

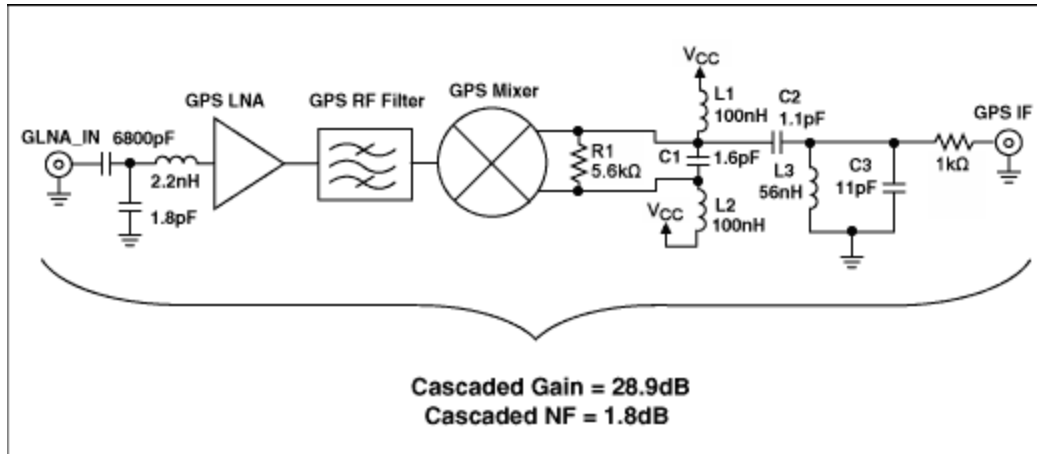

Figure 7.

Test Conditions

$V_{CC} = 2.85V$

$F_{RF} = 1575.42MHz$, $PIN_{RF} = -40dBm$

$IF = 183.6MHz$

$F_{LO} = 2087.73MHz$, $PIN_{LO} = -7dBm$

GPS LNA gain = 17.5dB

GPS mixer gain = 10dB

GPS RF SAW filter loss = -1.8dB

The 1kΩ resistor at the output is used for measurement purposes only, since the output of the filter is 1kΩs. To calculate cascaded gain, add the measured gain to the attenuation introduced by the mismatch between 50Ωs and 1050Ωs.

$$\text{Attenuation} = 0.5 \times |20\log(50 / 1050)| = 13.22dB$$

Cascaded gain = measured gain + $0.5 \times |20\log(50 / 1050)|$ from LNA input to 1kΩ output (GPS IF output).

$$\text{Cascaded gain} = 15.7dB + 13.22dB = 28.9dB$$

$$\text{Cascaded gain} = \text{LNA gain} + \text{RF filter loss} + \text{mixer gain} + \text{IF filter loss} = 28.9dB$$

$$\text{Discrete GPS IF filter loss} = +28.9dB - 17.5dB + 1.8dB - 10.0dB = 3.2dB$$

Cascaded NF is measured from LNA input to 1kΩ output (GPS IF output).

$$\text{Cascaded NF} = 1.8dB$$

Component values used in the IF section:

C1 = 1.6pF ±0.1pF GRM36COG1R6B050 Murata (0402)

C2 = 1.1pF ±0.1pF GRM36COG1R1B050 Murata (0402)

C3 = 11pF ±0.1pF GJ61555C1H110JB01B Murata (0402)

L1, L2 = 100nH 0603CS-R10XJB CoilCraft (0603)

L3 = 56nH \pm 5% 0603CS-56NXJB CoilCraft (0603)

R1 = 5.6k Ω \pm 1%

*Filter Solutions by Nuhertz Technologies, L.L.C., <http://www.filter-solutions.com>

Related Parts

[MAX2538](#)

Quadruple-Mode PCS/Cellular/GPS LNA/Mixers

More Information

For Technical Support: <http://www.maximintegrated.com/support>

For Samples: <http://www.maximintegrated.com/samples>

Other Questions and Comments: <http://www.maximintegrated.com/contact>

Application Note 2242: <http://www.maximintegrated.com/an2242>

APPLICATION NOTE 2242, AN2242, AN 2242, APP2242, Appnote2242, Appnote 2242

Copyright © by Maxim Integrated Products

Additional Legal Notices: <http://www.maximintegrated.com/legal>