

RECOMMENDED PCB LAY OUT
[GENERAL TOLERANCE ±0.05]

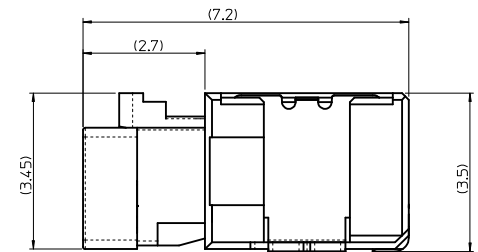

MATED CONDITION (REF.)

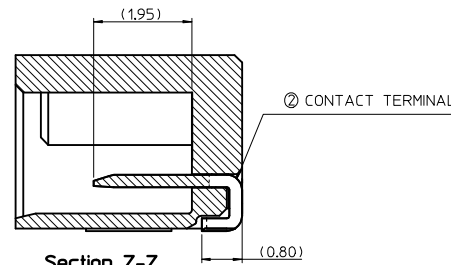
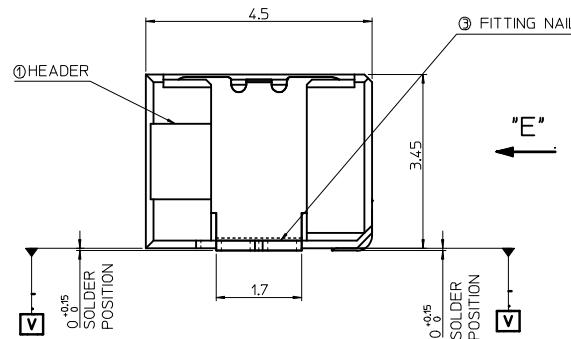
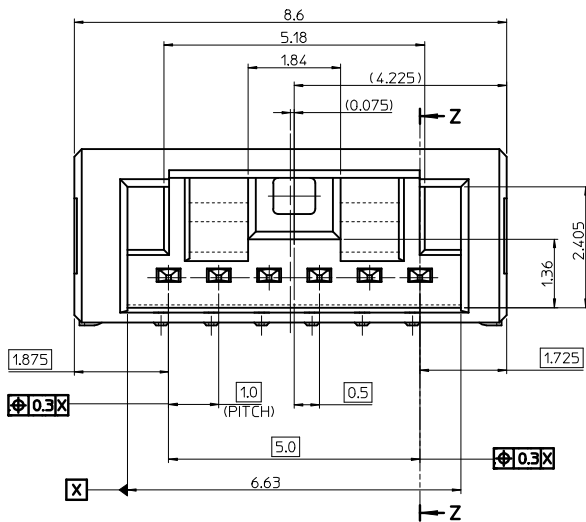

Section Z-Z

NOTES.

- MATED WITH : 104192-0600
- MATERIALS.
 - ①- HEADER : LIQUID CRYSTAL POLYMER(LCP)
 - GLASS FILLED, UL 94V-0, HALOGEN FREE, COLOR OF NATURAL
 - ②- CONTACT TERMINAL : PHOSPHOR BRONZE
 - 0.25mm THICKNESS
 - ③- FITTING NAIL : BRASS, 0.2mm THICKNESS
- FINISHES.
 - ②- CONTACT TERMINAL : PURE-TIN PLATING ON OVERALL.
 - THICKNESS : 1.5µm~4.0µm
 - UNDER PLATING Ni OVERALL.
 - THICKNESS : 1.25µm~3.75µm
 - ③- FITTING NAIL : PURE-TIN PLATING ON OVERALL.
 - THICKNESS : 3.0µm~5.0µm
 - UNDER PLATING Ni OVERALL.
 - THICKNESS : 1.25µm~3.75µm
- COPLANALITH OF SOLDER TAIL (PEAK TEMP. : 260°C) BEFORE & AFTER REFLOW : 0.08MAX

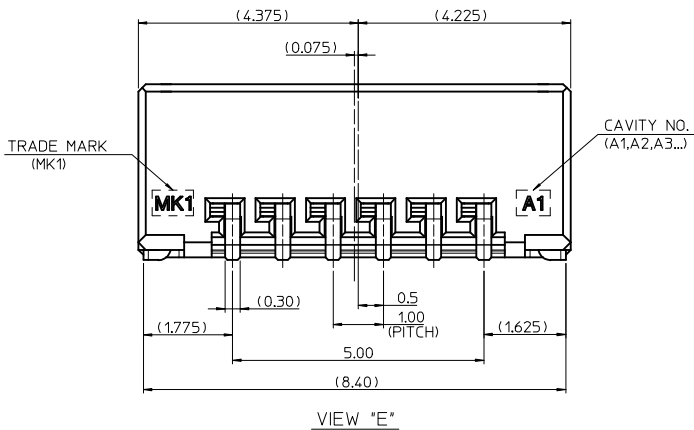

VIEW "E"

RELEASED EC NO: KOR2015-0017 DRWN: JSSHIN 2014/08/19 CHKD: SHCHU 2014/08/19 APPR: YSK1M02 2014/08/25	QUALITY SYMBOLS ▽=0 ▽=0	GENERAL TOLERANCES (UNLESS SPECIFIED)		DIMENSION STYLE MM ONLY		SCALE 10/1	DESIGN UNITS METRIC	THIRD ANGLE PROJECTION		
		mm	INCH	DRAWN BY JB JIN	DATE 2013/02/18	TITLE 1.0MM W-T-B CONN. HEADER ASS'Y -6P (RIGHT ANGLE TYPE)				
REV A	DESCRIPTION	4 PLACES	± 0.15	± 0.006	CHECKED BY SHCHU	DATE 2013/02/18				
		3 PLACES	± 0.15	± 0.006	APPROVED BY YSK1M02	DATE 2014/08/25				
		2 PLACES	± 0.15	± 0.006	MATERIAL NO. 1041930610					
		1 PLACE	± 0.20	± 0.008	DOCUMENT NO. SD-104193-001					
		0 PLACE	± 0.20	± 0.008	SHEET NO. 1 OF 1		THIS DRAWING CONTAINS INFORMATION THAT IS PROPRIETARY TO MOLEX INCORPORATED AND SHOULD NOT BE USED WITHOUT WRITTEN PERMISSION			

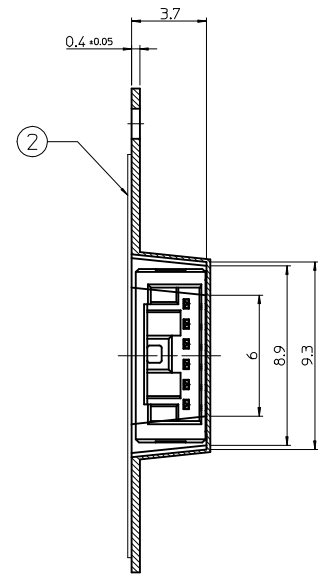
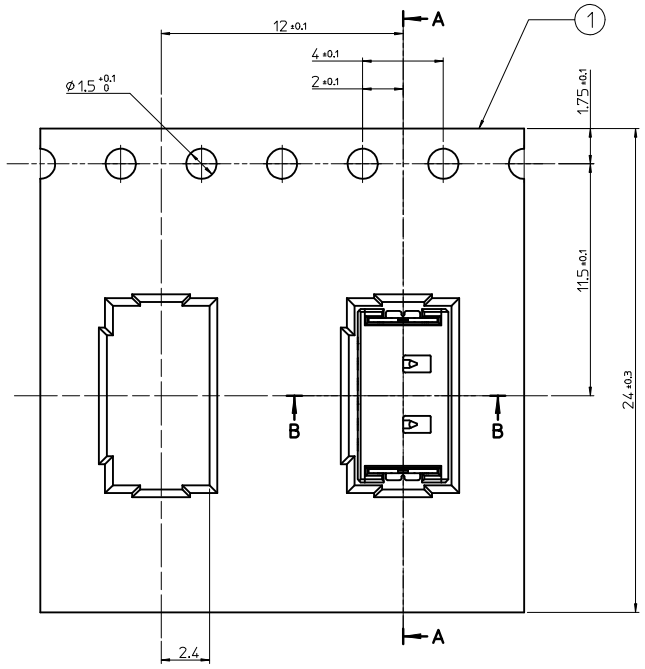

Section A-A

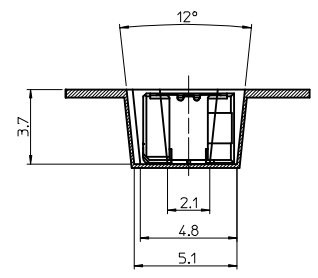

Section B-B

NOTES

1. QUANTITY OF CONNECTORS : 2,000 PCS/REEL
2. LEAD LENGTH
3. PEELING OFF FORCE OF COVER TAPE : 0.1N~0.59N(10.2GF~60GF)
 (PEELING DIRECTION AS SHOW IN FOLLOW FIG.)
 PEELING OFF SPEED : 300mm/Min.(Ref.)
4. FLASH IN ANY PORTION SHOULD BE LESS THAN 0.20mm MAX.
5. UNLESS OTHERWISE SPECIFIED INNER R0.2 MAX

[TABLE]

1041930610	104193-0610	NATURAL	24.0mm	104193-9001
MATERIAL NO.	NO.	COLOR	TAPE WIDTH	EMBOSS TAPE
	CONNECTOR			

3	PLASTIC BOBBIN	HI P.S	WHITE
2	COVER TAPE	PET ANTISTATIC	21.3m
1	CARRIER (EMBOSS) TAPE	PET ANTISTATIC	
NO.	DESCRIPTION	MATERIAL	REMARK

PULL OUT DIRECTION →

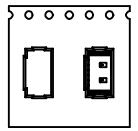

PULL OUT DIRECTION →

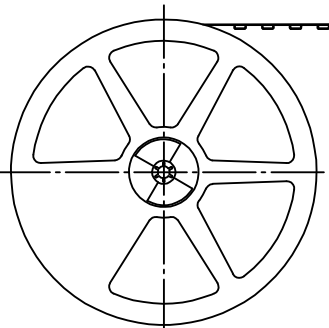

PLASTIC BOBBIN

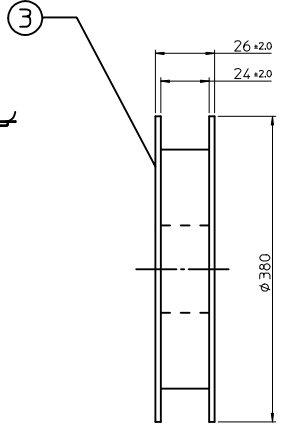

PRELIMINARY EC NO: KOR2014-0085 DRWN: JSSHIN 2013/12/31 CHKD: SHCHU 2013/12/31 APPR: YSK1M02 2014/01/02	QUALITY SYMBOLS	GENERAL TOLERANCES (UNLESS SPECIFIED)	DIMENSION STYLE	SCALE	DESIGN UNITS	THIRD ANGLE PROJECTION
	▽=0 □=0	mm INCH 4 PLACES ± --- ± --- 3 PLACES ± --- ± --- 2 PLACES ± 0.20 ± --- 1 PLACE ± 0.20 ± --- 0 PLACE ± --- ± ---	MM ONLY	4/1	METRIC	
	ANGULAR ± 3 °	DRAFT WHERE APPLICABLE MUST REMAIN WITHIN DIMENSIONS	DRAWN BY	DATE	TITLE	
			JB JIN	2013/04/10	1.0MM W-T-B CONN. HEADER ASS'Y -6P EMBOSS PACKAGE	
		CHECKED BY	DATE			
		SHCHU	2013/04/10			
		APPROVED BY	DATE			
		YSK1M02	2014/01/02			
		MATERIAL NO.	1041930610	DOCUMENT NO.	SD-104193-003	SHEET NO. 1 OF 1
		SIZE	A3	THIS DRAWING CONTAINS INFORMATION THAT IS PROPRIETARY TO MOLEX INCORPORATED AND SHOULD NOT BE USED WITHOUT WRITTEN PERMISSION		