

UJA1162A

Self-supplied high-speed CAN transceiver with Sleep mode

Rev. 1 — 23 August 2019

Product data sheet

1. General description

The UJA1162A is a 'self-supplied' high-speed CAN transceiver integrating an ISO 11898-2:2016 and SAE J2284-1 to SAE J2284-5 compliant HS-CAN transceiver and an internal 5 V CAN supply. The only supply input is a battery connection. The UJA1162A can be operated in very-low-current Sleep mode with local and bus wake-up capability.

This implementation enables reliable communication in the CAN FD fast phase at data rates up to 5 Mbit/s.

2. Features and benefits

2.1 General

- Self-supplied ISO 11898-2:2016 and SAE J2284-1 to SAE J2284-5 compliant high-speed CAN transceiver
- Hardware and software compatible with the UJA116x product family and with improved EMC performance
- Loop delay symmetry timing enables reliable communication at data rates up to 5 Mbit/s in the CAN FD fast phase
- Autonomous bus biasing according to ISO 11898-6
- Fully integrated 5 V supply (V_{BUF}) for the CAN transmitter/receiver
- VIO input allows for direct interfacing with 3.3 V to 5 V microcontrollers
- Bus connections are truly floating when power to pin BAT is off

2.2 Designed for automotive applications

- ± 8 kV ElectroStatic Discharge (ESD) protection, according to the Human Body Model (HBM) on the CAN bus pins
- ± 6 kV ESD protection, according to IEC TS 62228 on the CAN bus pins and on pins BAT and WAKE
- CAN bus pins short-circuit proof to ± 58 V
- Battery and CAN bus pins are protected against automotive transients according to ISO 7637-3
- Very low quiescent current in Sleep mode
- Leadless HVSON14 package (3 mm \times 4.5 mm) with improved Automated Optical Inspection (AOI) capability
- Dark green product (halogen free and Restriction of Hazardous Substances (RoHS) compliant)



2.3 Integrated supply voltage for the CAN transceiver (V_{BUF})

- 5 V nominal output; $\pm 2\%$ accuracy
- Undervoltage detection at 90 % of nominal value
- Excellent response with a 4.7 μ F ceramic output load capacitor
- Turned off in Sleep mode

2.4 Power Management

- Sleep mode featuring very low supply current
- Remote wake-up capability via standard CAN wake-up pattern
- Local wake-up capability via the WAKE pin
- Entire node can be powered down via the inhibit output, INH

2.5 System control and diagnostic features

- Mode control via SLPN pin
- Overtemperature shutdown
- Transmit data (TXD) dominant time-out function

3. Ordering information

Table 1. Ordering information

| Type number | Package | | Version |
|-------------|---------|--|-----------|
| | Name | Description | |
| UJA1162ATK | HVSON14 | plastic thermal enhanced very thin small outline package; no leads; 14 terminals; body 3 × 4.5 × 0.85 mm | SOT1086-2 |

4. Block diagram

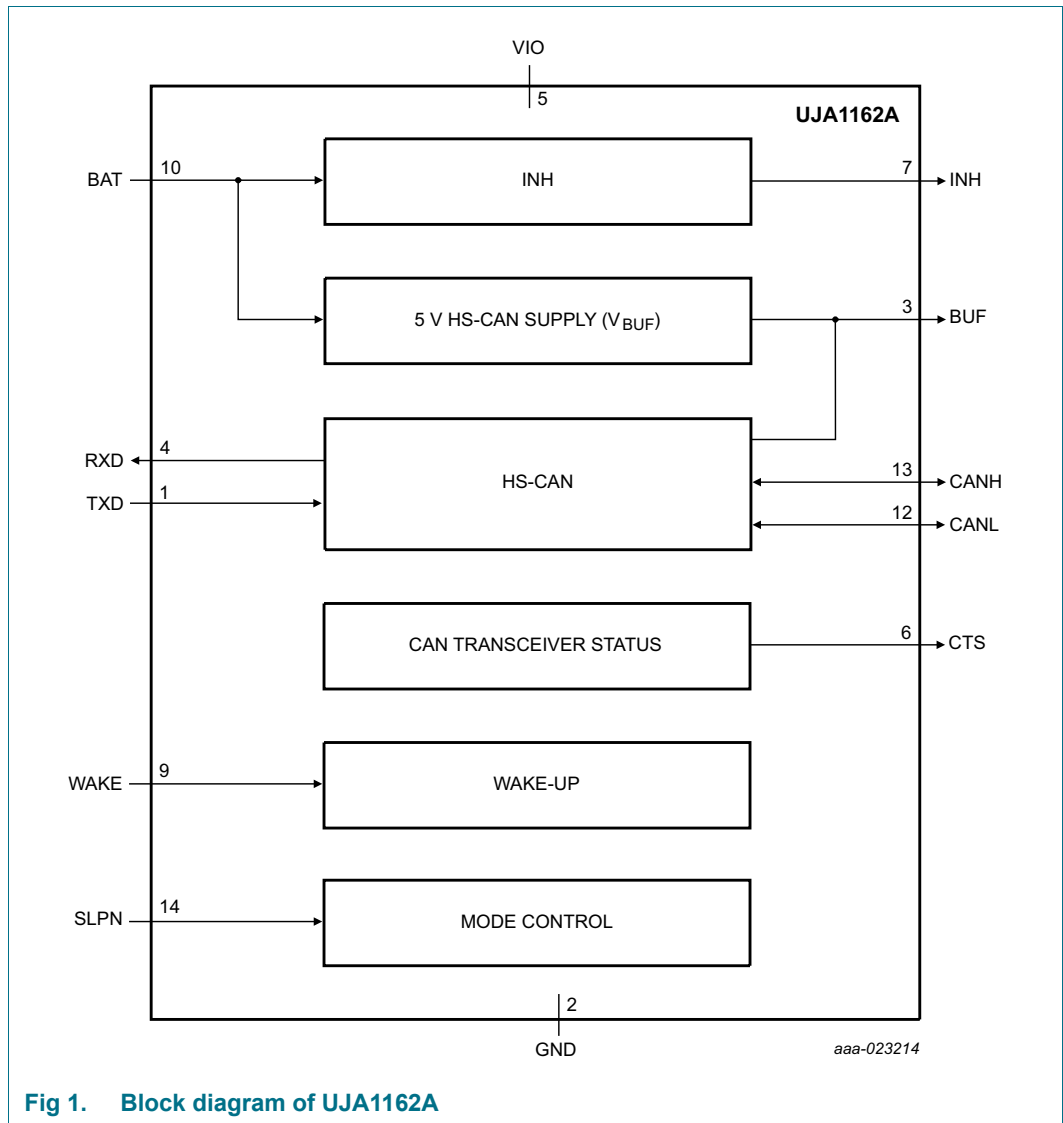
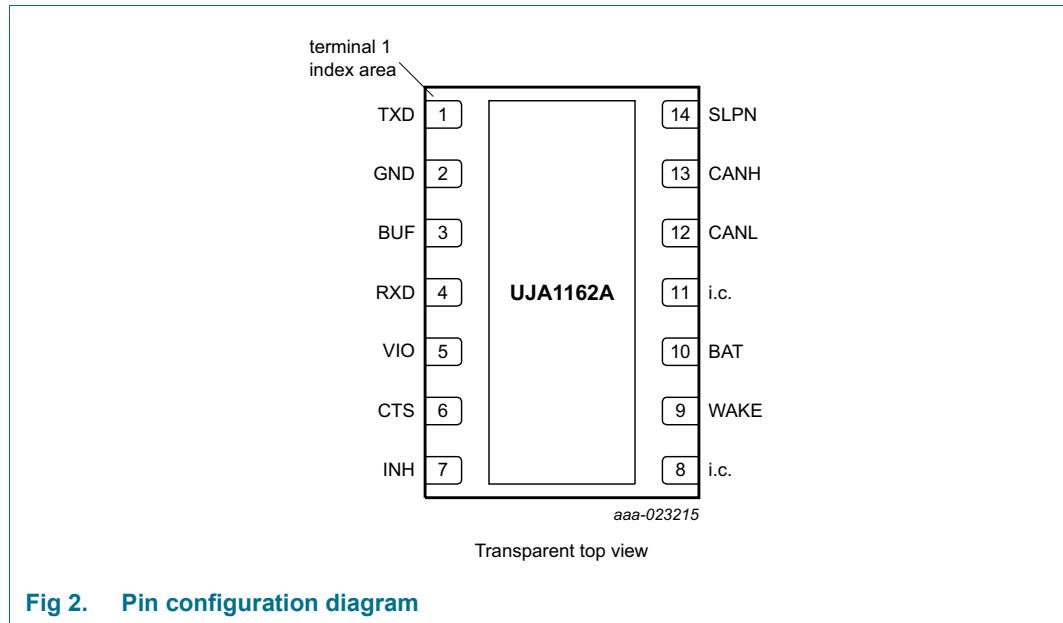

Fig 1. Block diagram of UJA1162A

5. Pinning information

5.1 Pinning



5.2 Pin description

Table 2. Pin description

| Symbol | Pin | Description |
|--------|------------------|---|
| TXD | 1 | transmit data input |
| GND | 2 ^[1] | ground |
| BUF | 3 | 5 V transceiver supply voltage |
| RXD | 4 | receive data output; reads out data from the bus lines |
| VIO | 5 | supply voltage for I/O level adaptor |
| CTS | 6 | CAN transceiver status output |
| INH | 7 | inhibit output for switching external voltage regulators |
| i.c. | 8 | internally connected; should be left floating or connected to GND |
| WAKE | 9 | local wake-up input |
| BAT | 10 | battery supply voltage |
| i.c. | 11 | internally connected; should be left floating or connected to GND |
| CANL | 12 | LOW-level CAN bus line |
| CANH | 13 | HIGH-level CAN bus line |
| SLPN | 14 | Sleep mode control input (active LOW) |

[1] The exposed die pad at the bottom of the package allows for better heat dissipation and grounding from the transceiver via the printed circuit board. For enhanced thermal and electrical performance, it is recommended to solder the exposed die pad to GND.

6. Functional description

The UJA1162A is a self-supplied high-speed CAN transceiver incorporating a 5 V CAN supply. A variety of fail-safe and diagnostic features offer enhanced system reliability and advanced power management.

6.1 System controller

The system controller is a state machine that manages register configuration and controls the internal functions of the UJA1162A. UJA1162A operating modes and state transitions are illustrated in [Figure 3](#). These modes are discussed in more detail in the following sections.

6.1.1 Operating modes

The UJA1162A supports five operating modes: Normal, Standby, Sleep, Overtemp and Off.

6.1.1.1 Normal mode

Normal mode is the active operating mode. In this mode, the UJA1162A is fully operational. Normal mode can be selected from Standby and Sleep (via Standby) modes by setting pin SLPN HIGH, provided $V_{IO} > V_{uvd}(V_{IO})$. The UJA1162A exits Normal mode:

- if the microcontroller selects Standby mode by setting pin SLPN LOW
- if the UJA1162A detects an undervoltage on VIO, causing the UJA1162A to switch to Standby mode
- if the chip temperature rises above $T_{th(act)otp}$, causing the UJA1162A to switch to Overtemp mode
- if the battery supply voltage drops below $V_{th(det)poff}$, causing the UJA1162A to switch to Off mode

All pending wake-up events (power-on, CAN bus wake-up, local wake-up via the WAKE pin) are cleared when the UJA1162A enters Normal mode.

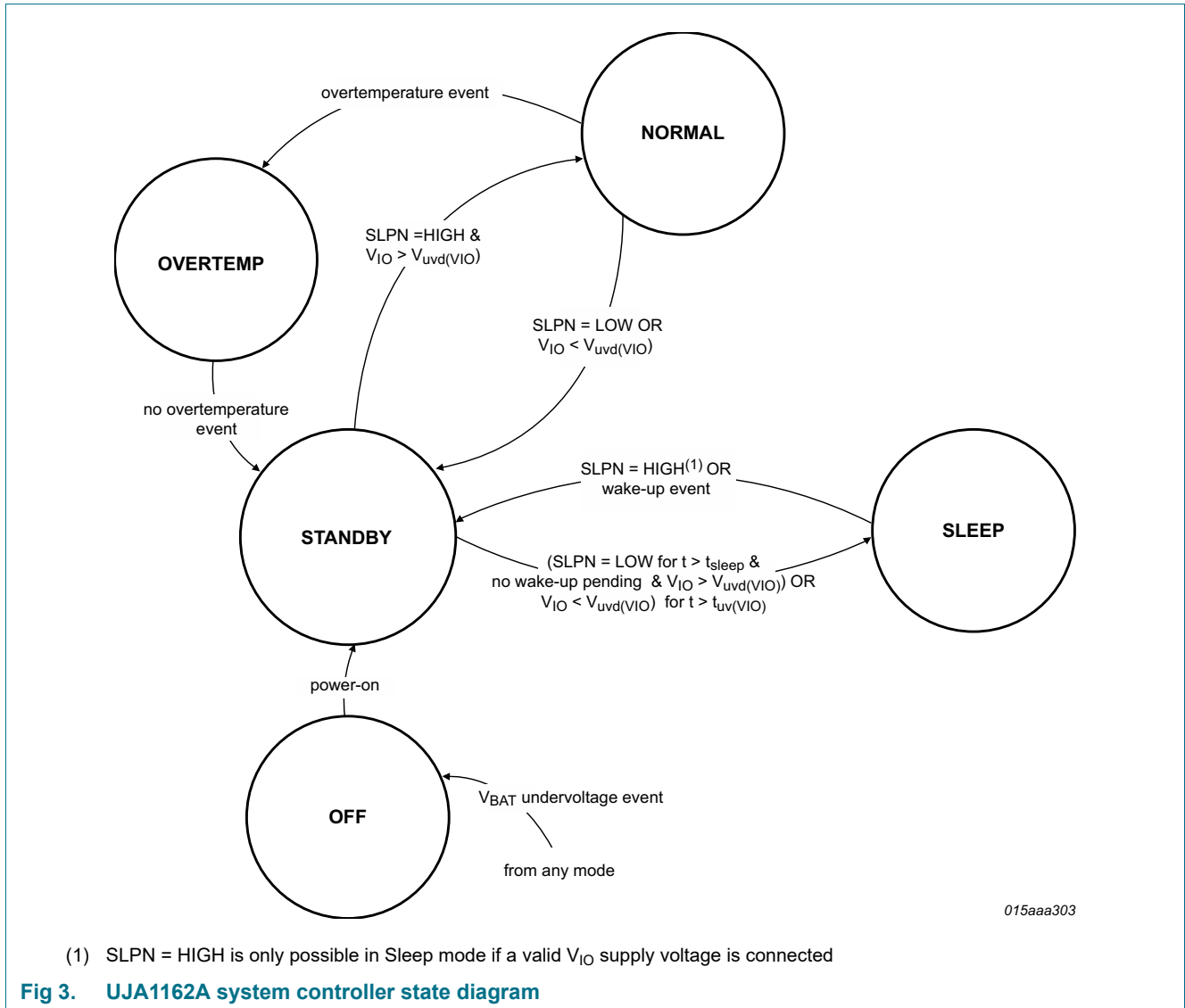

Fig 3. UJA1162A system controller state diagram

6.1.1.2 Standby mode

Standby mode is a transitional mode between Normal and Sleep modes. The transceiver is unable to transmit or receive data in Standby mode, but pin INH is active.

The receiver monitors bus activity for a wake-up request in Standby mode. The bus pins are biased at GND level (via $R_{i(cm)}$) when the bus is inactive for $t > t_{to(silence)}$ and at approximately 2.5 V when there is activity on the bus (autonomous biasing). Wake-up can be triggered remotely via a standard wake-up pattern on the CAN bus (see [Section 6.3.2](#)) or locally via the WAKE pin. Pin RXD is forced LOW when a bus or local wake-up event is detected.

The UJA1162A switches to Standby mode:

- from Normal mode if pin SLPN goes LOW or and undervoltage is detected on VIO
- from Sleep mode in the event of a local or remote wake-up event or if SLPN = HIGH (with a valid voltage on VIO)

6.1.1.3 Sleep mode

Sleep mode is the power-saving mode of the UJA1162A. In Sleep mode, the transceiver behaves as in Standby Mode, with the exception that pin INH is set floating and temperature protection is inactive. Voltage regulators controlled by this pin are switched off, and the current into pin BAT is reduced to a minimum.

A HIGH level on SLPN (provided a valid voltage is present on VIO), a local wake-up via the WAKE pin or a remote CAN bus wake-up will cause the UJA1162A to wake up from Sleep mode and switch to Standby mode. Pin RXD is forced LOW when a local wake-up via WAKE or a remote bus wake-up is detected.

The UJA1162A can be set to Sleep mode by holding pin SLPN LOW for $t > t_{\text{sleep}}$ (provided there are no wake-up events pending). If one or more wake-up events is pending, the UJA1162A will remain in Standby mode. The UJA1162A must be switched to Normal mode to clear pending wake-up events.

The UJA1162A will also be forced to Sleep mode if an undervoltage lasting longer than $t_{\text{d(uvd-slp)}}$ is detected on VIO ($V_{\text{IO}} < V_{\text{uvd(VIO)}}$). In this event, all pending wake-up events will be cleared automatically.

6.1.1.4 Off mode

The UJA1162A switches to Off mode from any mode when $V_{\text{BAT}} < V_{\text{th(det)poff}}$. Only power-on detection is enabled; all other modules are inactive. The UJA1162A starts to boot up when the battery voltage rises above the power-on detection threshold $V_{\text{th(det)pon}}$ (triggering an initialization process) and switches to Standby mode after t_{startup} . Pin RXD is driven LOW when the UJA1162A switches from Off mode to Standby mode, to indicate a power-on event has occurred.

In Off mode, the CAN pins disengage from the bus (zero load; high-ohmic).

6.1.1.5 Overtemp mode

Overtemp mode is provided to prevent the UJA1162A being damaged by excessive temperatures. The UJA1162A switches immediately to Overtemp mode from Normal mode when the global chip temperature rises above the overtemperature protection activation threshold, $T_{\text{th(act)otp}}$.

In Overtemp mode, the CAN transmitter and receiver are disabled and the CAN pins are in a high-ohmic state. No wake-up event will be detected, but a pending wake-up will still be signalled by a LOW level on pin RXD, which will persist after the overtemperature event has been cleared. V_{BUF} is off in Overtemp mode. INH remains unchanged.

The UJA1162A exits Overtemp mode:

- and switches to Standby mode if the chip temperature falls below the overtemperature protection release threshold, $T_{\text{th(rel)otp}}$
- if the device is forced to switch to Off mode ($V_{\text{BAT}} < V_{\text{th(det)poff}}$)

6.1.1.6 Hardware characterization for the UJA1162A operating modes

Table 3. Hardware characterization by functional block

| Block | Operating mode | | | | |
|------------------|-----------------------|---|------------------------|---|---|
| | Off | Standby | Normal | Overtemp | Sleep |
| V _{BUF} | off | on/off ^[1] | on | off | off |
| CAN | off | Offline | Active | off | Offline |
| RXD | V _{IO} level | V _{IO} level/LOW if wake-up detected | CAN bit stream | V _{IO} level/LOW if wake-up detected | V _{IO} level/LOW if wake-up detected |
| INH | off | V _{BAT} level | V _{BAT} level | V _{BAT} level | off |

[1] V_{BUF} is switched on in Standby mode if a CAN wake-up pattern is detected on the bus; if pin SLPN does not go HIGH within t_{to(silence)}, V_{BUF} is switched off again. V_{BUF} is also switched on in Standby mode if SLPN goes HIGH to select Normal mode.

6.1.2 Mode control via pin SLPN

The UJA1162A can be switched between Normal and Standby/Sleep modes via the SLPN control input (see Figure 3). When SLPN goes LOW, the UJA1162A switches to Standby mode. If SLPN remains low for t_{sleep}, the UJA1162A then switches to Sleep mode (if no wake-up is pending). When SLPN goes HIGH, the UJA1162A switches to Normal mode.

6.2 Power supplies

6.2.1 Battery supply voltage (V_{BAT})

The internal circuitry is supplied from the battery via pin BAT. The device needs to be protected against negative supply voltages, e.g. by using an external series diode. If V_{BAT} falls below the power-off detection threshold, V_{th(det)po}, the UJA1162A switches to Off mode, which means that the internal 5 V CAN supply and other internal logic (except for power-on detection) are shut down.

The UJA1162A switches from Off mode to Standby mode t_{startup} after the battery voltage rises above the power-on detection threshold, V_{th(det)pon}. A power-on event is indicated by a LOW level on pin RXD. RXD remains LOW from the moment UJA1162A exits Off mode until it switches to Normal mode.

6.2.2 CAN supply voltage (V_{BUF})

V_{BUF} provides the internal CAN transceiver with a 5 V supply. The output voltage on BUF is monitored. If V_{BUF} falls below the 90 % undervoltage threshold (90 % of the nominal V_{BUF} output voltage), the CAN transceiver switches to (or remains in) Offline mode.

6.3 High-speed CAN transceiver

The integrated high-speed CAN transceiver is designed for active communication at bit rates up to 1 Mbit/s, providing differential transmit and receive capability to a CAN protocol controller. The transceiver is ISO 11898-2:2016 compliant. The CAN transmitter is supplied from V_{BUF}. The UJA1162A includes additional timing parameters on loop delay symmetry to ensure reliable communication in fast phase at data rates up to 5 Mbit/s, as used in CAN FD networks.

The CAN transceiver supports autonomous CAN biasing, which helps to minimize RF emissions. CANH and CANL are always biased to 2.5 V when the UJA1162A is in Normal mode with V_{BUF} > 90 % threshold. Autonomous biasing is active when the UJA1162A is in

Standby or Sleep mode with the CAN transceiver in CAN Offline mode - to 2.5 V if there is activity on the bus (CAN Offline Bias mode) and to GND if there is no activity on the bus for $t > t_{to(silence)}$ (CAN Offline mode). This is useful when the node is disabled due to a malfunction in the microcontroller. The transceiver ensures that the CAN bus is correctly biased to avoid disturbing ongoing communication between other nodes. The autonomous CAN bias voltage is derived directly from V_{BAT} .

6.3.1 CAN operating modes

The integrated CAN transceiver supports three operating modes: Active, Offline and Offline Bias (see [Figure 5](#)). The CAN transceiver operating mode depends on the UJA1162A operating mode and the output voltage on pin BUF.

6.3.1.1 CAN Active mode

In CAN Active mode, the transceiver can transmit and receive data via CANH and CANL. The differential receiver converts the analog data on the bus lines into digital data, which is output on pin RXD. The transmitter converts digital data generated by the CAN controller (input on pin TXD) into analog signals suitable for transmission over the CANH and CANL bus lines.

The CAN transceiver is in Active mode when:

- the UJA1162A is in Normal mode (SLPN = 1) AND
- $V_{BUF} > V_{uvd(BUF)}$ AND
- $V_{IO} > V_{uvd(VIO)}$

In CAN Active mode, the CAN bias voltage is derived from V_{BUF} . If V_{BUF} falls below $V_{uvd(BUF)}$, the UJA1162A exits CAN Active mode and enters CAN Offline Bias mode with autonomous CAN voltage biasing via pin BAT.

If pin TXD is LOW when the transceiver switches to CAN Active mode (UJA1162A in Normal mode; V_{BUF} and V_{IO} ok), the transmitter and receiver will remain disabled until TXD goes HIGH. This prevents network traffic being blocked for $t_{to(dom)TXD}$ (i.e. while the TXD dominant time-out timer is running; see [Section 6.7.1](#)) every time the transceiver enters Active mode, if the TXD pin is clamped permanently LOW.

6.3.1.2 CAN Offline and Offline Bias modes

In CAN Offline mode, the transceiver monitors the CAN bus for a wake-up event. CANH and CANL are biased to GND.

CAN Offline Bias mode is the same as CAN Offline mode, with the exception that the CAN bus is biased to 2.5 V. This mode is activated automatically when activity is detected on the CAN bus while the transceiver is in CAN Offline mode. The transceiver will return to CAN Offline mode if the CAN bus is silent (no CAN bus edges) for longer than $t_{to(silence)}$.

The CAN transceiver switches to CAN Offline mode from CAN Active mode when:

- the UJA1162A switches to Standby or Sleep mode

provided the CAN-bus has been inactive for at least $t_{to(silence)}$. If the CAN-bus has been inactive for less than $t_{to(silence)}$, the CAN transceiver switches first to CAN Offline Bias mode and then to CAN Offline mode once the bus has been silent for $t_{to(silence)}$.

The CAN transceiver switches to CAN Offline Bias mode from CAN Active mode if:

- $V_{BUF} < V_{uvd(BUF)}$ OR $V_{IO} < V_{uvd(VIO)}$

The CAN transceiver switches to CAN Offline mode:

- from CAN Offline Bias mode when the UJA1162A is in Standby or Sleep mode and no activity has been detected on the bus (no CAN edges) for $t > t_{to(silence)}$ OR
- when the UJA1162A switches from Off or Overtemp mode to Standby mode

The CAN transceiver switches from CAN Offline mode to CAN Offline Bias mode if:

- a standard wake-up pattern is detected on the CAN bus OR
- the UJA1162A switches to Normal mode while $V_{BUF} < V_{uvd(BUF)}$ OR $V_{IO} < V_{uvd(VIO)}$

6.3.1.3 CAN Off mode

The CAN transceiver is switched off completely with the bus lines floating when:

- the UJA1162A switches to Off or Overtemp mode OR
- V_{BAT} falls below the CAN receiver undervoltage detection threshold, $V_{uvd(CAN)}$

It will be switched on again on entering CAN Offline mode when V_{BAT} rises above the undervoltage recovery threshold ($V_{uvr(CAN)}$) and the UJA1162A is no longer in Off/Overtemp mode. CAN Off mode prevents reverse currents flowing from the bus when the battery supply to the UJA1162A is lost.

6.3.2 CAN standard wake-up

The UJA1162A monitors the bus for a wake-up pattern when the CAN transceiver is in Offline mode.

A filter at the receiver input prevents unwanted wake-up events occurring due to automotive transients or EMI. A dominant-recessive-dominant wake-up pattern must be transmitted on the CAN bus within the wake-up timeout time ($t_{to(wake)}$) to pass the wake-up filter and trigger a wake-up event (see [Figure 4](#); note that additional pulses may occur between the recessive/dominant phases). The recessive and dominant phases must last at least $t_{wake(busrec)}$ and $t_{wake(busdom)}$, respectively.

Pin RXD is driven LOW when a valid CAN wake-up pattern is detected on the bus.

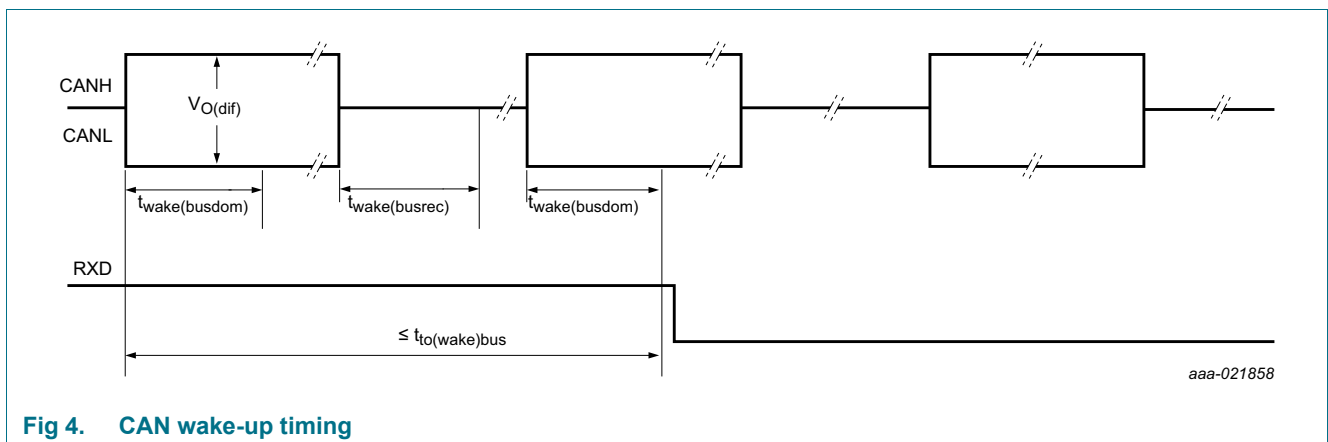

Fig 4. CAN wake-up timing

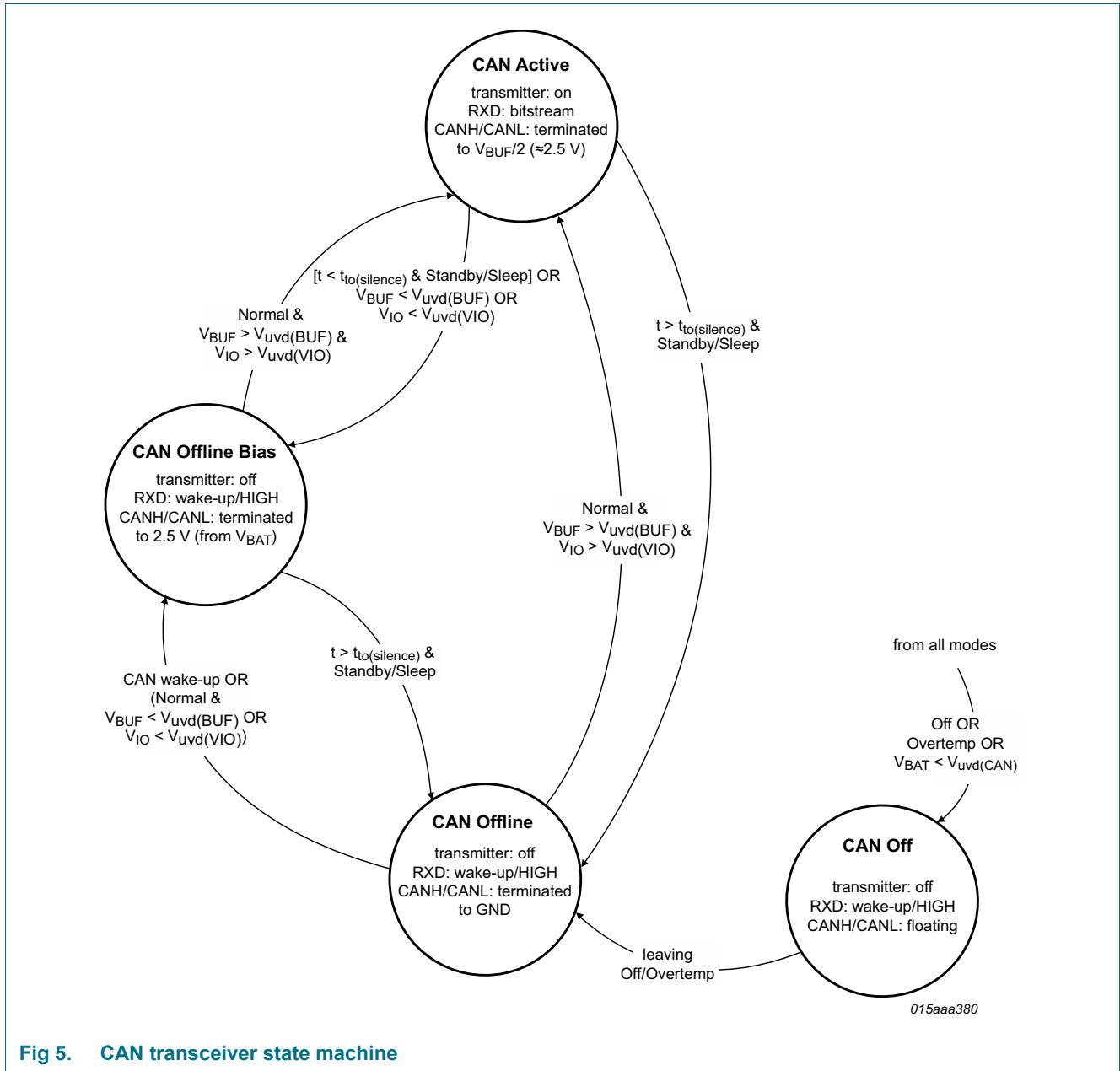

Fig 5. CAN transceiver state machine

6.4 WAKE pin

In Standby and Sleep modes, a local wake-up event is triggered by a LOW-to-HIGH or a HIGH-to-LOW transition on the WAKE pin. In applications that don't make use of the local wake-up facility, the WAKE pin should be connected to GND for optimal EMI performance.

Pin RXD is driven LOW when a valid edge is detected on pin WAKE.

6.5 VIO supply pin

Pin VIO should be connected to the microcontroller supply voltage. This will cause the signal levels on TXD, RXD, SLPN and CTS to be adjusted to the I/O levels of the microcontroller, enabling direct interfacing without the need for glue logic.

6.6 CAN transceiver status pin (CTS)

Pin CTS is driven HIGH to indicate to microcontroller that the transceiver is fully enabled and data can be transmitted and received via the TXD/RXD pins.

Pin CTS is actively driven LOW:

- while the transceiver is starting up (e.g. during a transition from Standby to Normal mode) or
- if pin TXD is clamped LOW for $t > t_{to(dom)TXD}$ or
- if an undervoltage is detected on VIO or BUF

6.7 CAN fail-safe features

6.7.1 TXD dominant timeout

A TXD dominant time-out timer is started when pin TXD is forced LOW while the transceiver is in CAN Active Mode. If the LOW state on pin TXD persists for longer than the TXD dominant time-out time ($t_{to(dom)TXD}$), the transmitter is disabled, releasing the bus lines to recessive state. This function prevents a hardware and/or software application failure from driving the bus lines to a permanent dominant state (blocking all network traffic). The TXD dominant time-out timer is reset when pin TXD goes HIGH. The TXD dominant time-out time also defines the minimum possible bit rate of 4.4 kbit/s.

6.7.2 Pull-up on TXD pin

Pin TXD has an internal pull-up (towards V_{IO}) to ensure a safe defined recessive driver state in case the pin is left floating.

6.7.3 Pull-down on SLPN pin

Pin SLPN has an internal pull-down (to GND) to ensure the UJA1162A switches to Sleep mode if SLPN is left floating.

6.7.4 Loss of power at pin BAT

A loss of power at pin BAT has no impact on the bus lines or on the microcontroller. No reverse currents flow from the bus.

7. Limiting values

Table 4. Limiting values

In accordance with the Absolute Maximum Rating System (IEC 60134).

| Symbol | Parameter | Conditions | Min | Max | Unit |
|--------------------------|---------------------------------------|---|------|------------------------|------|
| V _x | voltage on pin x ^[1] | pins BUF ^[2] , VIO | -0.2 | +6 | V |
| | | pins TXD, RXD, SLPN, CTS ^[3] | -0.2 | V _{BUF} + 0.2 | V |
| | | pins WAKE, INH | -18 | +40 | V |
| | | pin BAT | -0.2 | +40 | V |
| | | pins CANH and CANL with respect to any other pin | -58 | +58 | V |
| V _(CANH-CANL) | voltage between pin CANH and pin CANL | | -40 | +40 | V |
| V _{trt} | transient voltage | on pins CANL, CANH, WAKE, BAT ^[4] | | | |
| | | pulse 1 | -100 | - | V |
| | | pulse 2a | - | 75 | V |
| | | pulse 3a | -150 | - | V |
| | | pulse 3b | - | 100 | V |
| V _{ESD} | electrostatic discharge voltage | IEC 61000-4-2 (150 pF, 330 Ω) discharge circuit ^[5] | | | |
| | | on pins CANH and CANL; pin BAT with capacitor; pin WAKE with 10 nF capacitor and 10 kΩ resistor | -6 | +6 | kV |
| | | Human Body Model (HBM) | | | |
| | | on any pin ^[6] | -2 | +2 | kV |
| | | on pins BAT, WAKE ^[7] | -4 | +4 | kV |
| | | on pins CANH, CANL ^[8] | -8 | +8 | kV |
| | | Machine Model (MM) ^[9] | | | |
| | | on any pin | -100 | +100 | V |
| | | Charged Device Model (CDM) ^[10] | | | |
| | | on corner pins | -750 | +750 | V |
| on any other pin | -500 | +500 | V | | |
| T _{vj} | virtual junction temperature | ^[11] | -40 | +150 | °C |
| T _{stg} | storage temperature | | -55 | +150 | °C |

- [1] The device can sustain voltages up to the specified values over the product lifetime, provided applied voltages (including transients) never exceed these values.
- [2] When the device is not powered up, I_{BUF(max)} = 25 mA.
- [3] Maximum voltage should never exceed 6 V.
- [4] Verified by an external test house according to IEC TS 62228, Section 4.2.4; parameters for standard pulses defined in ISO7637 part 2.
- [5] Verified by an external test house according to IEC TS 62228, Section 4.3.
- [6] According to AEC-Q100-002.
- [7] Pins stressed to reference group containing all grounds, emulating the application circuit (Figure 9). HBM pulse as specified in AEC-Q100-002 used.
- [8] Pins stressed to reference group containing all ground and supply pins, emulating the application circuit (Figure 9). HBM pulse as specified in AEC-Q100-002 used.
- [9] According to AEC-Q100-003.
- [10] According to AEC-Q100-011.

[11] In accordance with IEC 60747-1. An alternative definition of virtual junction temperature is: $T_{vj} = T_{amb} + P \times R_{th(j-a)}$, where $R_{th(j-a)}$ is a fixed value used in the calculation of T_{vj} . The rating for T_{vj} limits the allowable combinations of power dissipation (P) and ambient temperature (T_{amb}).

8. Thermal characteristics

Table 5. Thermal characteristics

| Symbol | Parameter | Conditions | Typ | Unit |
|----------------|---|------------|-----|------|
| $R_{th(vj-a)}$ | thermal resistance from virtual junction to ambient | | 60 | K/W |

[1] According to JEDEC JESD51-2, JESD51-5 and JESD51-7 at natural convection on 2s2p board. Board with two inner copper layers (thickness: 35 μm) and thermal via array under the exposed pad connected to the first inner copper layer (thickness: 70 μm).

9. Static characteristics

Table 6. Static characteristics

$T_{vj} = -40\text{ }^{\circ}\text{C}$ to $+150\text{ }^{\circ}\text{C}$; $V_{BAT} = 4.5\text{ V}$ to 28 V ; $V_{IO} = 2.85\text{ V}$ to 5.5 V ; $R_L = R_{(CANH-CANL)} = 60\ \Omega$; all voltages are defined with respect to ground; positive currents flow into the IC; typical values are given at $V_{BAT} = 13\text{ V}$; unless otherwise specified.

| Symbol | Parameter | Conditions | Min | Typ | Max | Unit |
|---|--|--|--------------|-----|---------------|---------------|
| Supply; pin BAT | | | | | | |
| $V_{th(det)pon}$ | power-on detection threshold voltage | V_{BAT} rising | 4.2 | - | 4.55 | V |
| $V_{th(det)poff}$ | power-off detection threshold voltage | V_{BAT} falling | 2.8 | - | 3 | V |
| $V_{uvr(CAN)}$ | CAN undervoltage recovery voltage | V_{BAT} rising | 4.5 | - | 5 | V |
| $V_{uvd(CAN)}$ | CAN undervoltage detection voltage | V_{BAT} falling | 4.2 | - | 4.55 | V |
| I_{BAT} | battery supply current | Normal mode; CAN Active mode | | | | |
| | | CAN recessive; $V_{TXD} = V_{IO}$ | - | 4 | 7.5 | mA |
| | | CAN dominant; $V_{TXD} = 0\text{ V}$ | - | 46 | 67 | mA |
| | | Sleep mode; CAN Offline mode; $-40\text{ }^{\circ}\text{C} < T_{vj} < +85\text{ }^{\circ}\text{C}$; $V_{BAT} = 7\text{ V}$ to 18 V | - | 2 | 65 | μA |
| | | Standby mode; CAN Offline mode; $-40\text{ }^{\circ}\text{C} < T_{vj} < +85\text{ }^{\circ}\text{C}$; $V_{BAT} = 7\text{ V}$ to 18 V | - | 2 | 91 | μA |
| | additional current in CAN Offline Bias mode; $-40\text{ }^{\circ}\text{C} < T_{vj} < 85\text{ }^{\circ}\text{C}$ | - | 38 | 55 | μA | |
| Voltage source; pin BUF | | | | | | |
| V_O | output voltage | $V_{BAT} = 5.5\text{ V}$ to 28 V | 4.9 | 5 | 5.1 | V |
| V_{uvd} | undervoltage detection voltage | | 4.5 | - | 4.75 | V |
| $I_{O(sc)}$ | short-circuit output current | | -300 | - | -150 | mA |
| Supply; pin VIO | | | | | | |
| V_{uvd} | undervoltage detection voltage | | 2.7 | - | 2.85 | V |
| $I_{I(VIO)}$ | input current on pin VIO | Standby/Normal mode; $-40\text{ }^{\circ}\text{C} < T_{vj} < 85\text{ }^{\circ}\text{C}$ | - | 7.1 | 11 | μA |
| | | Sleep mode; $-40\text{ }^{\circ}\text{C} < T_{vj} < 85\text{ }^{\circ}\text{C}$ | - | 5.9 | 9.5 | μA |
| Sleep mode control input; pin SLPN | | | | | | |
| $V_{th(sw)}$ | switching threshold voltage | | $0.25V_{IO}$ | - | $0.75V_{IO}$ | V |

Table 6. Static characteristics ...continued

$T_{vj} = -40\text{ °C to }+150\text{ °C}$; $V_{BAT} = 4.5\text{ V to }28\text{ V}$; $V_{IO} = 2.85\text{ V to }5.5\text{ V}$; $R_L = R_{(CANH-CANL)} = 60\text{ }\Omega$; all voltages are defined with respect to ground; positive currents flow into the IC; typical values are given at $V_{BAT} = 13\text{ V}$; unless otherwise specified. [1]

| Symbol | Parameter | Conditions | Min | Typ | Max | Unit |
|---|--|---|-----------------|-----|--------------|---------------|
| R_{pd} | pull-down resistance | | 40 | 60 | 80 | k Ω |
| Inhibit output: pin INH | | | | | | |
| V_O | output voltage | $I_{INH} = -180\text{ }\mu\text{A}$ | $V_{BAT} - 0.8$ | - | V_{BAT} | V |
| R_{pd} | pull-down resistance | Sleep mode | 3 | 4 | 5 | M Ω |
| CAN transmit data input; pin TXD | | | | | | |
| $V_{th(sw)}$ | switching threshold voltage | | $0.25V_{IO}$ | - | $0.75V_{IO}$ | V |
| $V_{th(sw)hys}$ | switching threshold voltage hysteresis | | $0.05V_{BUF}$ | - | - | V |
| R_{pu} | pull-up resistance | | 40 | 60 | 80 | k Ω |
| CAN transmitter status; pin CTS | | | | | | |
| I_{OH} | HIGH-level output current | $V_{CTS} = V_{IO} - 0.4\text{ V}$; transmitter on | - | - | -4 | mA |
| I_{OL} | LOW-level output current | $V_{CTS} = 0.4\text{ V}$; transmitter off | 4 | - | - | mA |
| CAN receive data output; pin RXD | | | | | | |
| V_{OH} | HIGH-level output voltage | $I_{OH} = -4\text{ mA}$ | $V_{IO} - 0.4$ | - | - | V |
| V_{OL} | LOW-level output voltage | $I_{OL} = 4\text{ mA}$ | - | - | 0.4 | V |
| R_{pu} | pull-up resistance | CAN Offline mode | 40 | 60 | 80 | k Ω |
| Local wake input; pin WAKE | | | | | | |
| $V_{th(sw)r}$ | rising switching threshold voltage | | 2.8 | - | 4.1 | V |
| $V_{th(sw)f}$ | falling switching threshold voltage | | 2.4 | - | 3.75 | V |
| $V_{hys(i)}$ | input hysteresis voltage | | 250 | - | 800 | mV |
| I_i | input current | $T_{vj} = -40\text{ °C to }+85\text{ °C}$ | - | - | 1.5 | μA |
| High-speed CAN bus lines; pins CANH and CANL | | | | | | |
| $V_{O(dom)}$ | dominant output voltage | CAN Active mode; $V_{TXD} = 0\text{ V}$; $V_{BAT} > 5.5\text{ V}$; $t < t_{to(dom)TXD}$ | | | | |
| | | pin CANH; $R_L = 50\text{ }\Omega\text{ to }65\text{ }\Omega$ | 2.75 | 3.5 | 4.5 | V |
| | | pin CANL; $R_L = 50\text{ }\Omega\text{ to }65\text{ }\Omega$ | 0.5 | 1.5 | 2.25 | V |
| $V_{dom(TX)sym}$ | transmitter dominant voltage symmetry | $V_{dom(TX)sym} = V_{BUF} - V_{CANH} - V_{CANL}$; $V_{BAT} > 5.5\text{ V}$ | -400 | - | +400 | mV |
| V_{TXsym} | transmitter voltage symmetry | $V_{TXsym} = V_{CANH} + V_{CANL}$; [3] $f_{TXD} = 250\text{ kHz, }1\text{ MHz or }.5\text{ MHz}$; [4] $C_{SPLIT} = 4.7\text{ nF}$ | $0.9V_{BUF}$ | - | $1.1V_{BUF}$ | V |

Table 6. Static characteristics ...continued

$T_{vj} = -40\text{ }^{\circ}\text{C}$ to $+150\text{ }^{\circ}\text{C}$; $V_{BAT} = 4.5\text{ V}$ to 28 V ; $V_{IO} = 2.85\text{ V}$ to 5.5 V ; $R_L = R_{(CANH-CANL)} = 60\text{ }\Omega$; all voltages are defined with respect to ground; positive currents flow into the IC; typical values are given at $V_{BAT} = 13\text{ V}$; unless otherwise specified.^[1]

| Symbol | Parameter | Conditions | Min | Typ | Max | Unit |
|------------------|--|--|-------------------|--------------|--------------------|------------|
| $V_{O(dif)}$ | differential output voltage | CAN Active mode (dominant); $V_{TXD} = 0\text{ V}$; $V_{BAT} > 5.5\text{ V}$; $t < t_{to(dom)TXD}$ | | | | |
| | | $R_L = 50\text{ }\Omega$ to $65\text{ }\Omega$ | 1.5 | - | 3 | V |
| | | $R_L = 45\text{ }\Omega$ to $70\text{ }\Omega$ | 1.4 | - | 3.3 | V |
| | | $R_L = 2240\text{ }\Omega$ | 1.5 | - | 5 | V |
| | | recessive; $R_L = \text{no load}$; $V_{BAT} > 5.5\text{ V}$ | | | | |
| | | CAN Active/Offline Bias mode; $V_{TXD} = V_{IO}$ | -50 | - | +50 | mV |
| | CAN Offline mode | -0.2 | - | +0.2 | V | |
| $V_{O(rec)}$ | recessive output voltage | CAN Active mode; $V_{TXD} = V_{IO}$; $V_{BAT} > 5.5\text{ V}$; $R_L = \text{no load}$ | 2 | $0.5V_{BUF}$ | 3 | V |
| | | CAN Offline mode; $V_{BAT} > 5.5\text{ V}$; $R_L = \text{no load}$ | -0.1 | - | +0.1 | V |
| | | CAN Offline Bias mode; $R_L = \text{no load}$ | 2 | 2.5 | 3 | V |
| $I_{O(sc)dom}$ | dominant short-circuit output current | CAN Active mode; $V_{BAT} > 5.5\text{ V}$; $V_{TXD} = 0\text{ V}$ | | | | |
| | | pin CANH; $V_{CANH} = -3\text{ V}$ to $+27\text{ V}$ | -55 | - | - | mA |
| | | pin CANL; $V_{CANL} = -15\text{ V}$ to $+18\text{ V}$ | - | - | +55 | mA |
| $I_{O(sc)rec}$ | recessive short-circuit output current | $V_{CANL} = V_{CANH} = -27\text{ V}$ to $+32\text{ V}$; $V_{TXD} = V_{IO}$ | -3 | - | +3 | mA |
| $V_{th(RX)dif}$ | differential receiver threshold voltage | $-12\text{ V} \leq V_{CANL} \leq +12\text{ V}$; $-12\text{ V} \leq V_{CANH} \leq +12\text{ V}$ | | | | |
| | | CAN Active mode | 0.5 | 0.7 | 0.9 | V |
| | | CAN Offline mode | 0.4 | 0.7 | 1.15 | V |
| $V_{rec(RX)}$ | receiver recessive voltage | $-12\text{ V} \leq V_{CANL} \leq +12\text{ V}$; $-12\text{ V} \leq V_{CANH} \leq +12\text{ V}$ | | | | |
| | | CAN Active mode | -4 ^[3] | - | +0.5 | V |
| | | CAN Offline/Offline Bias modes | -4 ^[3] | - | +0.4 | V |
| $V_{dom(RX)}$ | receiver dominant voltage | $-12\text{ V} \leq V_{CANL} \leq +12\text{ V}$; $-12\text{ V} \leq V_{CANH} \leq +12\text{ V}$ | | | | |
| | | CAN Active mode | 0.9 | - | 9.0 ^[3] | V |
| | | CAN Offline/Offline Bias modes | 1.15 | - | 9.0 ^[3] | V |
| $V_{hys(RX)dif}$ | differential receiver hysteresis voltage | CAN Active mode; $-12\text{ V} \leq V_{CANL} \leq +12\text{ V}$; $-12\text{ V} \leq V_{CANH} \leq +12\text{ V}$ | 1 | 30 | 60 | mV |
| R_i | input resistance | $-2\text{ V} \leq V_{CANL} \leq +7\text{ V}$; $-2\text{ V} \leq V_{CANH} \leq +7\text{ V}$ | 9 | 15 | 28 | k Ω |

Table 6. Static characteristics ...continued

$T_{vj} = -40\text{ }^{\circ}\text{C}$ to $+150\text{ }^{\circ}\text{C}$; $V_{BAT} = 4.5\text{ V}$ to 28 V ; $V_{IO} = 2.85\text{ V}$ to 5.5 V ; $R_L = R_{(CANH-CANL)} = 60\ \Omega$; all voltages are defined with respect to ground; positive currents flow into the IC; typical values are given at $V_{BAT} = 13\text{ V}$; unless otherwise specified.^[1]

| Symbol | Parameter | Conditions | Min | Typ | Max | Unit |
|-------------------------------|---|---|-----|-----|-----|--------------------|
| ΔR_i | input resistance deviation | $0\text{ V} \leq V_{CANL} \leq +5\text{ V}$; $0\text{ V} \leq V_{CANH} \leq +5\text{ V}$ | -1 | - | +1 | % |
| $R_{i(dif)}$ | differential input resistance | $-2\text{ V} \leq V_{CANL} \leq +7\text{ V}$; $-2\text{ V} \leq V_{CANH} \leq +7\text{ V}$ | 19 | 30 | 52 | k Ω |
| $C_{i(cm)}$ | common-mode input capacitance | | [3] | - | 20 | pF |
| $C_{i(dif)}$ | differential input capacitance | | [3] | - | 10 | pF |
| I_L | leakage current | $V_{BAT} = V_{BUF} = 0\text{ V}$ or $V_{BAT} = V_{BUF} = \text{shorted to ground}$ via $47\text{ k}\Omega$; $V_{CANH} = V_{CANL} = 5\text{ V}$ | -5 | - | +5 | μA |
| Temperature protection | | | | | | |
| $T_{th(act)otp}$ | overtemperature protection activation threshold temperature | | 167 | 177 | 187 | $^{\circ}\text{C}$ |
| $T_{th(rel)otp}$ | overtemperature protection release threshold temperature | | 127 | 137 | 147 | $^{\circ}\text{C}$ |

- [1] All parameters are guaranteed over the virtual junction temperature range by design. Factory testing uses correlated test conditions to cover the specified temperature and power supply voltage range.
- [2] See [Figure 6](#).
- [3] Not tested in production; guaranteed by design.
- [4] The test circuit used to measure the bus output voltage symmetry (which includes C_{SPLIT}) is shown in [Figure 11](#).

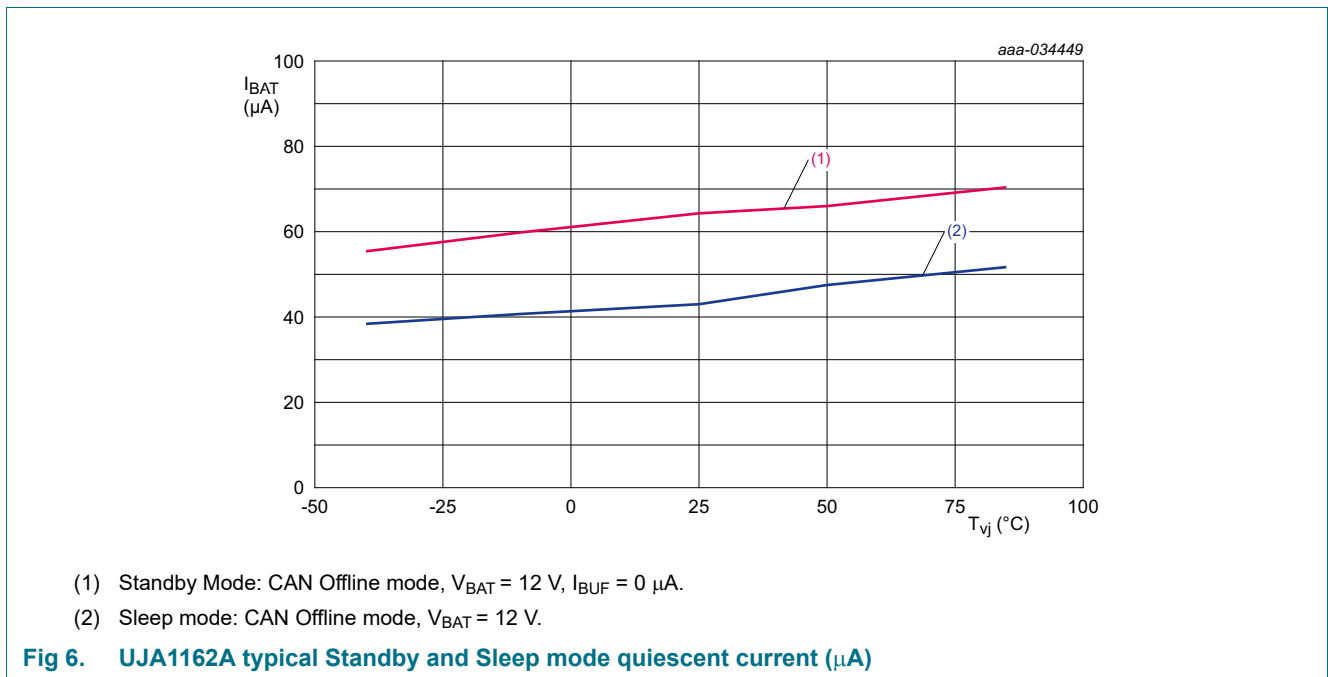

10. Dynamic characteristics

Table 7. Dynamic characteristics

$T_{vj} = -40\text{ }^{\circ}\text{C}$ to $+150\text{ }^{\circ}\text{C}$; $V_{BAT} = 4.5\text{ V}$ to 28 V ; $V_{IO} = 2.85\text{ V}$ to 5.5 V ; $R_L = R_{(CANH-CANL)} = 60\text{ }\Omega$; $C_{(CANH-CANL)} = 100\text{ pF}$; all voltages are defined with respect to ground; positive currents flow into the IC; typical values are given at $V_{BAT} = 13\text{ V}$; unless otherwise specified.^[1]

| Symbol | Parameter | Conditions | Min | Typ | Max | Unit |
|---|--|---|-----|-----|------|---------------|
| Voltage sources; pins BUF and VIO | | | | | | |
| t_{startup} | start-up time | from V_{BAT} exceeding the power-on detection threshold until $V_{BUF} > 90\%$ undervoltage threshold; $C_{BUF} = 4.7\text{ }\mu\text{F}$ | - | 2.8 | 4.7 | ms |
| $t_{d(\text{uvd})}$ | undervoltage detection delay time | | 6 | - | 54 | μs |
| $t_{d(\text{uvd-sleep})}$ | delay time from undervoltage detection to sleep mode | from undervoltage detection on VIO until UJA1162A forced to Sleep mode | 180 | - | 440 | ms |
| Mode control: pin SLPN | | | | | | |
| $t_{\text{ftr}(\text{sleep})}$ | sleep filter time | | 2.5 | - | 13.5 | μs |
| $t_{d(\text{sleep})}$ | sleep delay time | minimum LOW time to trigger a transition to Sleep mode | 21 | - | 36 | μs |
| Pin WAKE | | | | | | |
| $t_{\text{det}(\text{wake})}$ | wake-up detection time | | 7 | - | 42 | μs |
| CAN transceiver timing; pins CANH, CANL, TXD and RXD | | | | | | |
| $t_{d(\text{TXD-busdom})}$ | delay time from TXD to bus dominant | | [2] | - | 80 | - ns |
| $t_{d(\text{TXD-busrec})}$ | delay time from TXD to bus recessive | | [2] | - | 80 | - ns |
| $t_{d(\text{busdom-RXD})}$ | delay time from bus dominant to RXD | | [2] | - | 105 | - ns |
| $t_{d(\text{busrec-RXD})}$ | delay time from bus recessive to RXD | | [2] | - | 120 | - ns |
| $t_{d(\text{TXDL-RXDL})}$ | delay time from TXD LOW to RXD LOW | $t_{\text{bit}(\text{TXD})} = 200\text{ ns}$ | [3] | - | - | 255 ns |
| $t_{d(\text{TXDH-RXDH})}$ | delay time from TXD HIGH to RXD HIGH | $t_{\text{bit}(\text{TXD})} = 200\text{ ns}$ | - | - | - | 255 ns |
| $t_{\text{bit}(\text{bus})}$ | transmitted recessive bit width | $t_{\text{bit}(\text{TXD})} = 500\text{ ns}$ | [3] | 435 | - | 530 ns |
| | | $t_{\text{bit}(\text{TXD})} = 200\text{ ns}$ | [3] | 155 | - | 210 ns |
| $t_{\text{bit}(\text{RXD})}$ | bit time on pin RXD | $t_{\text{bit}(\text{TXD})} = 500\text{ ns}$ | [3] | 400 | - | 550 ns |
| | | $t_{\text{bit}(\text{TXD})} = 200\text{ ns}$ | [3] | 120 | - | 220 ns |
| Δt_{rec} | receiver timing symmetry | $t_{\text{bit}(\text{TXD})} = 500\text{ ns}$ | - | -65 | - | +40 ns |
| | | $t_{\text{bit}(\text{TXD})} = 200\text{ ns}$ | - | -45 | - | +15 ns |
| $t_{\text{wake}(\text{busdom})}$ | bus dominant wake-up time | first pulse (after first recessive) for wake-up on pins CANH and CANL; CAN Offline mode | 0.5 | - | 1.8 | μs |
| | | second pulse for wake-up on pins CANH and CANL | 0.5 | - | 1.8 | μs |
| $t_{\text{wake}(\text{busrec})}$ | bus recessive wake-up time | first pulse for wake-up on pins CANH and CANL; CAN Offline mode | 0.5 | - | 1.8 | μs |
| | | second pulse (after first dominant) for wake-up on pins CANH and CANL | 0.5 | - | 1.8 | μs |
| $t_{\text{to}(\text{wake})\text{bus}}$ | bus wake-up time-out time | between first and second dominant pulses; CAN Offline mode | 0.8 | - | 10 | ms |
| $t_{\text{to}(\text{dom})\text{TXD}}$ | TXD dominant time-out time | CAN Active mode; $V_{\text{TXD}} = 0\text{ V}$ | 2.7 | - | 3.3 | ms |

Table 7. Dynamic characteristics ...continued

$T_{vj} = -40\text{ }^{\circ}\text{C}$ to $+150\text{ }^{\circ}\text{C}$; $V_{BAT} = 4.5\text{ V}$ to 28 V ; $V_{IO} = 2.85\text{ V}$ to 5.5 V ; $R_L = R_{(CANH-CANL)} = 60\ \Omega$; $C_{(CANH-CANL)} = 100\text{ pF}$; all voltages are defined with respect to ground; positive currents flow into the IC; typical values are given at $V_{BAT} = 13\text{ V}$; unless otherwise specified.^[1]

| Symbol | Parameter | Conditions | Min | Typ | Max | Unit |
|------------------------|------------------------------------|---|------|-----|------|---------------|
| $t_{to(silence)}$ | bus silence time-out time | recessive time measurement started in all CAN modes | 0.95 | - | 1.17 | s |
| $t_{d(busact-bias)}$ | delay time from bus active to bias | | - | - | 200 | μs |
| $t_{startup(CAN)}$ | CAN start-up time | when switching to Active mode (CTS = HIGH) | - | - | 220 | μs |
| Mode transition | | | | | | |
| $t_{d(act)norm}$ | normal mode activation delay time | delay before CAN transceiver is activated after the UJA1162A enters Normal mode | - | - | 320 | μs |

- [1] All parameters are guaranteed over the virtual junction temperature range by design. Factory testing uses correlated test conditions to cover the specified temperature and power supply voltage range.
- [2] See [Figure 7](#) and [Figure 10](#).
- [3] See [Figure 8](#) and [Figure 10](#).

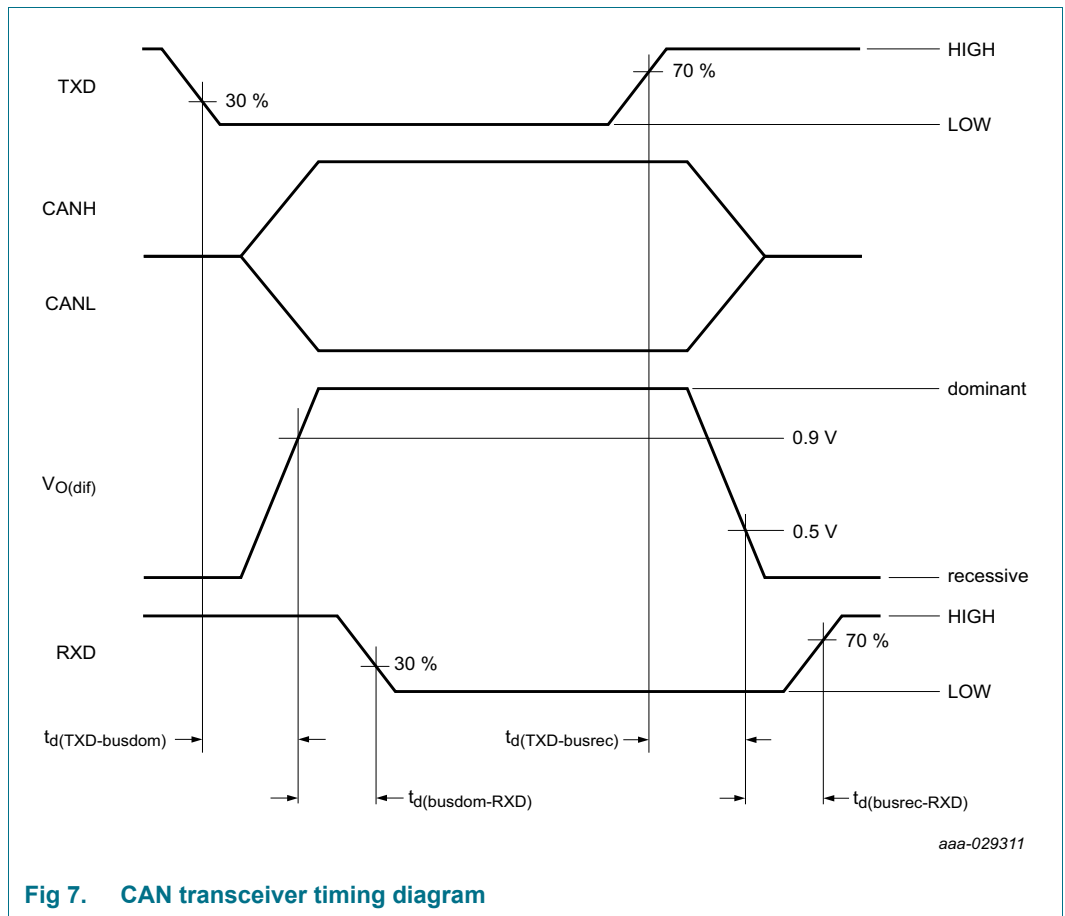

Fig 7. CAN transceiver timing diagram

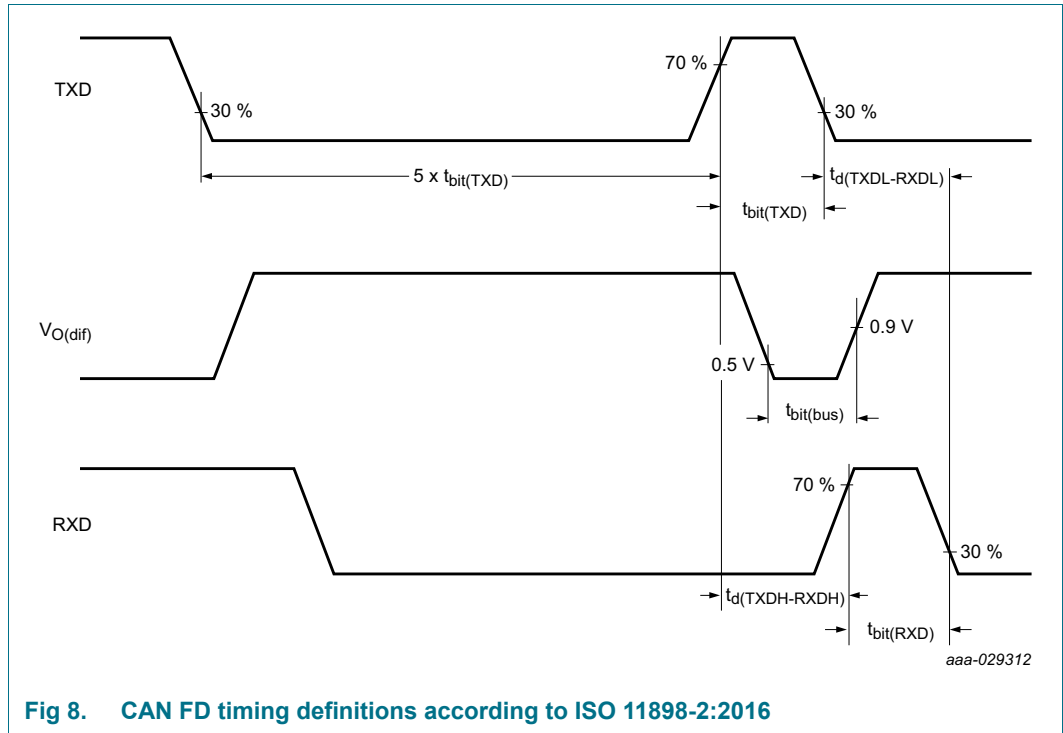

Fig 8. CAN FD timing definitions according to ISO 11898-2:2016

11. Application information

11.1 Application diagram

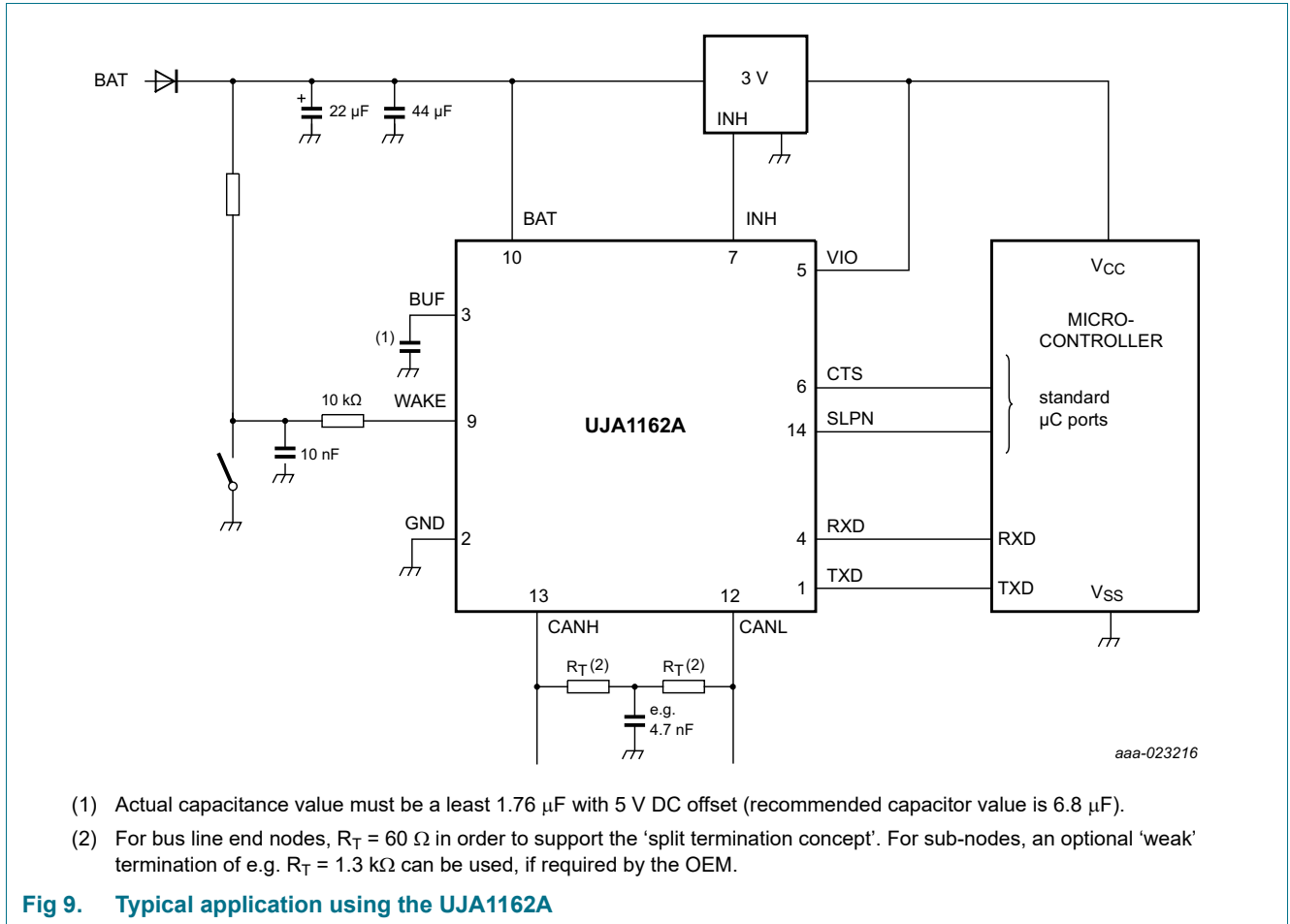

Fig 9. Typical application using the UJA1162A

12. Test information

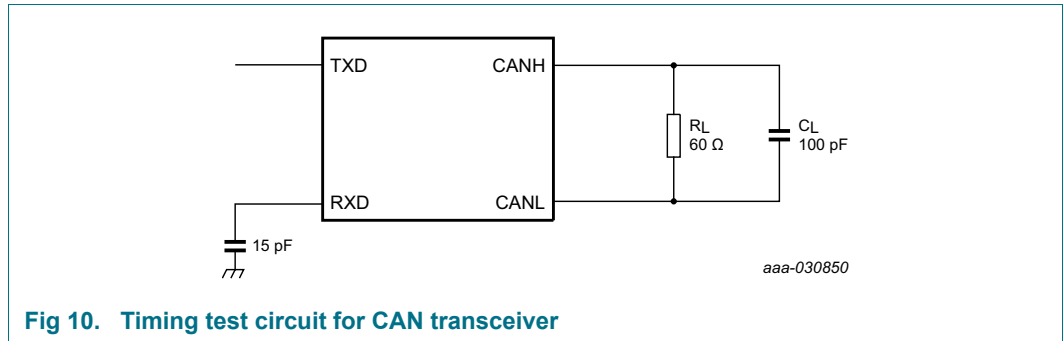

Fig 10. Timing test circuit for CAN transceiver

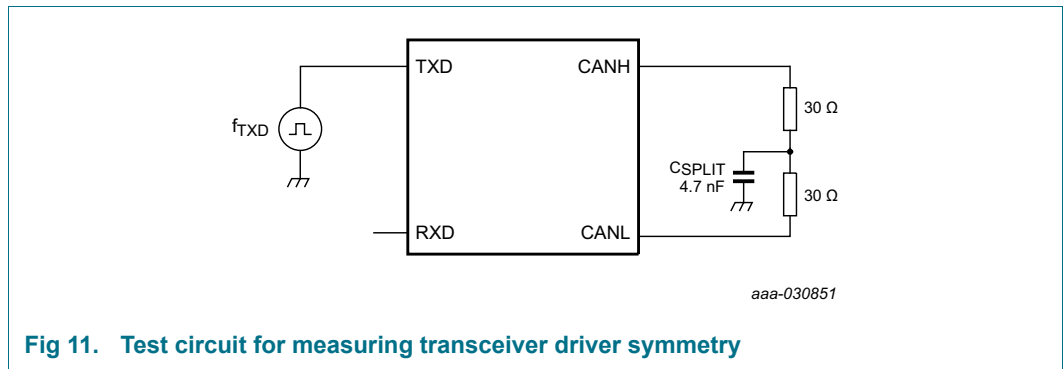

Fig 11. Test circuit for measuring transceiver driver symmetry

12.1 Quality information

This product has been qualified in accordance with the Automotive Electronics Council (AEC) standard Q100 Rev-G - *Failure mechanism based stress test qualification for integrated circuits*, and is suitable for use in automotive applications.

13. Package outline

HVSON14: plastic, thermal enhanced very thin small outline package; no leads; 14 terminals; body 3 x 4.5 x 0.85 mm

SOT1086-2

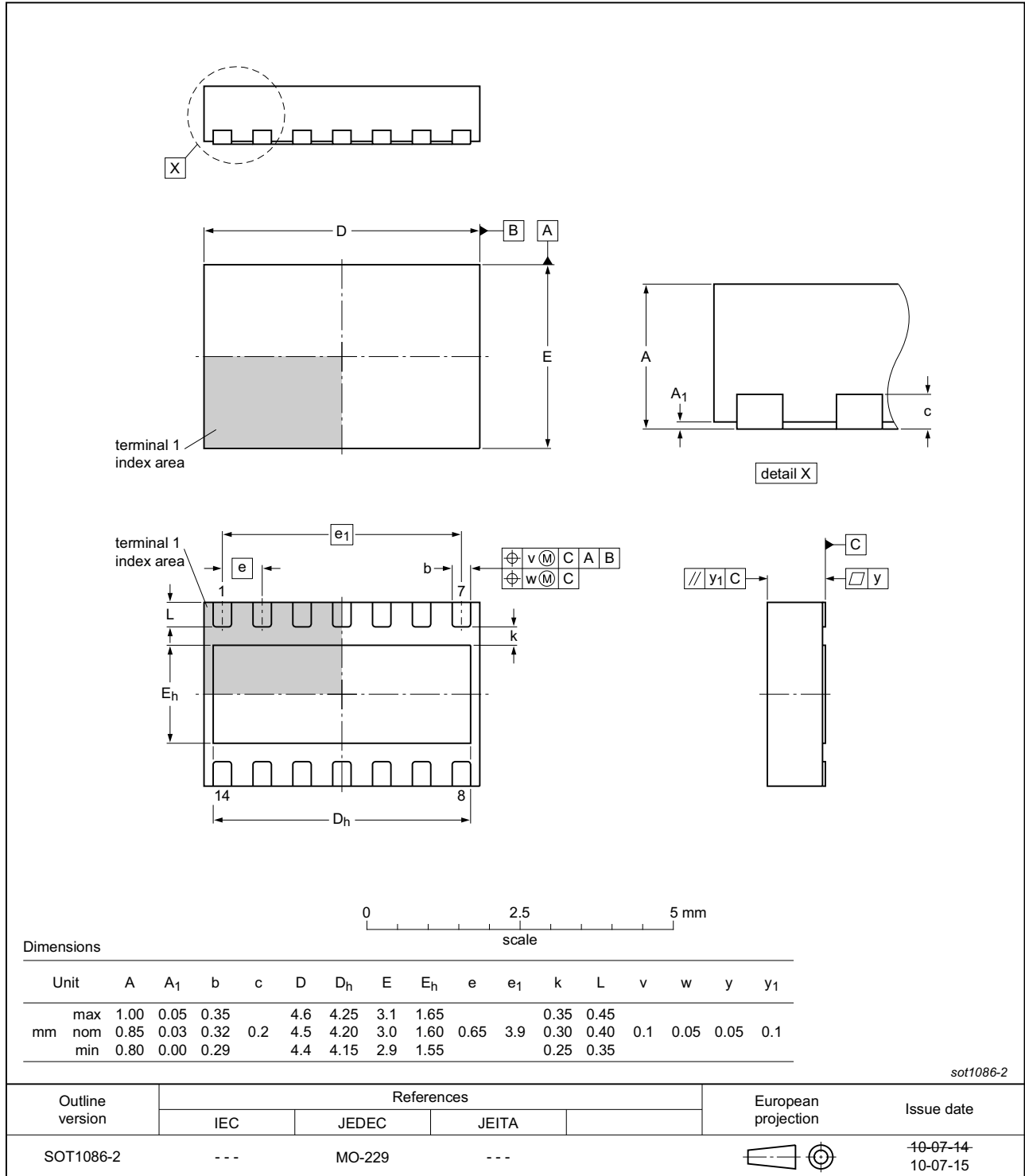

Fig 12. Package outline SOT1086-2 (HVSON14)

14. Handling information

All input and output pins are protected against ElectroStatic Discharge (ESD) under normal handling. When handling ensure that the appropriate precautions are taken as described in *JESD625-A* or equivalent standards.

15. Soldering of SMD packages

This text provides a very brief insight into a complex technology. A more in-depth account of soldering ICs can be found in Application Note *AN10365 "Surface mount reflow soldering description"*.

15.1 Introduction to soldering

Soldering is one of the most common methods through which packages are attached to Printed Circuit Boards (PCBs), to form electrical circuits. The soldered joint provides both the mechanical and the electrical connection. There is no single soldering method that is ideal for all IC packages. Wave soldering is often preferred when through-hole and Surface Mount Devices (SMDs) are mixed on one printed wiring board; however, it is not suitable for fine pitch SMDs. Reflow soldering is ideal for the small pitches and high densities that come with increased miniaturization.

15.2 Wave and reflow soldering

Wave soldering is a joining technology in which the joints are made by solder coming from a standing wave of liquid solder. The wave soldering process is suitable for the following:

- Through-hole components
- Leaded or leadless SMDs, which are glued to the surface of the printed circuit board

Not all SMDs can be wave soldered. Packages with solder balls, and some leadless packages which have solder lands underneath the body, cannot be wave soldered. Also, leaded SMDs with leads having a pitch smaller than ~0.6 mm cannot be wave soldered, due to an increased probability of bridging.

The reflow soldering process involves applying solder paste to a board, followed by component placement and exposure to a temperature profile. Leaded packages, packages with solder balls, and leadless packages are all reflow solderable.

Key characteristics in both wave and reflow soldering are:

- Board specifications, including the board finish, solder masks and vias
- Package footprints, including solder thieves and orientation
- The moisture sensitivity level of the packages
- Package placement
- Inspection and repair
- Lead-free soldering versus SnPb soldering

15.3 Wave soldering

Key characteristics in wave soldering are:

- Process issues, such as application of adhesive and flux, clinching of leads, board transport, the solder wave parameters, and the time during which components are exposed to the wave
- Solder bath specifications, including temperature and impurities

15.4 Reflow soldering

Key characteristics in reflow soldering are:

- Lead-free versus SnPb soldering; note that a lead-free reflow process usually leads to higher minimum peak temperatures (see [Figure 13](#)) than a SnPb process, thus reducing the process window
- Solder paste printing issues including smearing, release, and adjusting the process window for a mix of large and small components on one board
- Reflow temperature profile; this profile includes preheat, reflow (in which the board is heated to the peak temperature) and cooling down. It is imperative that the peak temperature is high enough for the solder to make reliable solder joints (a solder paste characteristic). In addition, the peak temperature must be low enough that the packages and/or boards are not damaged. The peak temperature of the package depends on package thickness and volume and is classified in accordance with [Table 8](#) and [9](#)

Table 8. SnPb eutectic process (from J-STD-020D)

| Package thickness (mm) | Package reflow temperature (°C) | |
|------------------------|---------------------------------|-------|
| | Volume (mm ³) | |
| | < 350 | ≥ 350 |
| < 2.5 | 235 | 220 |
| ≥ 2.5 | 220 | 220 |

Table 9. Lead-free process (from J-STD-020D)

| Package thickness (mm) | Package reflow temperature (°C) | | |
|------------------------|---------------------------------|-------------|--------|
| | Volume (mm ³) | | |
| | < 350 | 350 to 2000 | > 2000 |
| < 1.6 | 260 | 260 | 260 |
| 1.6 to 2.5 | 260 | 250 | 245 |
| > 2.5 | 250 | 245 | 245 |

Moisture sensitivity precautions, as indicated on the packing, must be respected at all times.

Studies have shown that small packages reach higher temperatures during reflow soldering, see [Figure 13](#).

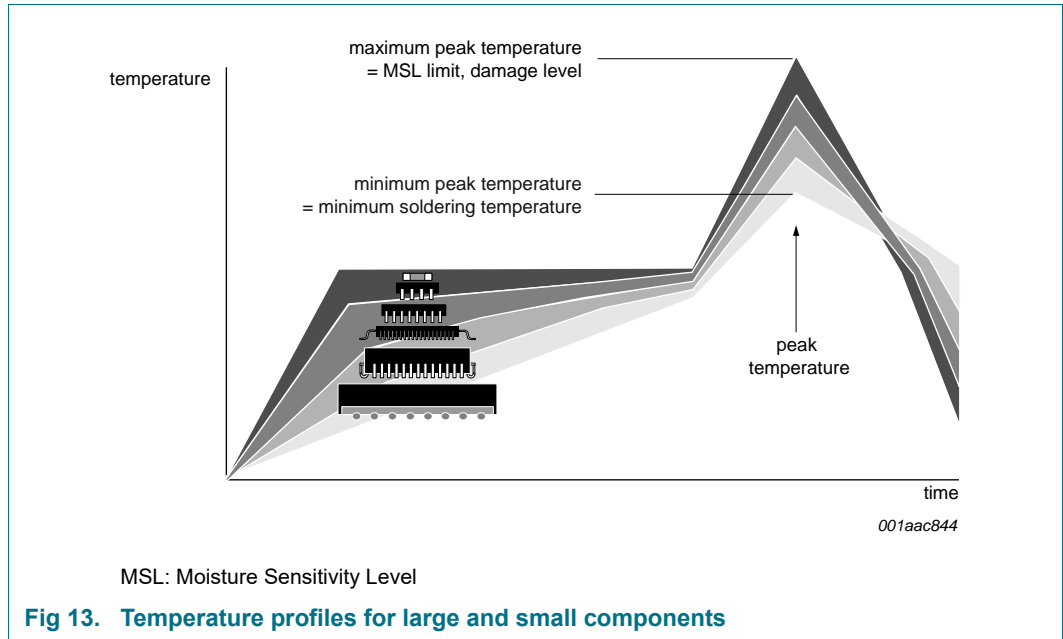

For further information on temperature profiles, refer to Application Note *AN10365* “*Surface mount reflow soldering description*”.

16. Soldering of HVSON packages

[Section 15](#) contains a brief introduction to the techniques most commonly used to solder Surface Mounted Devices (SMD). A more detailed discussion on soldering HVSON leadless package ICs can found in the following application notes:

- *AN10365* “*Surface mount reflow soldering description*”
- *AN10366* “*HVQFN application information*”

17. Appendix: ISO 11898-2:201x parameter cross-reference list

Table 10. ISO 11898-2:201x to NXP data sheet parameter conversion

| ISO 11898-2:201x | | NXP data sheet | |
|--|------------------------------|--------------------|---|
| Parameter | Notation | Symbol | Parameter |
| HS-PMA dominant output characteristics | | | |
| Single ended voltage on CAN_H | V_{CAN_H} | $V_{O(dom)}$ | dominant output voltage |
| Single ended voltage on CAN_L | V_{CAN_L} | | |
| Differential voltage on normal bus load | V_{Diff} | $V_{O(dif)}$ | differential output voltage |
| Differential voltage on effective resistance during arbitration | | | |
| Optional: Differential voltage on extended bus load range | | | |
| HS-PMA driver symmetry | | | |
| Driver symmetry | V_{SYM} | V_{TXsym} | transmitter voltage symmetry |
| Maximum HS-PMA driver output current | | | |
| Absolute current on CAN_H | I_{CAN_H} | $I_{O(sc)dom}$ | dominant short-circuit output current |
| Absolute current on CAN_L | I_{CAN_L} | | |
| HS-PMA recessive output characteristics, bus biasing active/inactive | | | |
| Single ended output voltage on CAN_H | V_{CAN_H} | $V_{O(rec)}$ | recessive output voltage |
| Single ended output voltage on CAN_L | V_{CAN_L} | | |
| Differential output voltage | V_{Diff} | $V_{O(dif)}$ | differential output voltage |
| Optional HS-PMA transmit dominant timeout | | | |
| Transmit dominant timeout, long | t_{dom} | $t_{to(dom)TXD}$ | TXD dominant time-out time |
| Transmit dominant timeout, short | | | |
| HS-PMA static receiver input characteristics, bus biasing active/inactive | | | |
| Recessive state differential input voltage range | V_{Diff} | $V_{th(RX)dif}$ | differential receiver threshold voltage |
| Dominant state differential input voltage range | | $V_{rec(RX)}$ | receiver recessive voltage |
| | | $V_{dom(RX)}$ | receiver dominant voltage |
| HS-PMA receiver input resistance (matching) | | | |
| Differential internal resistance | R_{Diff} | $R_{i(dif)}$ | differential input resistance |
| Single ended internal resistance | R_{CAN_H} R_{CAN_L} | R_i | input resistance |
| Matching of internal resistance | MR | ΔR_i | input resistance deviation |
| HS-PMA implementation loop delay requirement | | | |
| Loop delay | t_{Loop} | $t_{d(TXDH-RXDH)}$ | delay time from TXD HIGH to RXD HIGH |
| | | $t_{d(TXDL-RXDL)}$ | delay time from TXD LOW to RXD LOW |
| Optional HS-PMA implementation data signal timing requirements for use with bit rates above 1 Mbit/s up to 2 Mbit/s and above 2 Mbit/s up to 5 Mbit/s | | | |
| Transmitted recessive bit width @ 2 Mbit/s / @ 5 Mbit/s, intended | $t_{Bit(Bus)}$ | $t_{bit(bus)}$ | transmitted recessive bit width |
| Received recessive bit width @ 2 Mbit/s / @ 5 Mbit/s | $t_{Bit(RXD)}$ | $t_{bit(RXD)}$ | bit time on pin RXD |
| Receiver timing symmetry @ 2 Mbit/s / @ 5 Mbit/s | Δt_{Rec} | Δt_{rec} | receiver timing symmetry |

Table 10. ISO 11898-2:201x to NXP data sheet parameter conversion

| ISO 11898-2:201x | | NXP data sheet | |
|--|--|--|---------------------------------------|
| Parameter | Notation | Symbol | Parameter |
| HS-PMA maximum ratings of V_{CAN_H}, V_{CAN_L} and V_{Diff} | | | |
| Maximum rating V _{Diff} | V _{Diff} | V _(CANH-CANL) | voltage between pin CANH and pin CANL |
| General maximum rating V _{CAN_H} and V _{CAN_L} | V _{CAN_H} | V _x | voltage on pin x |
| Optional: Extended maximum rating V _{CAN_H} and V _{CAN_L} | V _{CAN_L} | | |
| HS-PMA maximum leakage currents on CAN_H and CAN_L, unpowered | | | |
| Leakage current on CAN_H, CAN_L | I _{CAN_H} I _{CAN_L} | I _L | leakage current |
| HS-PMA bus biasing control timings | | | |
| CAN activity filter time, long | t _{Filter} | t _{wake(busdom)} ^[1] | bus dominant wake-up time |
| CAN activity filter time, short | | t _{wake(busrec)} ^[1] | bus recessive wake-up time |
| Wake-up timeout, short | t _{Wake} | t _{to(wake)bus} | bus wake-up time-out time |
| Wake-up timeout, long | | | |
| Timeout for bus inactivity | t _{Silence} | t _{to(silence)} | bus silence time-out time |
| Bus Bias reaction time | t _{Bias} | t _{d(busact-bias)} | delay time from bus active to bias |

[1] t_{fltr(wake)bus} - bus wake-up filter time, in devices with basic wake-up functionality

18. Revision history

Table 11. Revision history

| Document ID | Release date | Data sheet status | Change notice | Supersedes |
|--------------|--------------|--------------------|---------------|------------|
| UJA1162A v.1 | 20190823 | Product data sheet | - | - |

19. Legal information

19.1 Data sheet status

| Document status ^{[1][2]} | Product status ^[3] | Definition |
|-----------------------------------|-------------------------------|---|
| Objective [short] data sheet | Development | This document contains data from the objective specification for product development. |
| Preliminary [short] data sheet | Qualification | This document contains data from the preliminary specification. |
| Product [short] data sheet | Production | This document contains the product specification. |

[1] Please consult the most recently issued document before initiating or completing a design.

[2] The term 'short data sheet' is explained in section "Definitions".

[3] The product status of device(s) described in this document may have changed since this document was published and may differ in case of multiple devices. The latest product status information is available on the Internet at URL <http://www.nxp.com>.

19.2 Definitions

Draft — The document is a draft version only. The content is still under internal review and subject to formal approval, which may result in modifications or additions. NXP Semiconductors does not give any representations or warranties as to the accuracy or completeness of information included herein and shall have no liability for the consequences of use of such information.

Short data sheet — A short data sheet is an extract from a full data sheet with the same product type number(s) and title. A short data sheet is intended for quick reference only and should not be relied upon to contain detailed and full information. For detailed and full information see the relevant full data sheet, which is available on request via the local NXP Semiconductors sales office. In case of any inconsistency or conflict with the short data sheet, the full data sheet shall prevail.

Product specification — The information and data provided in a Product data sheet shall define the specification of the product as agreed between NXP Semiconductors and its customer, unless NXP Semiconductors and customer have explicitly agreed otherwise in writing. In no event however, shall an agreement be valid in which the NXP Semiconductors product is deemed to offer functions and qualities beyond those described in the Product data sheet.

19.3 Disclaimers

Limited warranty and liability — Information in this document is believed to be accurate and reliable. However, NXP Semiconductors does not give any representations or warranties, expressed or implied, as to the accuracy or completeness of such information and shall have no liability for the consequences of use of such information. NXP Semiconductors takes no responsibility for the content in this document if provided by an information source outside of NXP Semiconductors.

In no event shall NXP Semiconductors be liable for any indirect, incidental, punitive, special or consequential damages (including - without limitation - lost profits, lost savings, business interruption, costs related to the removal or replacement of any products or rework charges) whether or not such damages are based on tort (including negligence), warranty, breach of contract or any other legal theory.

Notwithstanding any damages that customer might incur for any reason whatsoever, NXP Semiconductors' aggregate and cumulative liability towards customer for the products described herein shall be limited in accordance with the *Terms and conditions of commercial sale* of NXP Semiconductors.

Right to make changes — NXP Semiconductors reserves the right to make changes to information published in this document, including without limitation specifications and product descriptions, at any time and without notice. This document supersedes and replaces all information supplied prior to the publication hereof.

Suitability for use in automotive applications — This NXP Semiconductors product has been qualified for use in automotive applications. Unless otherwise agreed in writing, the product is not designed, authorized or warranted to be suitable for use in life support, life-critical or safety-critical systems or equipment, nor in applications where failure or malfunction of an NXP Semiconductors product can reasonably be expected to result in personal injury, death or severe property or environmental damage. NXP Semiconductors and its suppliers accept no liability for inclusion and/or use of NXP Semiconductors products in such equipment or applications and therefore such inclusion and/or use is at the customer's own risk.

Applications — Applications that are described herein for any of these products are for illustrative purposes only. NXP Semiconductors makes no representation or warranty that such applications will be suitable for the specified use without further testing or modification.

Customers are responsible for the design and operation of their applications and products using NXP Semiconductors products, and NXP Semiconductors accepts no liability for any assistance with applications or customer product design. It is customer's sole responsibility to determine whether the NXP Semiconductors product is suitable and fit for the customer's applications and products planned, as well as for the planned application and use of customer's third party customer(s). Customers should provide appropriate design and operating safeguards to minimize the risks associated with their applications and products.

NXP Semiconductors does not accept any liability related to any default, damage, costs or problem which is based on any weakness or default in the customer's applications or products, or the application or use by customer's third party customer(s). Customer is responsible for doing all necessary testing for the customer's applications and products using NXP Semiconductors products in order to avoid a default of the applications and the products or of the application or use by customer's third party customer(s). NXP does not accept any liability in this respect.

Limiting values — Stress above one or more limiting values (as defined in the Absolute Maximum Ratings System of IEC 60134) will cause permanent damage to the device. Limiting values are stress ratings only and (proper) operation of the device at these or any other conditions above those given in the Recommended operating conditions section (if present) or the Characteristics sections of this document is not warranted. Constant or repeated exposure to limiting values will permanently and irreversibly affect the quality and reliability of the device.

Terms and conditions of commercial sale — NXP Semiconductors products are sold subject to the general terms and conditions of commercial sale, as published at <http://www.nxp.com/profile/terms>, unless otherwise agreed in a valid written individual agreement. In case an individual agreement is concluded only the terms and conditions of the respective agreement shall apply. NXP Semiconductors hereby expressly objects to applying the customer's general terms and conditions with regard to the purchase of NXP Semiconductors products by customer.

No offer to sell or license — Nothing in this document may be interpreted or construed as an offer to sell products that is open for acceptance or the grant, conveyance or implication of any license under any copyrights, patents or other industrial or intellectual property rights.

Export control — This document as well as the item(s) described herein may be subject to export control regulations. Export might require a prior authorization from competent authorities.

Translations — A non-English (translated) version of a document is for reference only. The English version shall prevail in case of any discrepancy between the translated and English versions.

19.4 Trademarks

Notice: All referenced brands, product names, service names and trademarks are the property of their respective owners.

20. Contact information

For more information, please visit: <http://www.nxp.com>

For sales office addresses, please send an email to: salesaddresses@nxp.com

21. Contents

| | | | | | |
|-----------|---|-----------|-----------|--|-----------|
| 1 | General description | 1 | 11.1 | Application diagram | 22 |
| 2 | Features and benefits | 1 | 12 | Test information | 23 |
| 2.1 | General | 1 | 12.1 | Quality information | 23 |
| 2.2 | Designed for automotive applications | 1 | 13 | Package outline | 24 |
| 2.3 | Integrated supply voltage for the CAN transceiver (V _{BUF}) | 2 | 14 | Handling information | 25 |
| 2.4 | Power Management | 2 | 15 | Soldering of SMD packages | 25 |
| 2.5 | System control and diagnostic features | 2 | 15.1 | Introduction to soldering | 25 |
| 3 | Ordering information | 2 | 15.2 | Wave and reflow soldering | 25 |
| 4 | Block diagram | 3 | 15.3 | Wave soldering | 25 |
| 5 | Pinning information | 4 | 15.4 | Reflow soldering | 26 |
| 5.1 | Pinning | 4 | 16 | Soldering of HVSON packages | 27 |
| 5.2 | Pin description | 4 | 17 | Appendix: ISO 11898-2:201x parameter cross-reference list | 28 |
| 6 | Functional description | 5 | 18 | Revision history | 30 |
| 6.1 | System controller | 5 | 19 | Legal information | 31 |
| 6.1.1 | Operating modes | 5 | 19.1 | Data sheet status | 31 |
| 6.1.1.1 | Normal mode | 5 | 19.2 | Definitions | 31 |
| 6.1.1.2 | Standby mode | 6 | 19.3 | Disclaimers | 31 |
| 6.1.1.3 | Sleep mode | 7 | 19.4 | Trademarks | 32 |
| 6.1.1.4 | Off mode | 7 | 20 | Contact information | 32 |
| 6.1.1.5 | Overtemp mode | 7 | 21 | Contents | 33 |
| 6.1.1.6 | Hardware characterization for the UJA1162A operating modes | 8 | | | |
| 6.1.2 | Mode control via pin SLPN | 8 | | | |
| 6.2 | Power supplies | 8 | | | |
| 6.2.1 | Battery supply voltage (V _{BAT}) | 8 | | | |
| 6.2.2 | CAN supply voltage (V _{BUF}) | 8 | | | |
| 6.3 | High-speed CAN transceiver | 8 | | | |
| 6.3.1 | CAN operating modes | 9 | | | |
| 6.3.1.1 | CAN Active mode | 9 | | | |
| 6.3.1.2 | CAN Offline and Offline Bias modes | 9 | | | |
| 6.3.1.3 | CAN Off mode | 10 | | | |
| 6.3.2 | CAN standard wake-up | 10 | | | |
| 6.4 | WAKE pin | 11 | | | |
| 6.5 | VIO supply pin | 11 | | | |
| 6.6 | CAN transceiver status pin (CTS) | 12 | | | |
| 6.7 | CAN fail-safe features | 12 | | | |
| 6.7.1 | TXD dominant timeout | 12 | | | |
| 6.7.2 | Pull-up on TXD pin | 12 | | | |
| 6.7.3 | Pull-down on SLPN pin | 12 | | | |
| 6.7.4 | Loss of power at pin BAT | 12 | | | |
| 7 | Limiting values | 13 | | | |
| 8 | Thermal characteristics | 15 | | | |
| 9 | Static characteristics | 15 | | | |
| 10 | Dynamic characteristics | 19 | | | |
| 11 | Application information | 22 | | | |

Please be aware that important notices concerning this document and the product(s) described herein, have been included in section 'Legal information'.

© NXP Semiconductors N.V. 2019. All rights reserved.

For more information, please visit: <http://www.nxp.com>
 For sales office addresses, please send an email to: salesaddresses@nxp.com

Date of release: 23 August 2019
 Document identifier: UJA1162A

