

MAX V CPLD Development Kit

Altera's MAX® V CPLD Development Kit provides a comprehensive, low-cost hardware platform to quickly begin developing low-cost, low-power CPLD designs. With this platform, you can:

- Develop designs for the 5M570Z CPLD.
- Measure CPLD power (VCCINT and VCCIO).
- Bridge between two different I/O voltages (adjustable VCCIO on CPLD Bank 2).
- Interface to external functions and devices, via four connectors.
- Read and write to memories:
 - 8-kilobits (Kb) user flash memory (UFM) available within 5M570Z CPLD
 - I2C or SPI EEPROMs (user installed)
- Come up to speed quickly with your CPLD design by reusing the example designs provided by the kit's Board Test System.
- Reuse the kit's PCB board and schematic as model for your design.

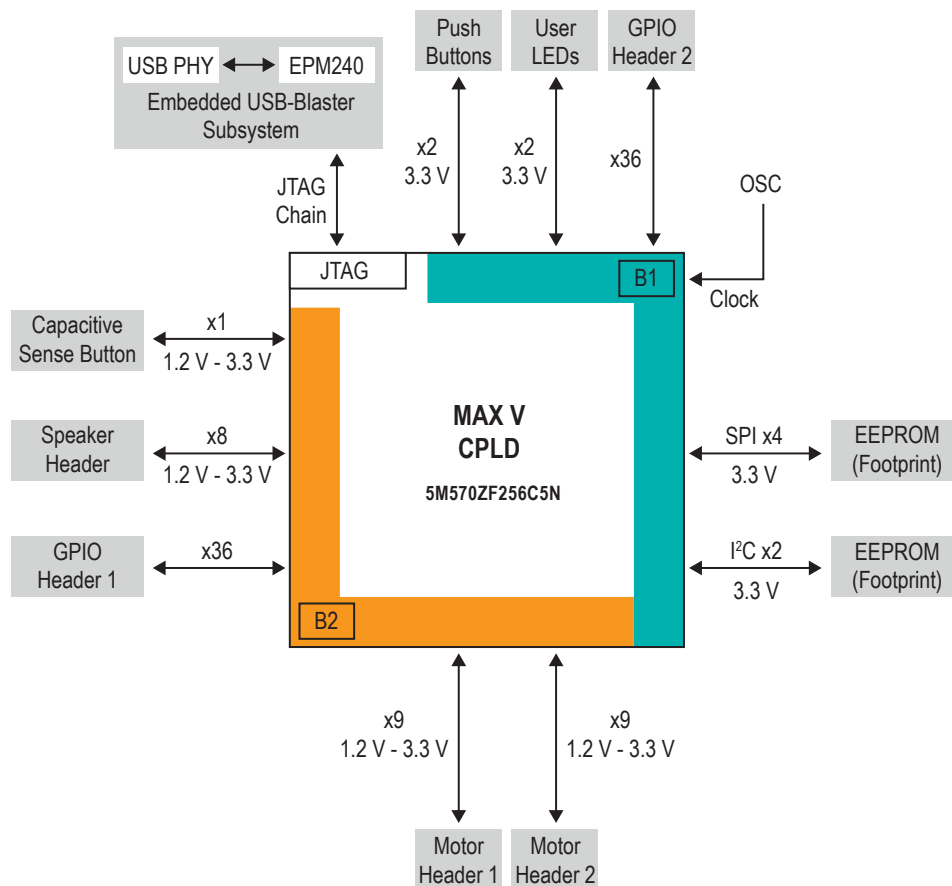
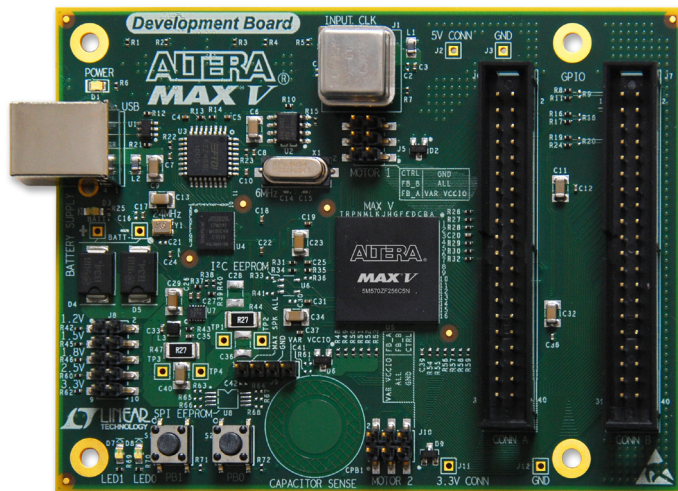

Table 1. Altera's MAX V CPLD Development Kit Ordering Information

Ordering Code	List Price	Information
DK-DEV-5M570ZN	\$74.95	Pre-orders accepted: Dec. 2010 Initial kit shipments: Feb. 2011

Development Kit Contents

- MAX V CPLD development board (Figure 1)
 - MAX V device: 5M570Z, -5 speed, 256-pin FineLine BGA (FBGA) package
 - Configuration - Embedded USB-Blaster™ circuitry (JTAG)
 - Communication – USB port (type B)
 - Clocks:
 - Single-ended 10-MHz oscillator (4-pin, socket mounted)
 - CPLD internal oscillator 4.4 MHz (typical, user configurable frequency)
- Multiple expansion connectors:
 - Two general-purpose headers (2X 20-pin)
 - Standard PC speaker header (4-pin)
 - Two direct current (DC) motor headers (6-pin)
- Memories (not including the kit, PCB footprint only, optional customer installation):
 - I²C EEPROM
 - SPI EEPROM
- Power – USB cable (included, Type A-B)
- Power measuring circuitry
- User-controlled push buttons, a capacitive sense push button, and LEDs
- Restriction of hazardous substances (RoHS) compliant board and contents
- MAX V CPLD Development Kit software content
 - GUI-based Board Test System to exercise selected on-board components
 - User guide, reference manual, board schematics, layout, and design files
- Quartus® II Web Edition design software
 - Free and downloadable from www.altera.com



Altera Corporation

101 Innovation Drive
San Jose, CA 95134
USA
Telephone: (408) 544-7000
www.altera.com

Altera European Headquarters

Holmers Farm Way
High Wycombe
Buckinghamshire
HP12 4XF
United Kingdom
Telephone: (44) 1494 602000

Altera Japan Ltd.

Shinjuku i-Land Tower 32F
6-5-1, Nishi-Shinjuku
Shinjuku-ku, Tokyo 163-1332
Japan
Telephone: (81) 3 3340 9480
www.altera.co.jp

Altera International Ltd.

Unit 11-18, 9/F
Millennium City 1, Tower 1
388 Kwun Tong Road
Kwun Tong
Kowloon, Hong Kong
Telephone: (852) 2945 7000

