

REVISIONS

P	LTR	DESCRIPTION	DATE	DWN	APVD
-	-	SEE SHEET 1	-	-	-

WITH POLYAMIDE TAPE

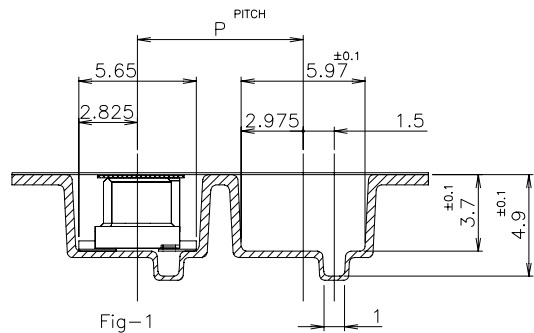
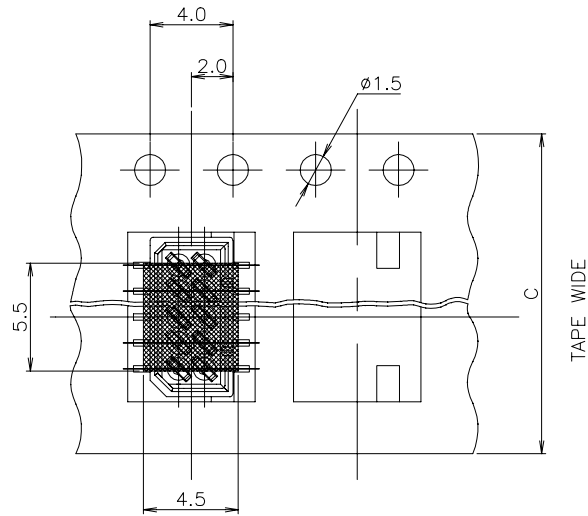

TOP OF REEL

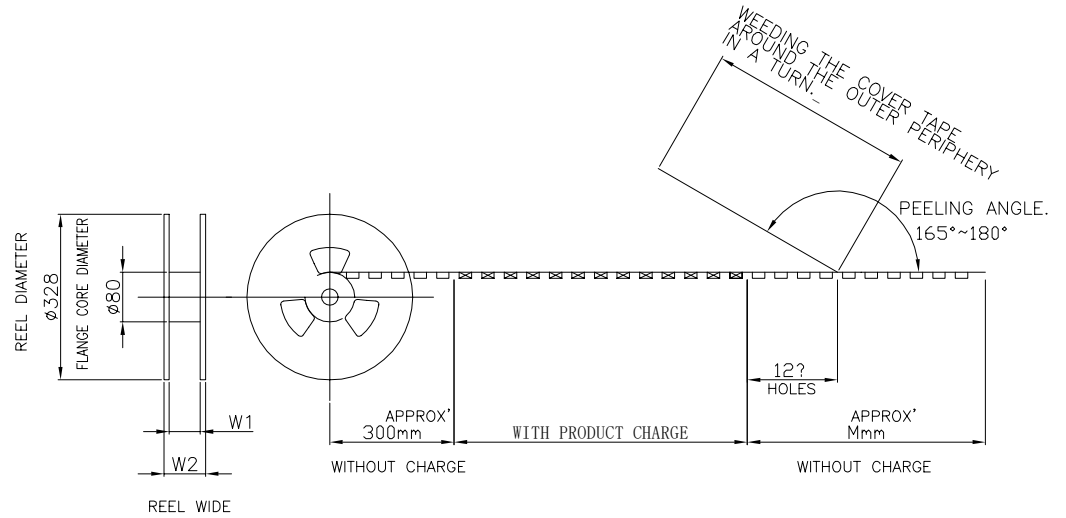

WEEDING THE COVER TAPE AROUND THE OUTER PERIPHERY IN A TURN.
 PEELING ANGLE 165°~180°

29	26	600	12	24	1000	16	720999-9	4-	-6	9-	-6	
21	18	300	8	24	1500	14	2-720999-2	4-	-4	4-	-4	
(H1)	21	18	300	8	16	1500	12	720999-8	4-	-2	9-	-2
(H1)	21	18	300	8	16	1500	10	1-720999-1	4-174904-0	9-175630-0		
	W ₂	W ₁	M	P	C	QTY/REEL	Pos.	EMBOSS TAPE P/N	CONNECTOR P/N	SALABLE TAPING P/N		

THIS DRAWING IS A CONTROLLED DOCUMENT.

DWN J.TANIGAWA 28MAY88		TE Connectivity Ltd.	
CHK S.KIKUCHI 30MAY88			
APVD N.ONOUE 30MAY88		NAME	
PRODUCT SPEC		ON TAPING (EMBOSS)1.25 F-P CONNECTOR B-TO-B DOUBLE ROW REC HDR ASS'Y (V) SMT TYPE WITHOUT BOSS, W/CAP	
APPLICATION SPEC		SIZE A3	CAGE CODE 00779
WEIGHT		DRAWING NO. C=175630	
MATERIAL		RESTRICTED TO	
FINISH		CUSTOMER DRAWING	
		SCALE NON	SHEET 2 OF 2
		REV H1	