

REVISIONS				
P.	LTN.	DESCRIPTION	DATE	OWN. APVD.
A		RELEASED PER ECO-16-009324	07NOV2016	DD JT

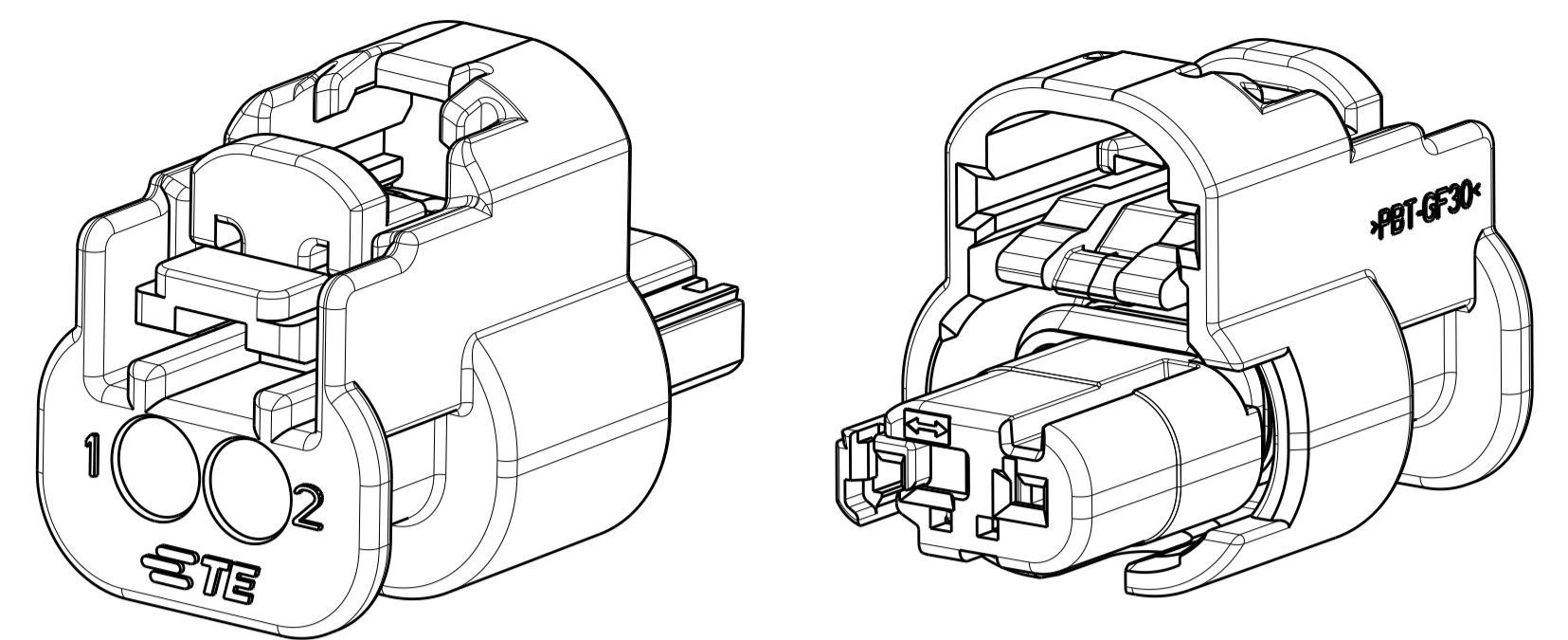

REF VIEW
SCALE 4:1

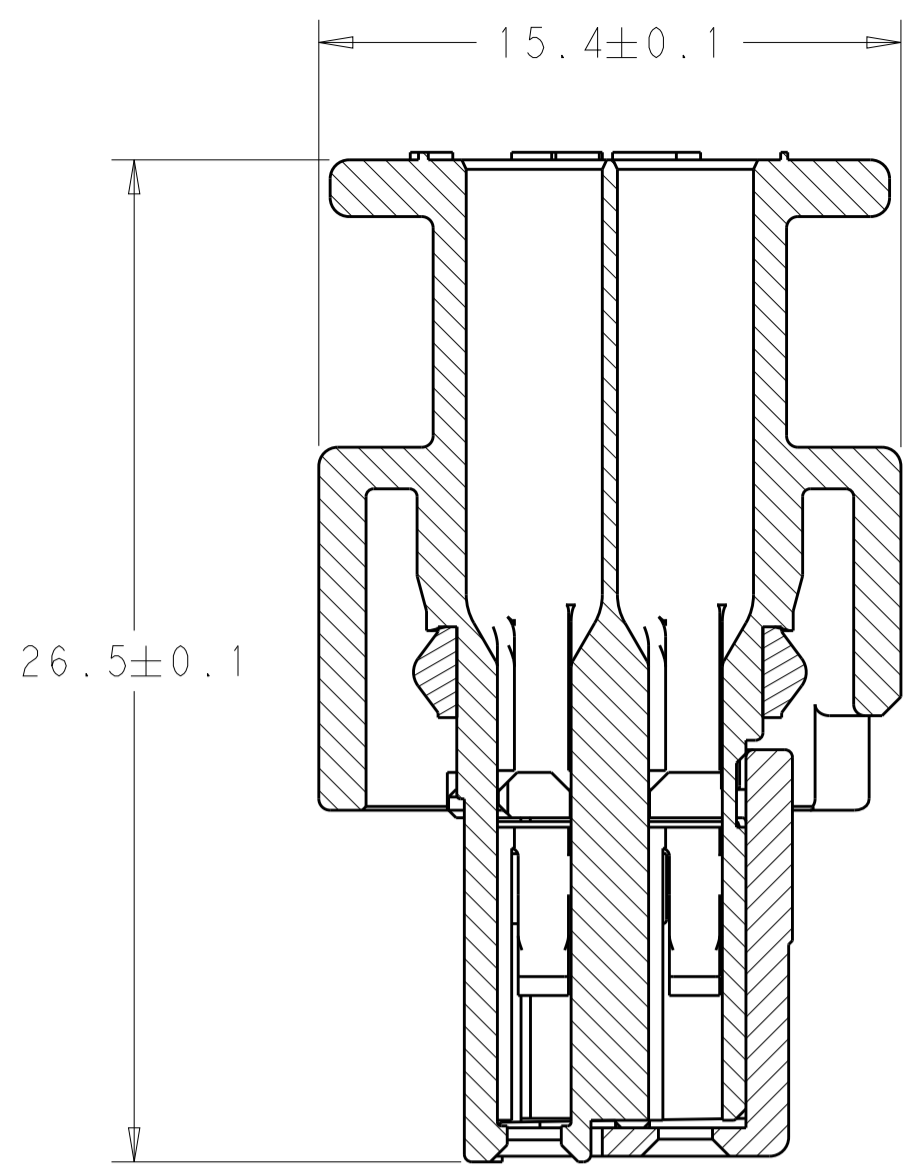

SECTION E-E
SHOWN WITH ISL IN
FINAL POSITION

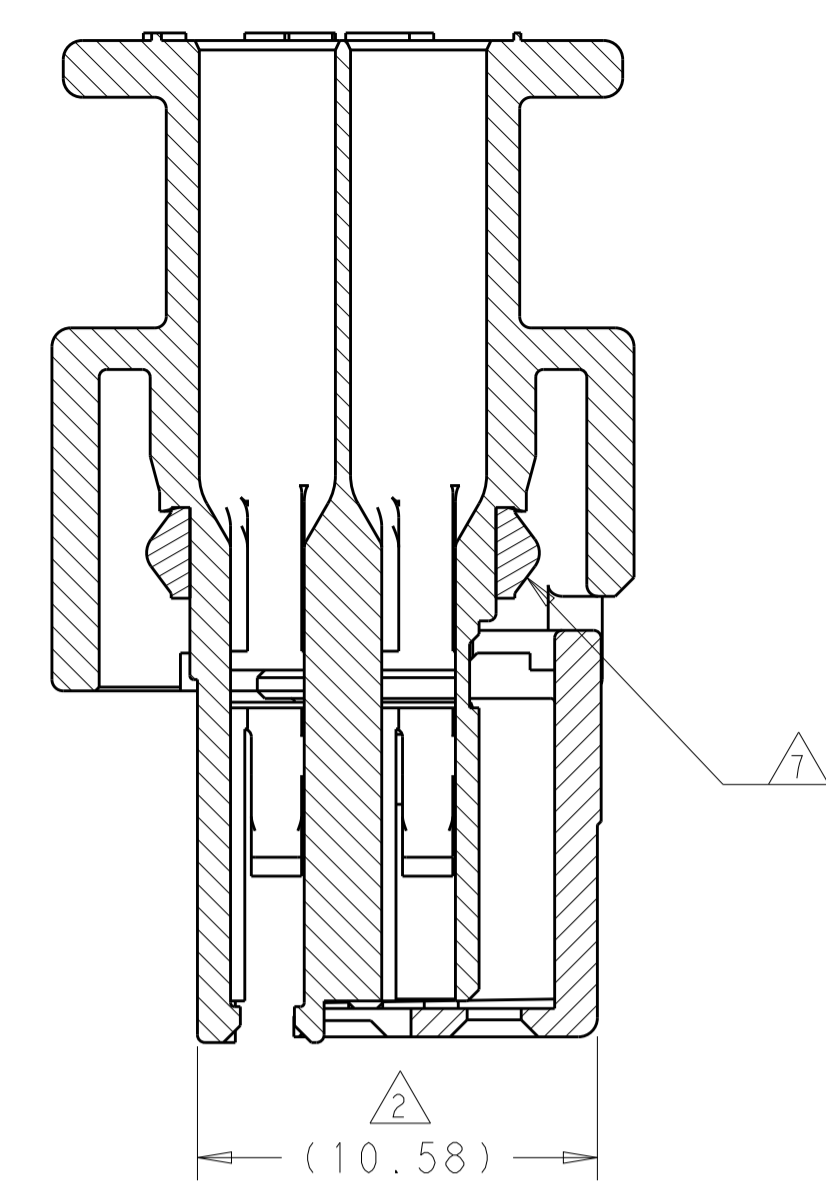

SECTION E-E
SHOWN WITH ISL IN
SHIPPING POSITION

- PART NUMBER 1-2304514-1 SHOWN ON DRAWING.
- TPA AND CPA (OPTIONAL) ARE SHIPPED IN THEIR PRE-LATCHED POSITIONS. SEE INSTRUCTION SHEET 408-8968 FOR DIRECTIONS ON MOVING THE CPA AND TPA TO THE PRE-LATCHED POSITION, IF NECESSARY.
- TERMINALS SOLD SEPARATELY. FOR USE WITH TE MCON 1.2mm CLEAN BODY CONTACT WITH WIRE SEAL. SEE TE MCON 1.2-CB (CLEAN BODY) APPLICATION SPEC 114-18464 FOR CRIMP DETAILS.
- SEE USCAR DRAWING 120-S-002-1-Z01 FOR MATING INTERFACE DETAILS.
- MINIMUM FEED THROUGH CONDITION WITH 1.0mm CLEARANCE ALL AROUND.
- CONNECTOR APPLICATION ENVIRONMENT IS SUBMERSION IN ENGINE OIL. FOR REQUIRED MECHANICAL STABILITY AND FLUID COMPATIBILITY, INDIVIDUAL WIRE SEALS PRODUCED FROM ETHYLENE / ACRYLIC (AEM) BASE MATERIALS ARE REQUIRED PER TERMINAL P/N TABLE.
- CONNECTOR HAS FLUOROSILICONE SEAL INTENDED TO PERFORM IN AN OIL ENVIRONMENT VIBRATION DAMPENING. SEAL CONTAINS LESS THAN 1% SILICONE VOLATILES BY WEIGHT. SEAL IS COATED WITH OSIXO DRY LUBRICANT FOR MATING PURPOSES. SEALING IS NOT GUARANTEED.
- LIFT ISL AND AWAY FROM PLUG AND MOVE THE RIGHT 2.0mm.
- MATES WITH STRAIGHT EXIT WIRE DRESS, TE PN 2272168-1 AND RIGHT ANGLE EXIT WIRE DRESS, TE PN 2272169-1

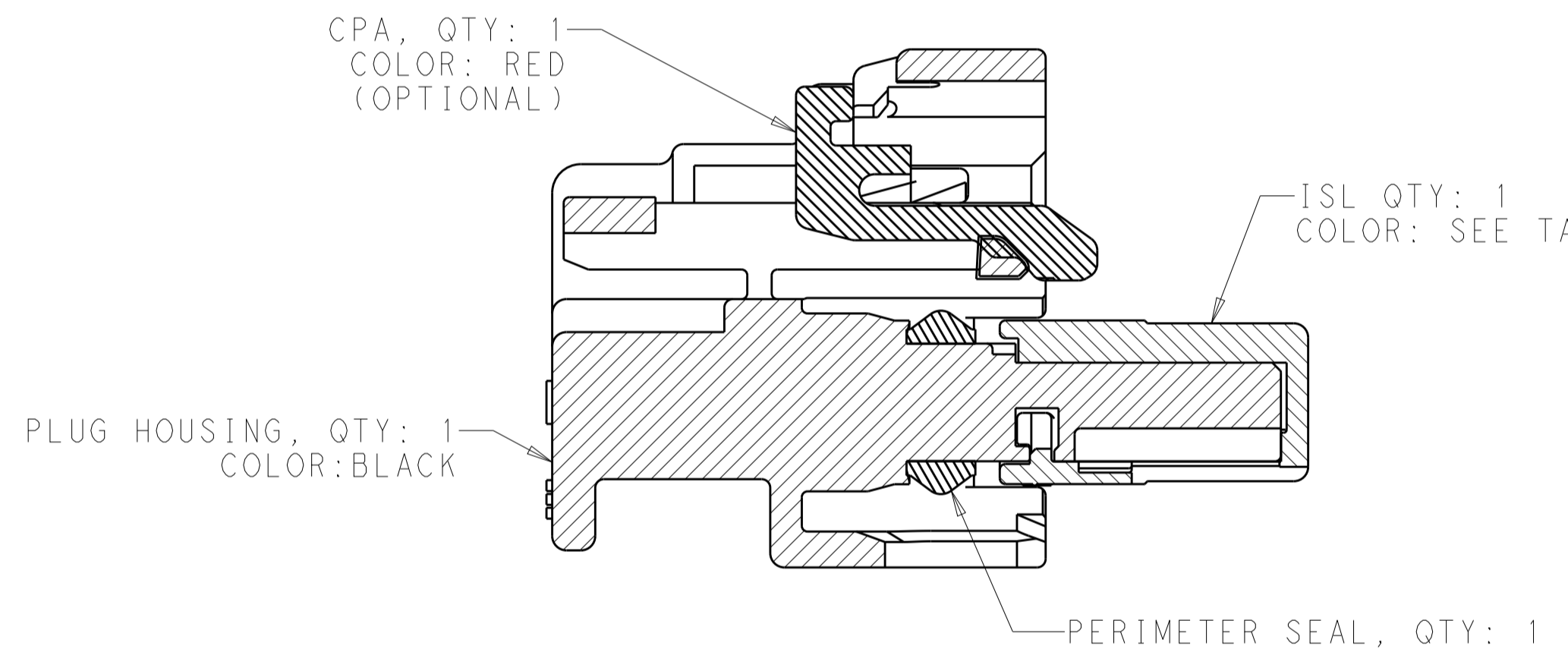

SECTION D-D
SHOWN WITH CPA IN
LATCHED POSITION

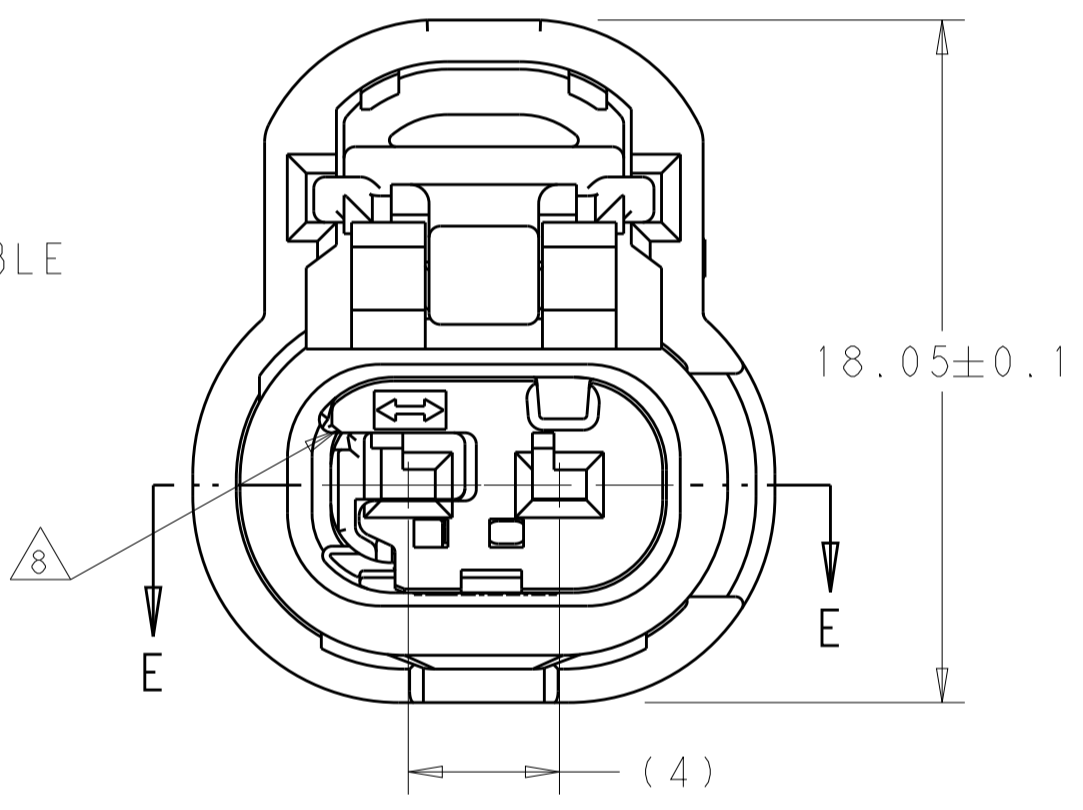

ISL SHOWN IN
FINAL POSITION

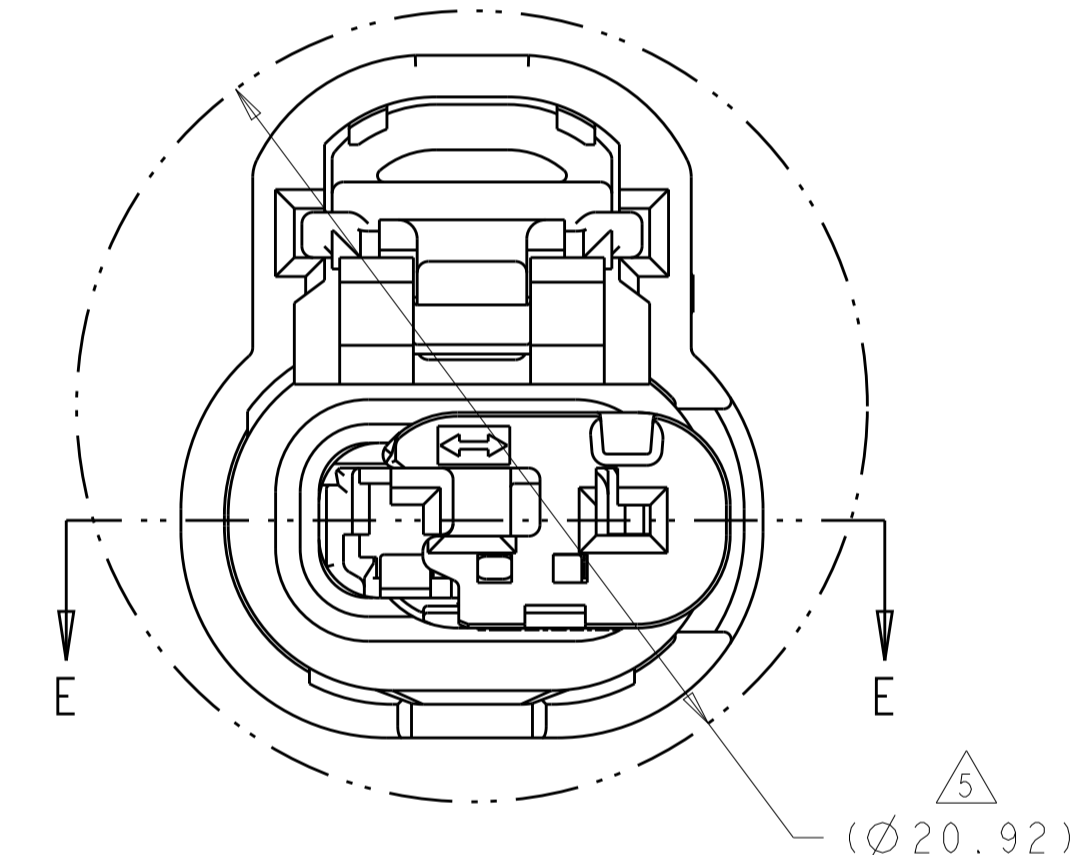

ISL SHOWN IN
PRE-LATCHED POSITION REF ONLY

KEYING CONFIGURATIONS

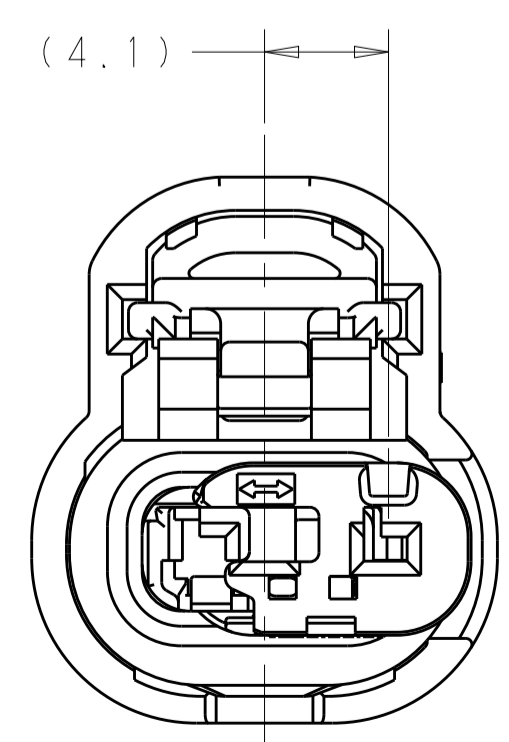

SCALE 4:1

KEYING OPTION A

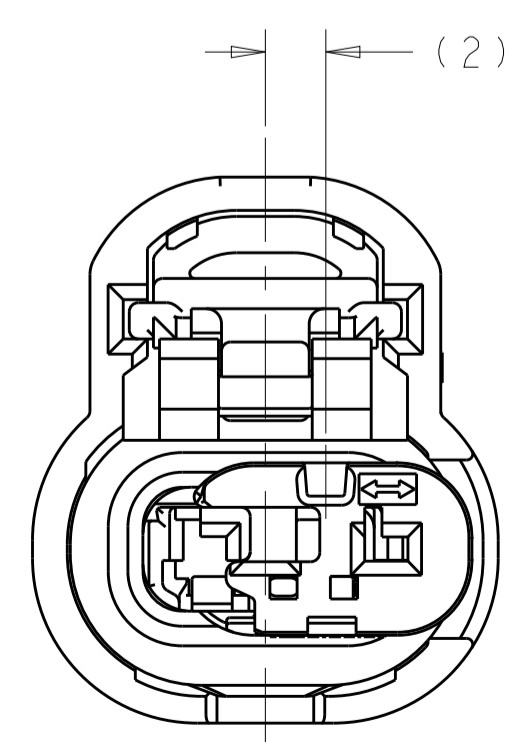

SCALE 4:1

KEYING OPTION B

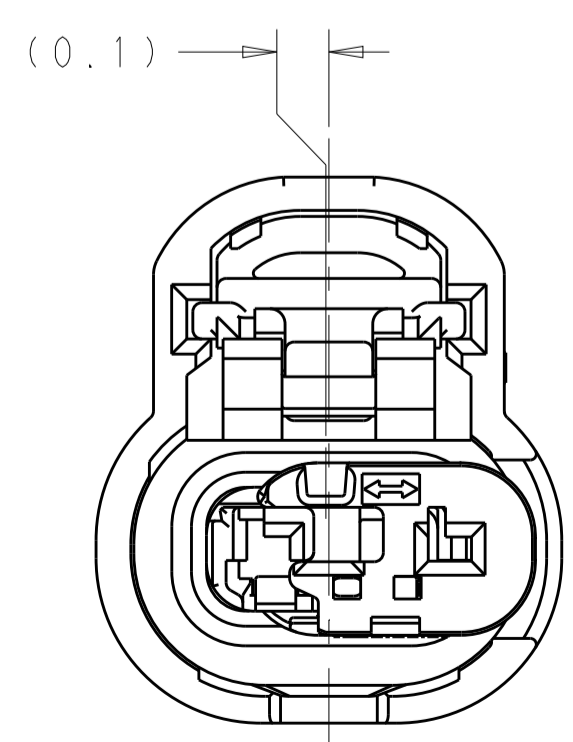

SCALE 4:1

KEYING OPTION C

TE MCON 1.2-CB (CLEAN BODY)		
1670146-3		
1670146-2	(0.5-0.75)	2138898-1
1670146-1		
PART NUMBER	METRIC WIRE SIZE	APPLICABLE WIRE SEAL

YES	DK GRAY	KEY CODE "C"	1-2304514-3
YES	LT GRAY	KEY CODE "B"	1-2304514-2
YES	BLUE	KEY CODE "A"	1-2304514-1
N/A	DK GRAY	KEY CODE "C"	2304514-3
N/A	LT GRAY	KEY CODE "B"	2304514-2
N/A	BLUE	KEY CODE "A"	2304514-1
CPA	ISL COLOR	KEY CONFIGURATION	PART NUMBER

THIS DRAWING IS A CONTROLLED DOCUMENT. OWN: D. DRUMMOND 07NOV2016. CHK: J.L. TONEY 07NOV2016. APVD: J.L. TONEY 07NOV2016.

STE TE Connectivity

NAME: PLUG ASSEMBLY, FEMALE, 2 POSITION, OIL SUBMERSIBLE

SIZE: A1 00779 C=2304514

SCALE: 5:1 SHEET 1 OF 1 REV A