

Hybrid motor starter - ELR H5-IES-SC- 24DC/500AC-0,6 - 2900582

Please be informed that the data shown in this PDF Document is generated from our Online Catalog. Please find the complete data in the user's documentation. Our General Terms of Use for Downloads are valid (<http://phoenixcontact.com/download>)



Hybrid motor starter for reversing 3~ AC motors up to 500 V AC and 0.6 A output current, with 24 V DC control voltage, adjustable overload shutdown, emergency stop function to SIL 3/PL e, and screw connection.

Your advantages

- ✓ 22.5 mm wide
- ✓ Safety level according to IEC 61508-1: SIL 3, ISO 13849: PL e
- ✓ Reduction in wiring
- ✓ Long service life
- ✓ Space saving
- ✓ 3-phase loop bridges
- ✓ Adjustable current for bimetal function
- ✓ Low-wear switching



Key Commercial Data

Packing unit	1 pc
GTIN	
GTIN	4046356526289

Technical data

Dimensions

Width	22.5 mm
Height	106.6 mm
Depth	113.7 mm

Ambient conditions

Ambient temperature (operation)	-25 °C ... 70 °C (observe derating)
Ambient temperature (storage/transport)	-40 °C ... 80 °C
Maximum altitude	≤ 2000 m
Degree of protection	IP20

Hybrid motor starter - ELR H5-IES-SC- 24DC/500AC-0,6 - 2900582

Technical data

Device supply

Rated control circuit supply voltage U_s	24 V DC
Control supply voltage range	19.2 V DC ... 30 V DC
Rated control supply current I_s	40 mA
Type of protection	Surge protection
	Reverse polarity protection

Input data

Input name	Control input right/left
Rated actuating voltage U_c	24 V DC
Triggering voltage range	19.2 V DC ... 30 V DC
Rated actuating current I_c	5 mA (Input type 1)
Switching threshold	9.6 V ("0" signal)
	19.2 V ("1" signal)
Switching level	< 5 V DC (For EMERGENCY STOP)
Typical turn-off time	< 30 ms
Type of protection	Reverse polarity protection

Output data load output

Output name	AC output
Rated operating voltage U_e	500 V AC
Operating voltage range	42 V AC ... 550 V AC
Rated operating current I_e	0.6 A (AC-51)
	0.6 A (AC-53a)
Mains frequency	50/60 Hz
Load current range	75 mA ... 600 mA (see to derating)
Trigger characteristic in acc. with IEC 60947-4-2	Class 10A
Cooling time	20 min. (for auto reset)
Leakage current	0 mA
Type of protection	Surge protection

Output data reply output

Output name	Acknowledge output
Note	Confirmation: floating change-over contact, signal contact
Contact type	1 PDT
Switching capacity according to IEC 60947-5-1	3 A (230 V, AC15)
	2 A (24 V, DC13)

General

Motor starter type	Reversing starter
Switching frequency	≤ 2 Hz (Load-dependent)
Mounting position	vertical (horizontal DIN rail, motor output below)
Mounting type	DIN rail mounting
Assembly instructions	alignable, for spacing see derating

Hybrid motor starter - ELR H5-IES-SC- 24DC/500AC-0,6 - 2900582

Technical data

General

Operating mode	100% operating factor
Maximum power dissipation	1.5 W
Minimum power dissipation	1.1 W
Operating voltage display	Green LED
Status display	Yellow LED
Indication	Red LED

Connection data

Connection name	Control circuits
Connection method	Screw connection
Stripping length	8 mm
Screw thread	M3
Conductor cross section solid	0.2 mm ² ... 2.5 mm ²
Conductor cross section flexible	0.2 mm ² ... 2.5 mm ²
Conductor cross section AWG	24 ... 14
Torque	0.5 Nm ... 0.6 Nm

Connection data 2

Connection name	Load circuit
Connection method	Screw connection
Stripping length	8 mm
Screw thread	M3
Conductor cross section solid	0.2 mm ² ... 2.5 mm ²
Conductor cross section flexible	0.2 mm ² ... 2.5 mm ²
Conductor cross section AWG	24 ... 14
Torque	0.5 Nm ... 0.6 Nm

Insulation characteristics

Rated insulation voltage	500 V
Rated surge voltage	6 kV
Overvoltage category	III
Degree of pollution	2
Designation	Insulation characteristics between the control input and control supply voltage, and auxiliary circuit to the main circuit
Insulation	Safe isolation (IEC 60947-1/EN 50178) at operating voltage ≤ 300 V AC
	Basic isolation (IEC 60947-1) at operating voltage 300 ... 500 V AC
	Safe isolation (EN 50178) at operating voltage 300 ... 500 V AC
Designation	Isolation characteristics between the control input and control supply voltage to auxiliary circuit
Insulation	Safe isolation (IEC 60947-1) in the auxiliary circuit ≤ 300 V AC
	Safe isolation (EN 50178) in the auxiliary circuit ≤ 300 V AC

Standards and Regulations

Designation	Standards/regulations
-------------	-----------------------

Hybrid motor starter - ELR H5-IES-SC- 24DC/500AC-0,6 - 2900582

Technical data

Standards and Regulations

Standards/regulations	IEC 60947-1
	IEC 60947-4-2
	IEC 61508
	ISO 13849

Conformance/approvals

Designation	ATEX
Identification	# II (2) G [Ex e] [Ex d] [Ex px]
	# II (2) D [Ex t] [Ex p]
Certificate	PTB 07 ATEX 3145
Designation	UL approval
Certificate	NLDX.E228652
Designation	Safety Integrity Level (SIL, IEC 61508)
Identification	≤ 3
Additional text	Safe shutdown
Designation	Safety Integrity Level (SIL, IEC 61508)
Identification	2
Additional text	Motor protection
Designation	Performance Level (ISO 13849)
Identification	≤ e
Additional text	Safe shutdown
Designation	Category (ISO 13849)
Identification	≤ 3
Additional text	Safe shutdown

UL data

SCCR	100 kA (500 V AC (fuse: 30 A class CC/30 A class J (high fault)))
	5 kA (500 V AC (fuse: 20 A RK5 (standard fault)))
FLA	0.6 A (500 V AC)
Group installation	20 A (class RK5, SCCR 5kA, #24 - 14 AWG max. solid and stranded)
	30 A (class CC or J, SCCR 100kA, #24 - 14 AWG max, solid and stranded)
Category code	NLDX

Environmental Product Compliance

China RoHS	Environmentally Friendly Use Period = 50
	For details about hazardous substances go to tab "Downloads", Category "Manufacturer's declaration"

Drawings

Hybrid motor starter - ELR H5-IES-SC- 24DC/500AC-0,6 - 2900582

Circuit diagram

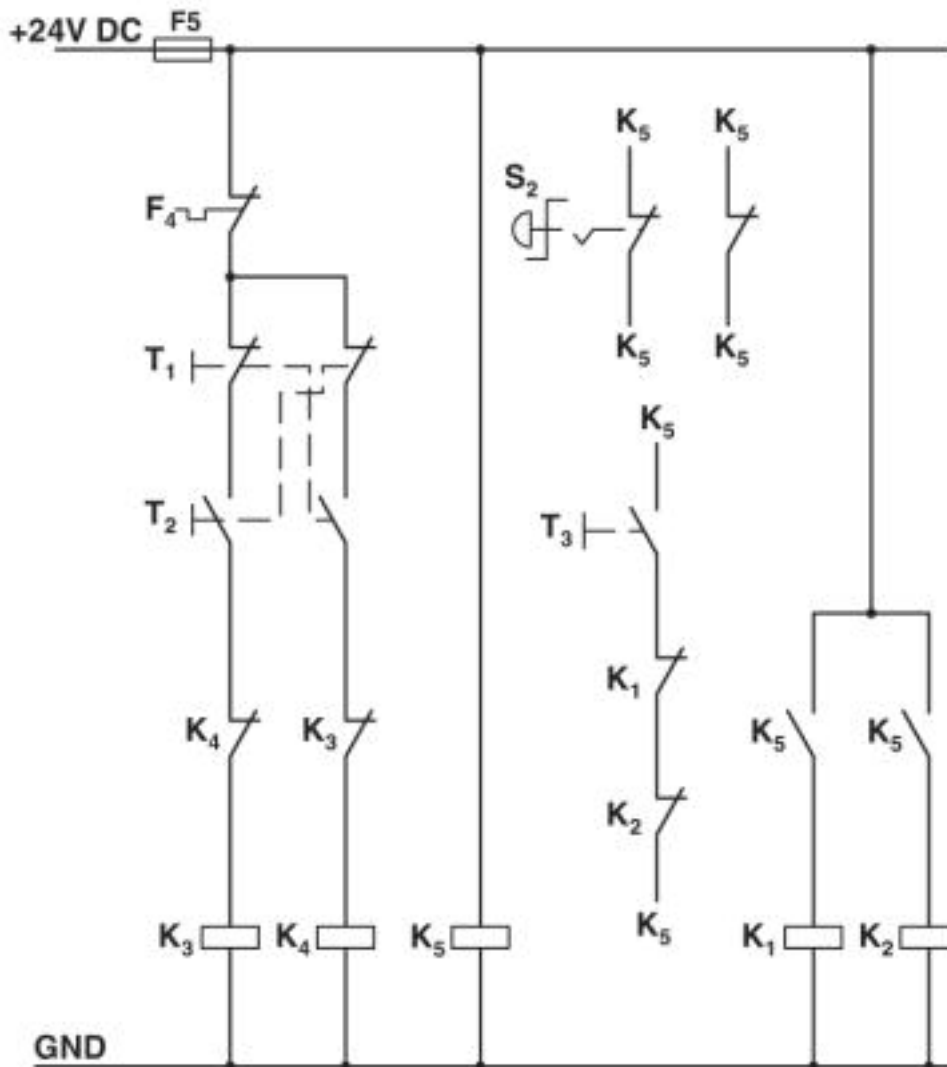

Conventional structure
Control current path reversing contactor according to category 3

- K1 + K2 = Emergency stop contactor
- K3 = Left contactor
- K4 = Right contactor
- K5 = PSR SCP-24DC.../Safety relay
- T1 = Right, T2 = Left, T3 = Reset
- S2 = Emergency stop
- F4 = Motor protection relay

Hybrid motor starter - ELR H5-IES-SC- 24DC/500AC-0,6 - 2900582

Circuit diagram

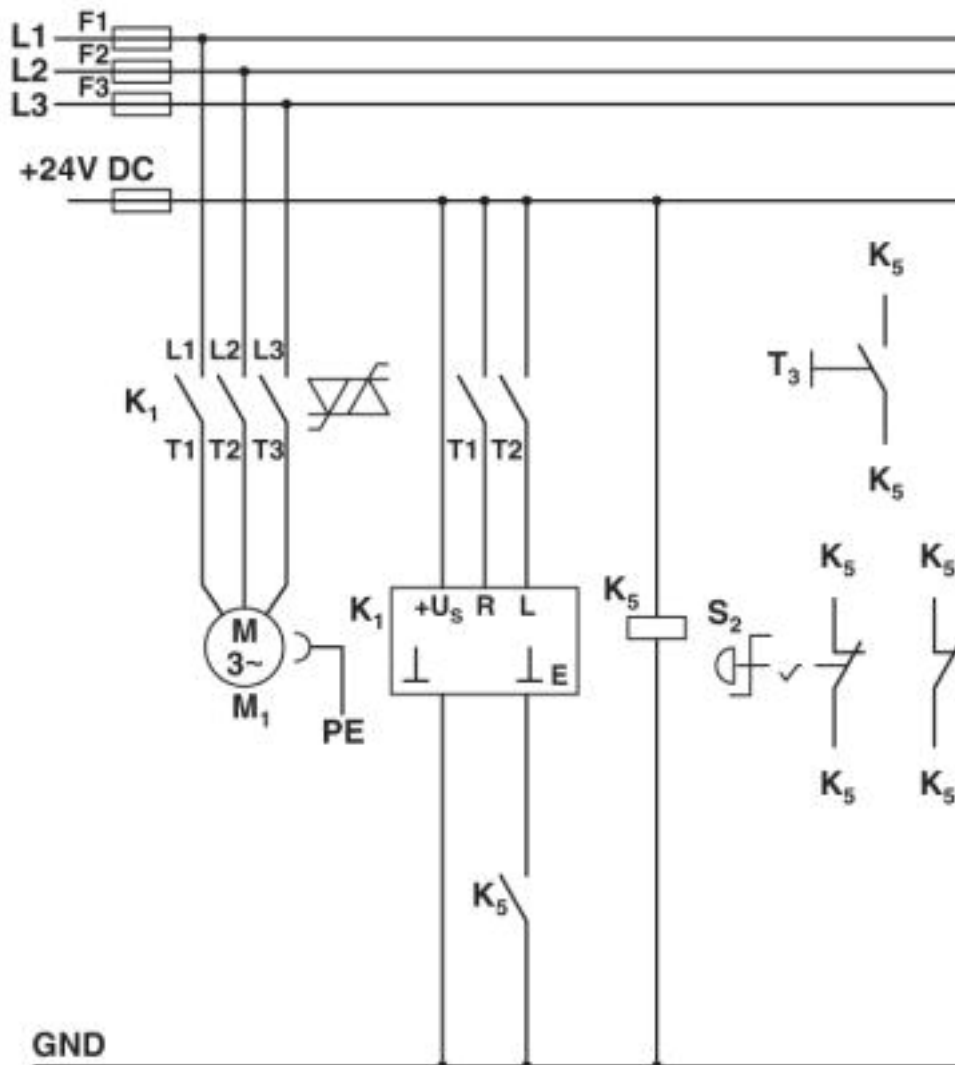

Structure with CONTACTRON

Main and control current path for '4 in 1' hybrid motor starter with reversing function according to category 3

K1 = '4 in 1' hybrid motor starter with reversing function

K5 = PSR SCP-24DC.../Safety relay

T1 = Right, T2 = Left, T3 = Reset

S2 = Emergency stop

Hybrid motor starter - ELR H5-IES-SC- 24DC/500AC-0,6 - 2900582

Circuit diagram

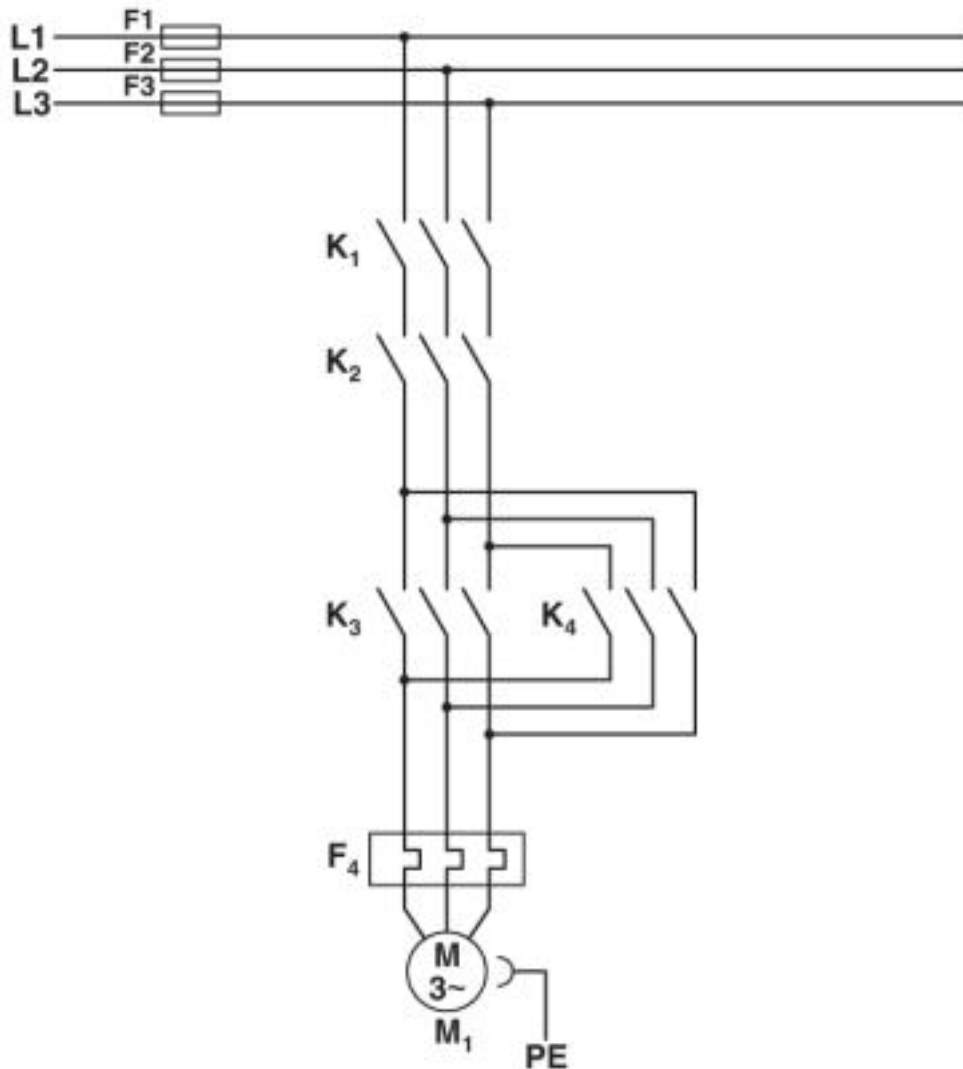

Conventional structure
Main current path for reversing contactor according to category 3

- K1 + K2 = Emergency stop contactor
- K3 = Left contactor
- K4 = Right contactor
- F4 = Motor protection relay

Hybrid motor starter - ELR H5-IES-SC- 24DC/500AC-0,6 - 2900582

Block diagram

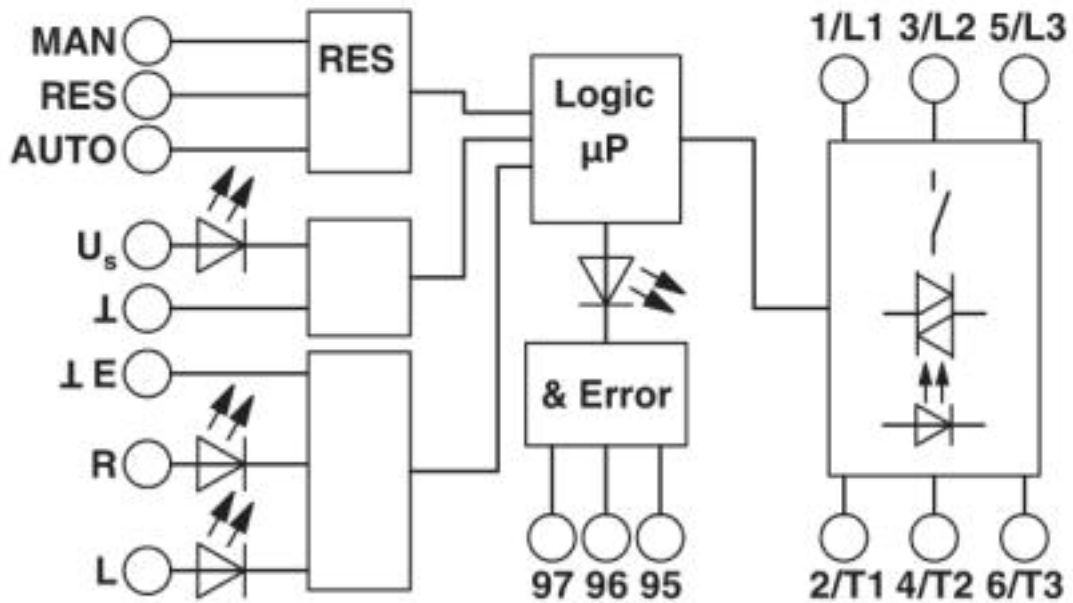

Diagram

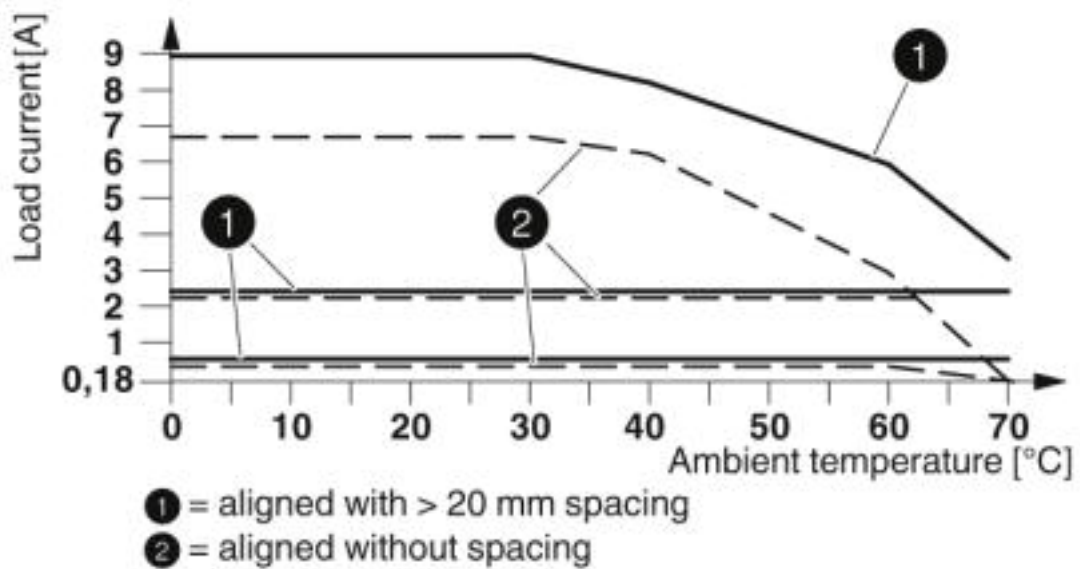

Derating diagram

Approvals

Approvals

Approvals

UL Listed / cUL Listed / GL / GL-SW / UL Listed / IECEE CB Scheme / cUL Listed / CCC / EAC / GL

Hybrid motor starter - ELR H5-IES-SC- 24DC/500AC-0,6 - 2900582

Approvals

Ex Approvals

ATEX

Approval details

UL Listed		http://database.ul.com/cgi-bin/XYV/template/LISEXT/1FRAME/index.htm	FILE E 228652
cUL Listed		http://database.ul.com/cgi-bin/XYV/template/LISEXT/1FRAME/index.htm	FILE E 228652
GL		https://approvalfinder.dnvgl.com/	54757-08 HH
GL-SW			54757-08 HH
UL Listed		http://database.ul.com/cgi-bin/XYV/template/LISEXT/1FRAME/index.htm	FILE E 323771
IECEE CB Scheme		http://www.iecee.org/	DE1-55728
cUL Listed		http://database.ul.com/cgi-bin/XYV/template/LISEXT/1FRAME/index.htm	FILE E 323771
CCC			2016010304871315
EAC			RU C- DE.A*30.B.01082

Hybrid motor starter - ELR H5-IES-SC- 24DC/500AC-0,6 - 2900582

Approvals

GL



Phoenix Contact 2019 © - all rights reserved
<http://www.phoenixcontact.com>

PHOENIX CONTACT GmbH & Co. KG
Flachsmarktstr. 8
32825 Blomberg
Germany
Tel. +49 5235 300
Fax +49 5235 3 41200
<http://www.phoenixcontact.com>