

PART NUMBER	REVISION	DESCRIPTION	FEED TYPE
2266301-1	B	FINE CRIMP HEIGHT ADJUST	MECHANICAL
2266301-2	B	FINE CRIMP HEIGHT ADJUST	PNEUMATIC
7-2266301-1	B	MECHANICAL AND CRIMP TOOLING KIT	MECHANICAL
7-2266301-2	B	PNEUMATIC AND CRIMP TOOLING KIT	PNEUMATIC
7-2266301-7	A	CRIMP TOOLING KIT	-

ATLANTIC VERSION TERMINATOR INTERFACE ADAPTER

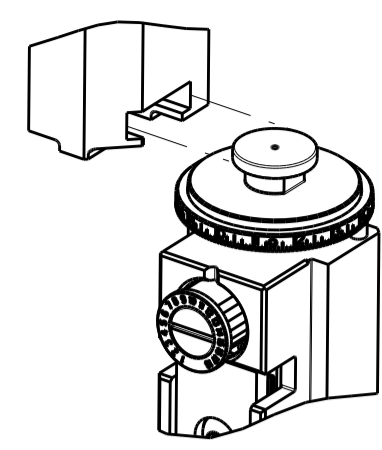

APPLICATOR DATA		
CRIMP	SIZE	TYPE
WIRE	1.78 mm [.070]	F
INSUL	2.54 mm [.100]	O

APPLICATOR INSTRUCTIONS
408-35042

TERMINAL DATA: WERI TERMINAL		TE CRIMP SPECIFICATION	
TERMINAL NAME: 3.96MM FEMALE TERMINAL			
WIRE STRIP LENGTH		INSULATION DIAMETER RANGE	
2.91-3.67 mm [.114-.144 IN]		Ø1.77-2.37 mm [.070-.093 IN]	
TERMINAL APPLICATION SPECIFICATION	NONE		
TERMINALS APPLIED			
TE TERMINAL	WERI TERMINAL	TE TERMINAL	WERI TERMINAL
2113464-1	64500113722		

WIRE SIZE	CRIMP HEIGHT mm [INCH]	CRIMP HEIGHT REFERENCE SETTING
18 AWG	1.13 +/- 0.05 [.044 +/- .002]	6.8
20 AWG	0.98 +/- 0.05 [.038 +/- .002]	8.2
22 AWG	0.89 +/- 0.05 [.035 +/- .002]	9.2

- 1. RECOMMENDED SPARE PARTS
- 2. REFER TO SUPPLIED INSTRUCTION SHEET FOR CLEANING, LUBRICATION AND STORAGE OF APPLICATOR.
- 3. APPLY PART NUMBER 2-23419-6 LOCTITE TO THREADS OF ITEMS 242.
- 4. CRIMP HEIGHT REFERENCE SETTING WAS THE SETTING USED WHEN THE APPLICATOR WAS QUALIFIED AT THE FACTORY. ADJUSTMENT MAY BE NECESSARY WHEN RUNNING APPLICATOR IN THE FIELD.
- 5. UNLESS SPECIFIED OTHERWISE TORQUE VALUES SHALL BE USED PER DOCUMENT, 101-35000.

***WARNING**
ON INSTALLATION, SET WIRE DISC TO CRIMP HEIGHT REFERENCE SETTING FOR LARGEST WIRE SIZE. CRIMP HEIGHT REFERENCE SETTINGS GREATER THAN THE VALUE SHOWN MAY CAUSE DAMAGE TO THE CRIMP TOOLING, REFER TO THE INSTRUCTION SHEET FOR PROPER SETUP AND ADJUSTMENTS.

ATLANTIC VERSION
Shown on sheets 1 of 4 & 2 of 4
(Pacific version shown on sheets 3 of 4 & 4 of 4)

LOC	DIST	REV	DATE	BY	CHK	APP'D
A	66	A	30JUN2014	KH	UG	
		B	16NOV2020	LG	RR	

QTY	REF	REF	REF	REF	REF	DESCRIPTION	ITEM NO
-	1	-	1	-		2119641-1 FEED CAM, AIR FEED	248
-	1	1	1	1		2119082-3 CAM, SNAIL, INSULATION ADJUSTMENT	244
-	1	1	1	1		2079764-1 WASHER, WAVE SPRING, CREST-TO-CREST	243
-	1	1	1	1		2119083-1 RETAINER, INSULATION DIAL	242
-	1	1	1	1		7-18023-7 SCR, SKT HD CAP M3 X 4.0	241
-	-	1	-	1		2119580-1 MECHANICAL FEED ASSEMBLY	239
-	1	-	1	-		2844940-1 AIR FEED MODULE	238
-	REF	REF	REF	REF		994970-2 COUNTER, MAGNETIC	164
-	1	1	1	1		2844908-1 SCREW, LOCKING	99
-	1	1	1	1		2844907-1 POST, LOCKING	98
-	1	1	1	1		455888-5 SPACER, CRIMPER	82
-	1	1	1	1		5-547505-2 SPRING, COMPRESSION	77
-	1	1	1	1		854769-4 HOLDER, INS	74
-	1	1	1	1		1803607-3 DOCUMENTATION PACKAGE	71
-	1	1	1	1		2119791-5 DEPRESSOR, WIRE	70
-	1	1	1	1		2119740-1 TAG, IDENTIFICATION	67
-	2	2	2	2		2168078-1 SCREW, DRIVE, RH, RoHS, 2 x .188	66
-	1	1	1	1		2168083-2 SCR, SKT HD CAP, RoHS, M4 X 8.0	60
-	1	1	1	1		5-18022-5 SCR, HEX HD CAP, M4 X 6.0	59
-	1	1	1	1		21028-2 PIN, SLOTTED SPRING .062 X .250	58
-	1	1	1	1		1338685-1 PAWL, FEED	56
-	4	4	4	4		2168083-3 SCR, SKT HD CAP, RoHS, M4 X 12.0	54
-	2	2	2	2		1-2168083-0 SCR, SKT HD CAP, RoHS, M4 X 10	53
-	1	1	1	1		5018030-1 NUT, HEX, REG, RoHS, M3	52
-	1	1	1	1		811242-6 BUMPER, HOLD DOWN	51
-	1	1	1	1		690753-6 SPACER, TONKER	50
-	1	2	1	2		18023-9 SCR, SKT HD CAP M4 X 6.0	49
-	-	1	-	1		2119652-1 FEED CAM, PRE FEED	48
-	-	1	-	1		2119653-1 FEED CAM, POST FEED	47
-	1	1	1	1		1803583-9 APPLICATOR BASIC ASSEMBLY, SF	46
-	1	1	1	1		1803515-1 RAM ASSEMBLY, SF ATLANTIC	44
-	1	1	1	1		1803602-1 SCR, BHSC, RoHS (M8 X 25)	41
-	1	1	1	1		1752356-1 SUPPORT, TERMINAL	34
-	2	2	2	2		2079383-5 SCR, BHSC, RoHS (M4 X 20)	33
-	2	2	2	2		2-2844962-6 SPACER, CYLINDRICAL, STRIP GUIDE	30
-	1	1	1	1		2844992-1 ASSEMBLY, STRIP GUIDE	29
-	1	1	1	1		455888-3 SPACER, CRIMPER	28
-	1	1	1	1		1320928-2 STRIP GUIDE	24
-	1	1	1	1		2168083-2 SCR, SKT HD CAP, RoHS, M4 X 8.0	21
-	2	2	2	2		1-18028-2 WASHER, FLAT, REG M4	20
-	1	1	1	1		2119533-5 STRIPPER, SIDE FEED	19
-	1	1	1	1		2119806-1 INSERT, SHEAR	13
-	1	1	1	1		3-22280-3 SPRING, COMPRESSION	12
-	1	1	1	1		1-356885-4 STOP, SHEAR	11
-	1	1	1	1		2119805-1 SHEAR HOLDER, FRONT	10
-	1	1	1	1		1803095-6 FLOATING SHEAR, FRONT	9
-	1	2	2	1	1	2-1803057-5 ANVIL, COMBINATION	8
-	-	-	-	-		-	7
-	-	-	-	-		-	6
-	1	1	1	1		2119780-9 DEPRESSOR, SHEAR	5
-	1	1	1	1		238011-4 BLOCK, CRIMPER SPACER	4
-	1	2	2	1	1	4-2119784-0 CRIMPER, INSULATION O PREMIUM	3
-	-	-	-	-		-	2
-	1	2	2	1	1	3-456404-2 CRIMPER, WIRE PREMIUM	1
-	77	72	71	2	-1	PART NO	DESCRIPTION
-							ITEM NO

DIMENSIONS:		TOLERANCES UNLESS OTHERWISE SPECIFIED:		MATERIAL:		FINISH:	
mm	0 PLC ±	1 PLC ±	2 PLC ±	3 PLC ±	4 PLC ±	ANGLES	FINISH
MATERIAL:		FINISH:		WEIGHT:		SCALE:	
						1:2	

DATE: 22MAY2014	CHK: H. HUANG	DATE: 22MAY2014	CHK: L. ZHANG
DATE: 22MAY2014	APP'D: H. GUO	DATE: 22MAY2014	APP'D: H. GUO
PRODUCT SPEC:		APPLICATION SPEC:	
SIZE: A1		CAGE CODE: 00779	
DRAWING NO: 2266301		SHEET 1 OF 4	
Customer Accessible Production Drawing		REV B	

LOC	DIST	REV	DATE	BY	APP'D
A	66				

FEED TYPE MECHANICAL

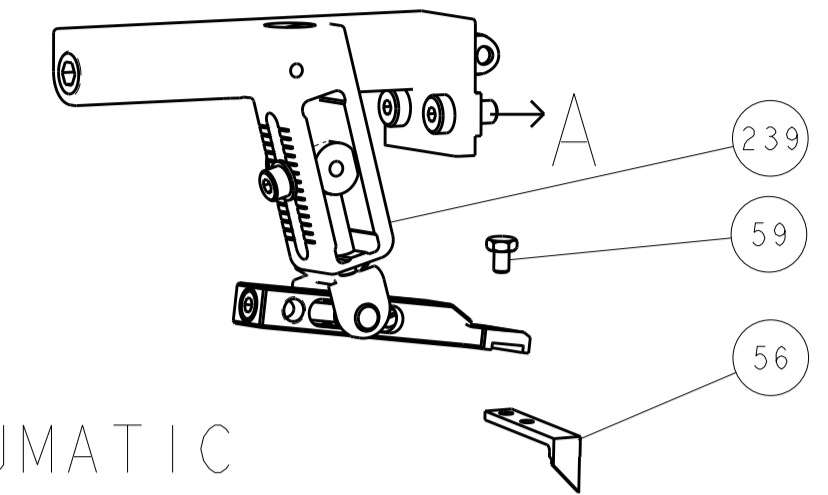

PNEUMATIC

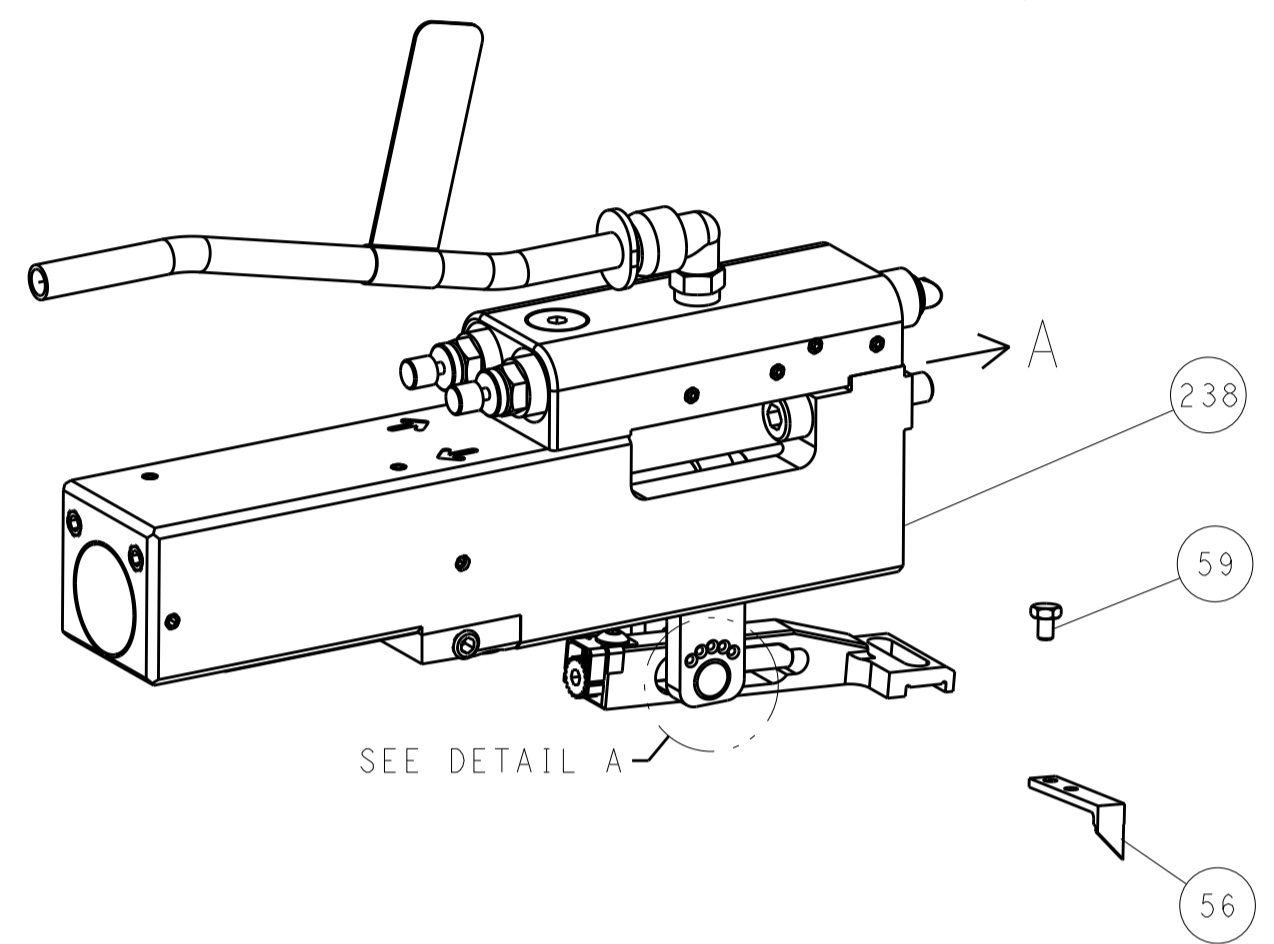

FEED SPRING SETTING POSITION (SHOWN FROM REAR SIDE)

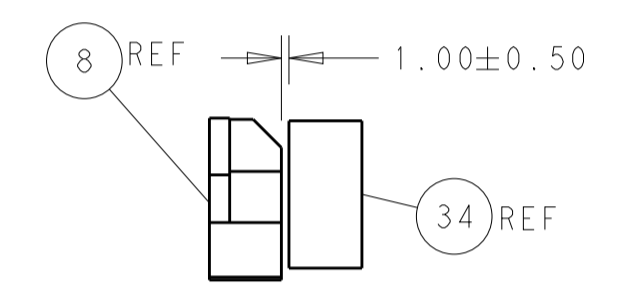
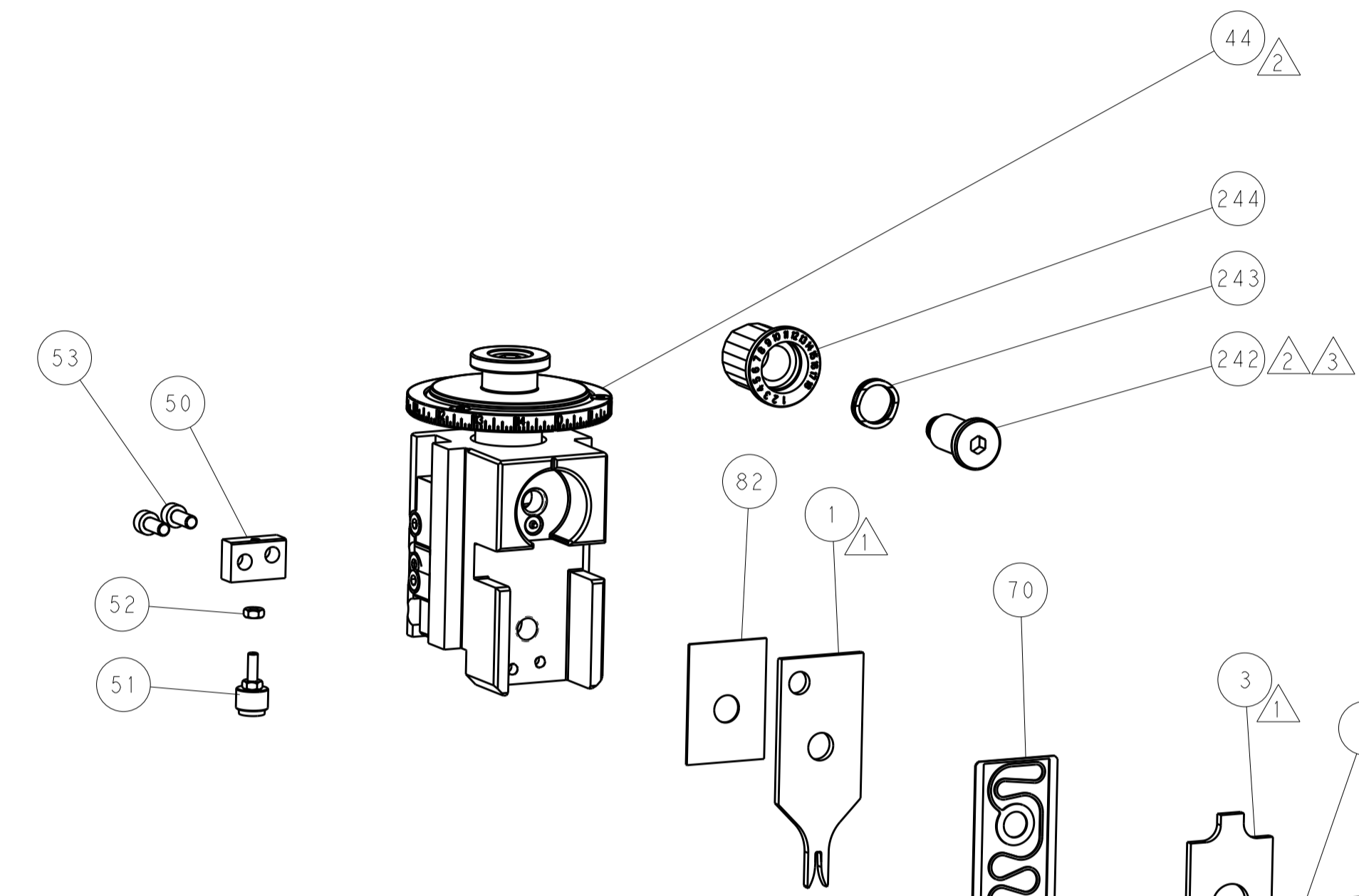
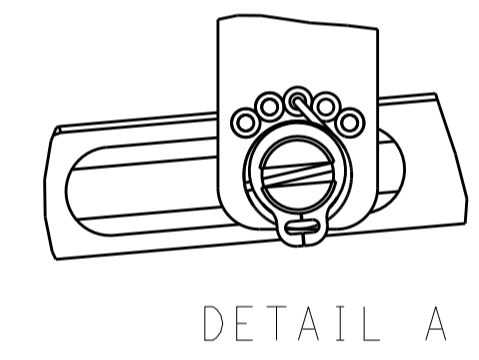

TERMINAL SUPPORT LOCATION

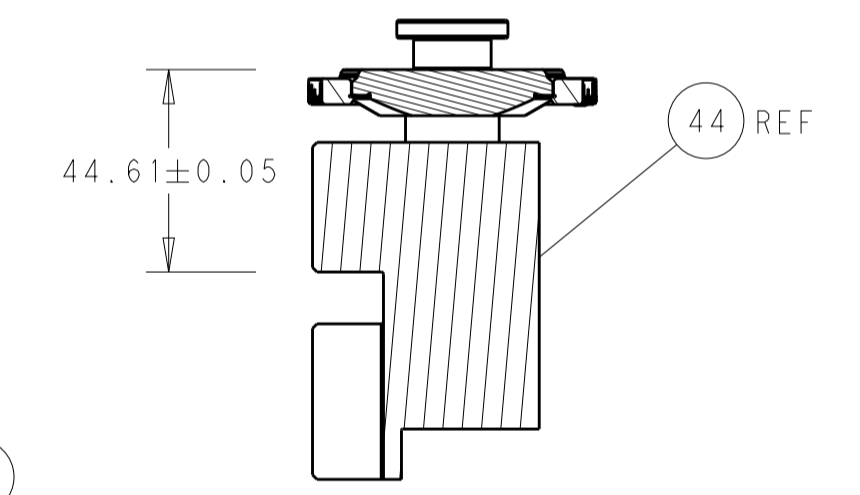

RAM SET-UP

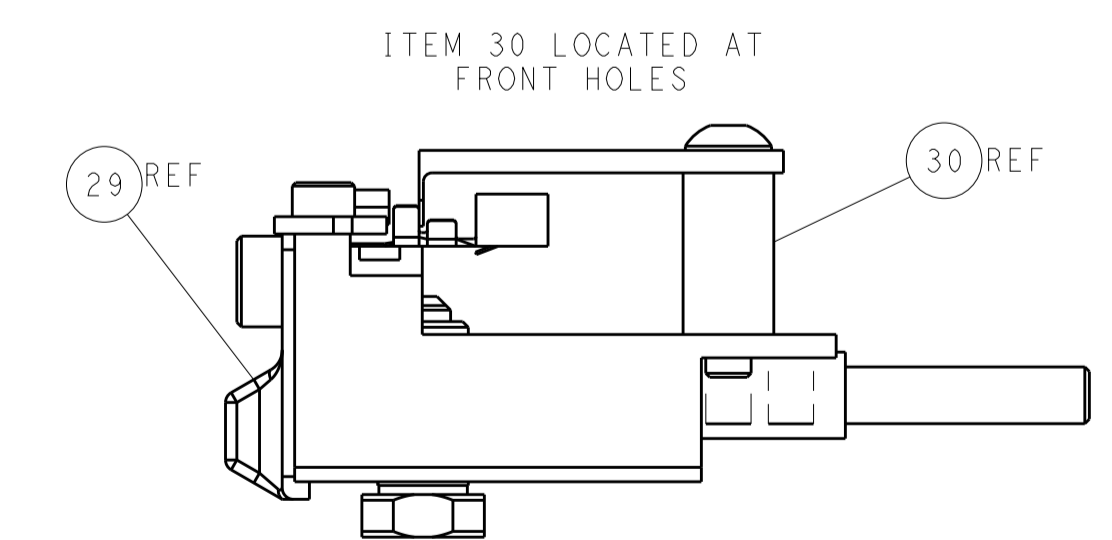
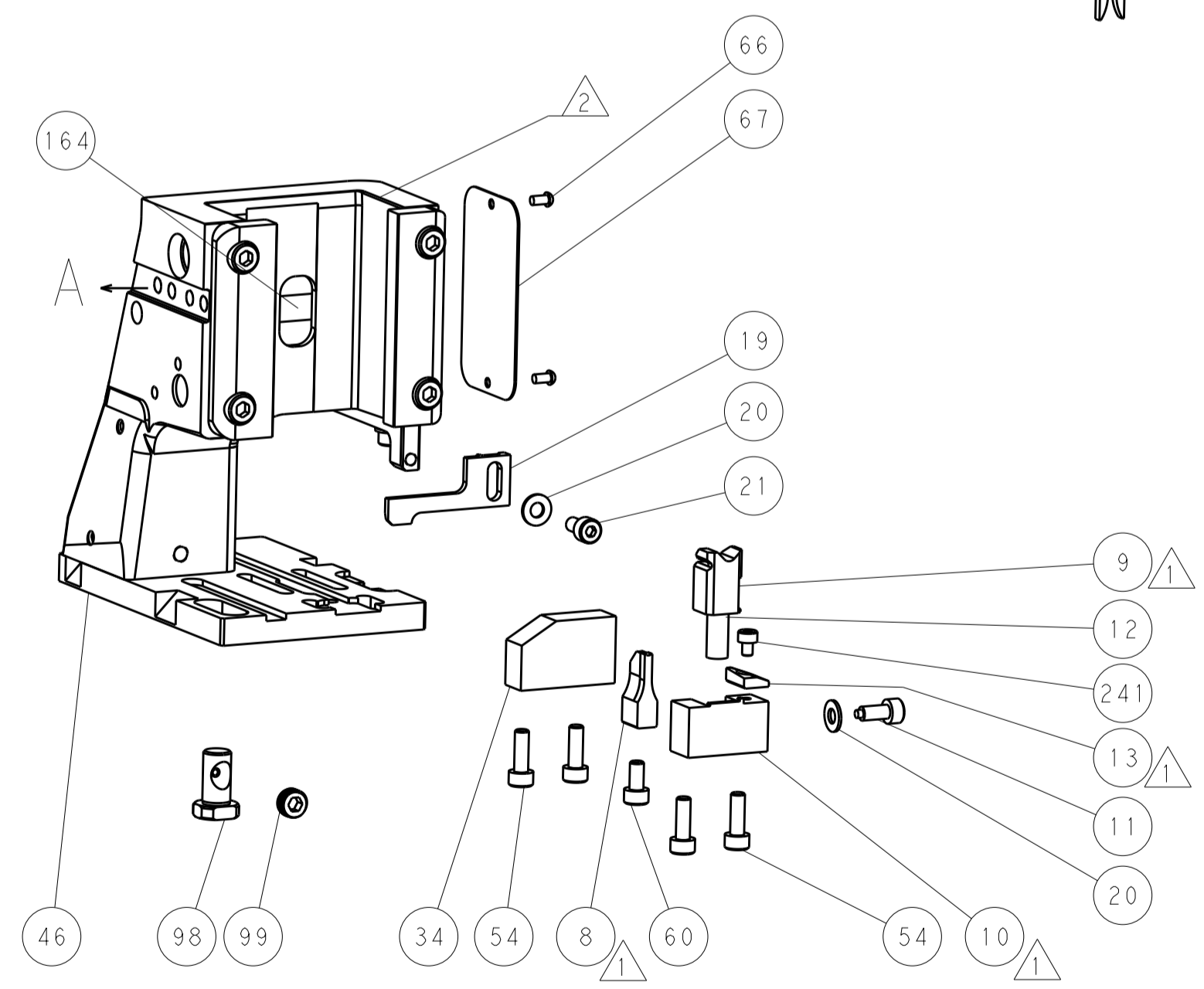
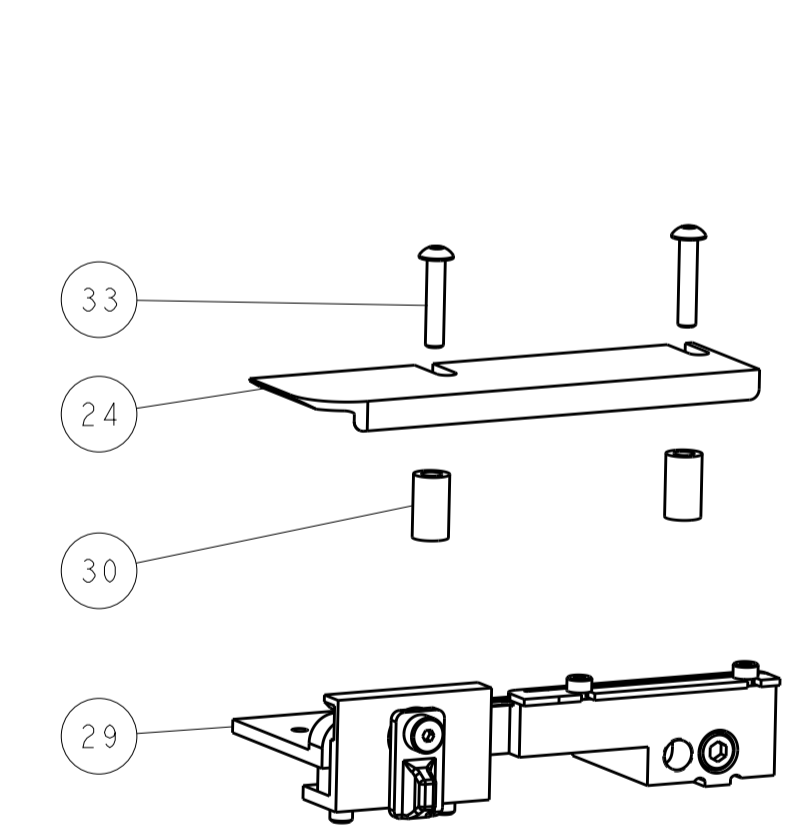

FEED TRACK POSITION GUIDE BY INSULATION BARREL

CAM POSITIONS



ATLANTIC VERSION
 Shown on sheets 1 of 4 & 2 of 4
 (Pacific version shown on sheets 3 of 4 & 4 of 4)

DIMENSIONS:		TOLERANCES UNLESS OTHERWISE SPECIFIED:		DWN H. HUANG 22MAY2014		TE Connectivity	
mm	0 PLC ±	1 PLC ±	2 PLC ±	3 PLC ±	4 PLC ±	CHK L. ZHANG 22MAY2014	Harrisburg, PA 17105-3608
	ANGLES ±			APVD JJ. GUO 22MAY2014		NAME Ocean Side Feed Applicator	
MATERIAL	FINISH			WEIGHT		SIZE CAGE CODE DRAWING NO. RESTRICTED TO	
				A1 00779 ©=2266301		Customer Accessible Production Drawing SCALE 1:2 SHEET 2 OF 4 REV B	

PART NUMBER	REVISION	DESCRIPTION	FEED TYPE
2-2266301-1	B	FINE CRIMP HEIGHT ADJUST	MECHANICAL
2-2266301-2	B	FINE CRIMP HEIGHT ADJUST	PNEUMATIC
7-2266301-7	A	CRIMP TOOLING KIT	-

PACIFIC VERSION TERMINATOR
INTERFACE ADAPTER



APPLICATOR DATA		
CRIMP	SIZE	TYPE
WIRE	1.78 mm [.070]	F
INSUL	2.54 mm [.100]	O

APPLICATOR INSTRUCTIONS
408-35042

TERMINAL DATA: WERI TERMINAL		TE CRIMP SPECIFICATION	
TERMINAL NAME: 3.96MM FEMALE TERMINAL			
WIRE STRIP LENGTH		INSULATION DIAMETER RANGE	
2.91-3.67 mm [.114-.144 IN]		Ø1.77-2.37 mm [.070-.093 IN]	
TERMINAL APPLICATION SPECIFICATION	NONE		
TERMINALS APPLIED			
TE TERMINAL	WERI TERMINAL	TE TERMINAL	WERI TERMINAL
2113464-1	64500113722		

WIRE SIZE	CRIMP HEIGHT mm [INCH]	CRIMP HEIGHT REFERENCE SETTING
18 AWG	1.13+/-0.05 [.044+/-0.002]	6.8
20 AWG	0.98+/-0.05 [.038+/-0.002]	8.2
22 AWG	0.89+/-0.05 [.035+/-0.002]	9.2

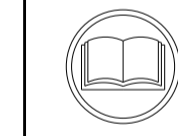

- 1 RECOMMENDED SPARE PARTS
- 2 REFER TO SUPPLIED INSTRUCTION SHEET FOR CLEANING, LUBRICATION AND STORAGE OF APPLICATOR.
- 3 APPLY PART NUMBER 2-23419-6 LOCTITE TO THREADS OF ITEMS 242.
- 4 CRIMP HEIGHT REFERENCE SETTING WAS THE SETTING USED WHEN THE APPLICATOR WAS QUALIFIED AT THE FACTORY. ADJUSTMENT MAY BE NECESSARY WHEN RUNNING APPLICATOR IN THE FIELD.
5. UNLESS SPECIFIED OTHERWISE TORQUE VALUES SHALL BE USED PER DOCUMENT, 101-35000.

***WARNING**
ON INSTALLATION, SET WIRE DISC TO CRIMP HEIGHT REFERENCE SETTING FOR LARGEST WIRE SIZE. CRIMP HEIGHT REFERENCE SETTINGS GREATER THAN THE VALUE SHOWN MAY CAUSE DAMAGE TO THE CRIMP TOOLING, REFER TO THE INSTRUCTION SHEET FOR PROPER SETUP AND ADJUSTMENTS.

PACIFIC VERSION
Shown on sheets 3 of 4 & 4 of 4
(Atlantic version shown on sheets 1 of 4 & 2 of 4)

LOC	DIST	REV	DATE	BY	APPV
A	66				

REVISIONS					
REV	DATE	DESCRIPTION	DATE	BY	APPV
-	-	SEE SHEET 1	-	-	-
-	1	1	2119082-3	CAM, SNAIL, INSULATION ADJUSTMENT	244
-	1	1	2079764-1	WASHER, WAVE SPRING, CREST-TO-CREST	243
-	1	1	2119083-1	RETAINER, INSULATION DIAL	242
-	1	1	7-18023-7	SCR, SKT HD CAP M3 X 4.0	241
-	-	1	2119580-1	MECHANICAL FEED ASSEMBLY	239
-	1	-	2844940-1	AIR FEED MODULE	238
-	REF	REF	994970-2	COUNTER, MAGNETIC	164
-	1	-	2119641-2	FEED CAM, AIR FEED	151
-	1	1	2168083-8	SCR, SKT HD CAP, RoHS, M4 X 16	144
-	4	4	2168083-9	SCR, SKT HD CAP, RoHS, M4 X 20	143
-	-	1	2119653-2	FEED CAM, POST FEED	142
-	1	1	1-1803583-0	APPLICATOR BASIC ASSEMBLY, SF	141
-	1	1	1803516-1	RAM ASSEMBLY, SF PACIFIC	140
-	1	1	2844908-1	SCREW, LOCKING	99
-	1	1	2844907-1	POST, LOCKING	98
-	1	1	455888-5	SPACER, CRIMPER	82
-	1	1	5-547505-2	SPRING, COMPRESSION	77
-	1	1	854769-4	HOLDER, INS	74
-	1	1	1803607-3	DOCUMENTATION PACKAGE	71
-	1	1	2119791-5	DEPRESSOR, WIRE	70
-	1	1	2119740-1	TAG IDENTIFICATION	67
-	2	2	2168078-1	SCREW, DRIVE, RH, RoHS, 2 x .188	66
-	1	1	5-18022-5	SCR, HEX HD CAP, M4 X 6.0	59
-	1	1	21028-2	PIN, SLOTTED SPRING .062 X .250	58
-	1	1	1338685-1	PAWL, FEED	56
-	2	2	1-2168083-0	SCR, SKT HD CAP, RoHS, M4 X 10	53
-	1	1	5018030-1	NUT, HEX, REG, RoHS, M3	52
-	1	1	811242-6	BUMPER, HOLD DOWN	51
-	1	1	690753-6	SPACER, TONKER	50
-	1	2	18023-9	SCR, SKT HD CAP M4 X 6.0	49
-	-	1	2119652-1	FEED CAM, PRE FEED	48
-	1	1	1803602-1	SCR, BHSC, RoHS (M8 X 25)	41
-	1	1	1752356-1	SUPPORT, TERMINAL	34
-	2	2	2079383-5	SCR, BHSC, RoHS (M4 X 20)	33
-	2	2	2-2844962-6	SPACER, CYLINDRICAL, STRIP GUIDE	30
-	1	1	2844992-1	ASSEMBLY, STRIP GUIDE	29
-	1	1	455888-3	SPACER, CRIMPER	28
-	1	1	1320928-2	STRIP GUIDE	24
-	1	1	2168083-2	SCR, SKT HD CAP, RoHS, M4 X 8.0	21
-	2	2	1-18028-2	WASHER, FLAT, REG M4	20
-	1	1	2119533-5	STRIPPER, SIDE FEED	19
-	1	1	2119806-1	INSERT, SHEAR	13
-	1	1	3-22280-3	SPRING, COMPRESSION	12
-	1	1	1-356885-4	STOP, SHEAR	11
-	1	1	2119805-1	SHEAR HOLDER, FRONT	10
-	1	1	1803095-6	FLOATING SHEAR, FRONT	9
1	1	1	2-1803057-5	ANVIL, COMBINATION	8
-	-	-	-	-	7
-	-	-	-	-	6
-	1	1	2119780-9	DEPRESSOR, SHEAR	5
-	1	1	238011-4	BLOCK, CRIMPER SPACER	4
-	-	-	-	-	2
1	1	1	4-2119784-0	CRIMPER, INSULATION O PREMIUM	3
-	-	-	-	-	2
1	1	1	3-456404-2	CRIMPER, WIRE PREMIUM	1

DIMENSIONS:		TOLERANCES UNLESS OTHERWISE SPECIFIED:		OTHERWISE SPECIFIED:	
mm	0 PLC	±			
	1 PLC	±			
	2 PLC	±			
	3 PLC	±			
	4 PLC	±			
	ANGLES	±			
	FINISH	±			

OWN	H. HUANG	Z2MAY2014
CHK	L. ZHANG	Z2MAY2014
APPV	J. GUO	Z2MAY2014
NAME	Ocean Side Feed Applicator	
SIZE	CAGE CODE	DRAWING NO
A1	00779	2266301
Customer Accessible Production Drawing		
SCALE	1:2	SHEET 3 OF 4
REV	B	

LOC		DIST		REVISIONS			
A	66	P	LTM	DESCRIPTION	DATE	DWN	APVD
		-		SEE SHEET 1			

FEED TYPE MECHANICAL

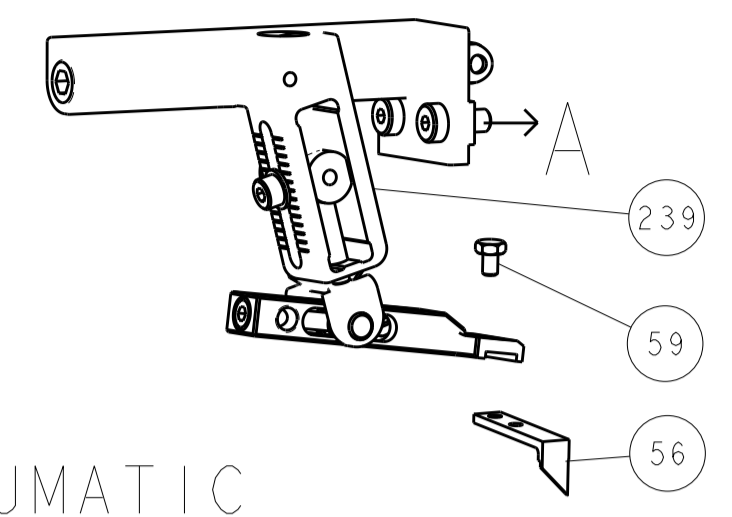

PNEUMATIC

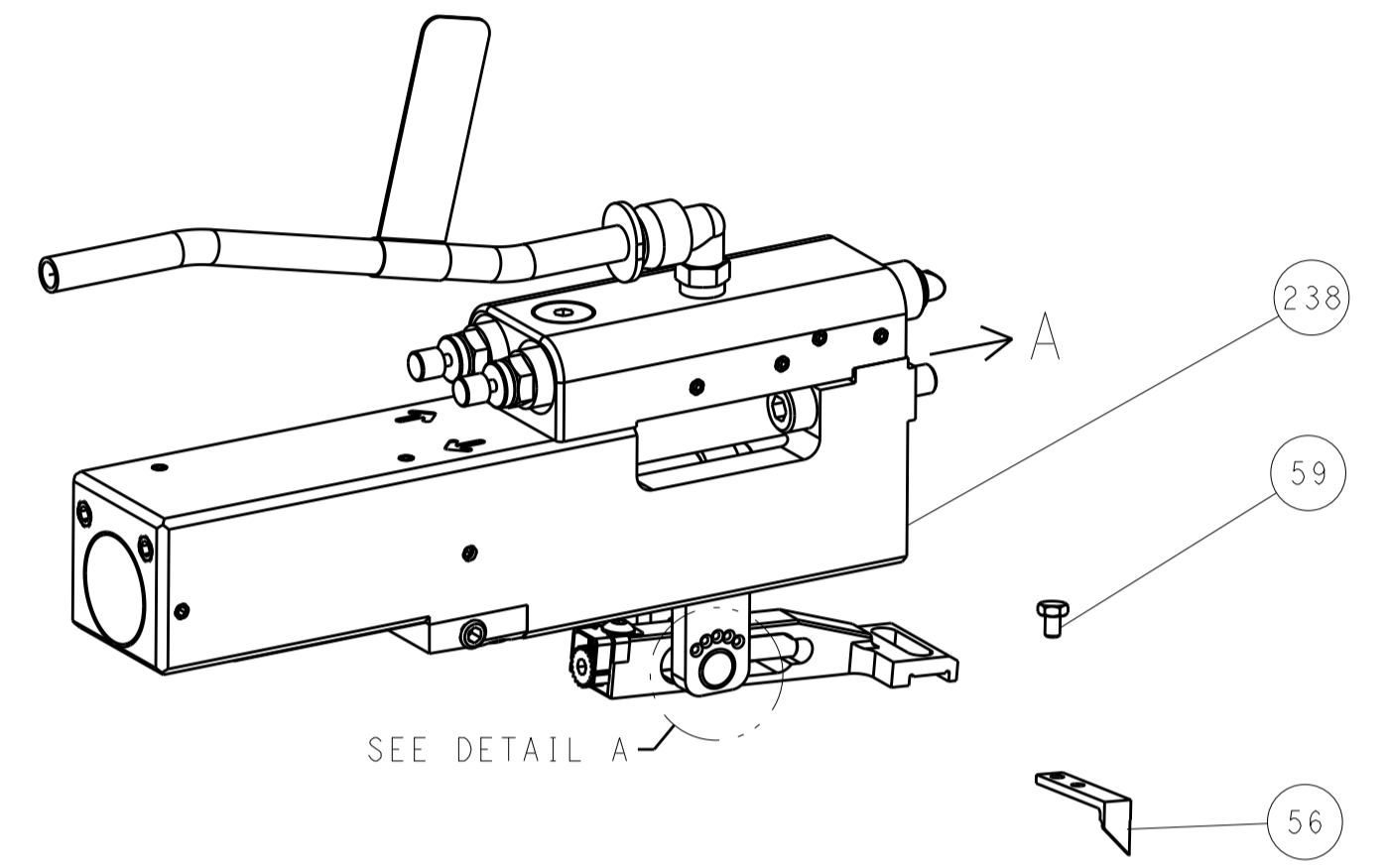

FEED SPRING SETTING POSITION (SHOWN FROM REAR SIDE)

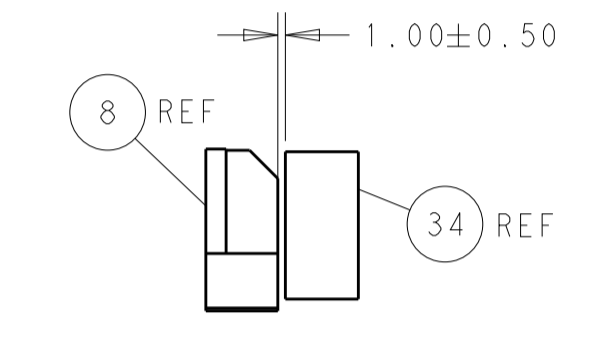
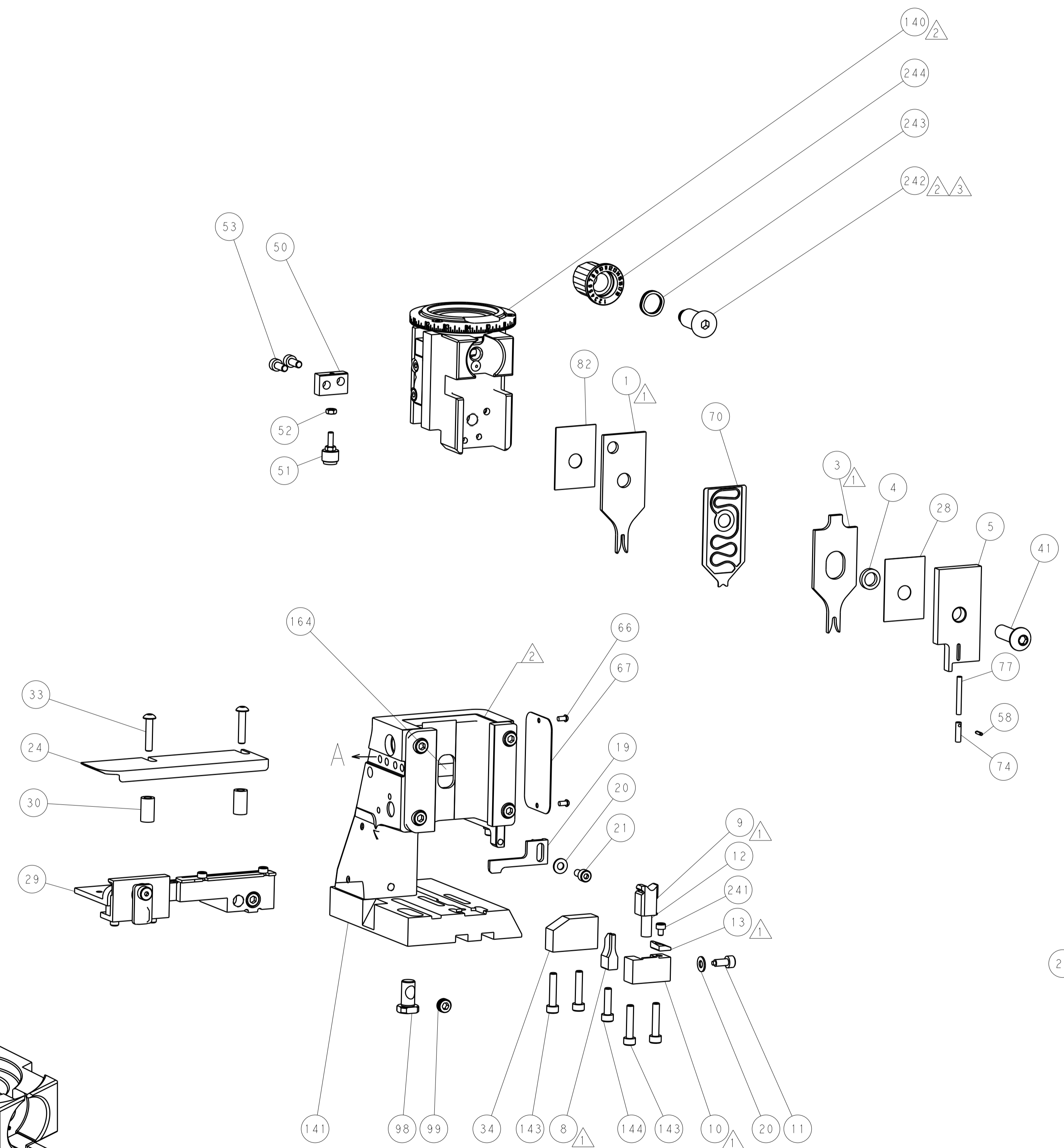
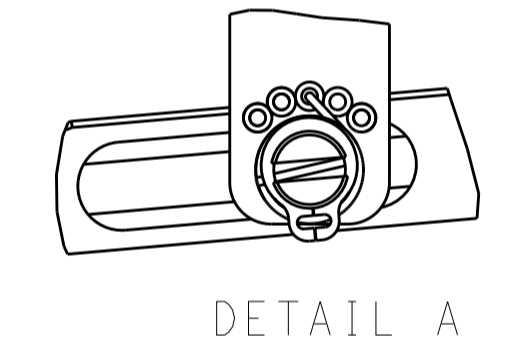

TERMINAL SUPPORT LOCATION

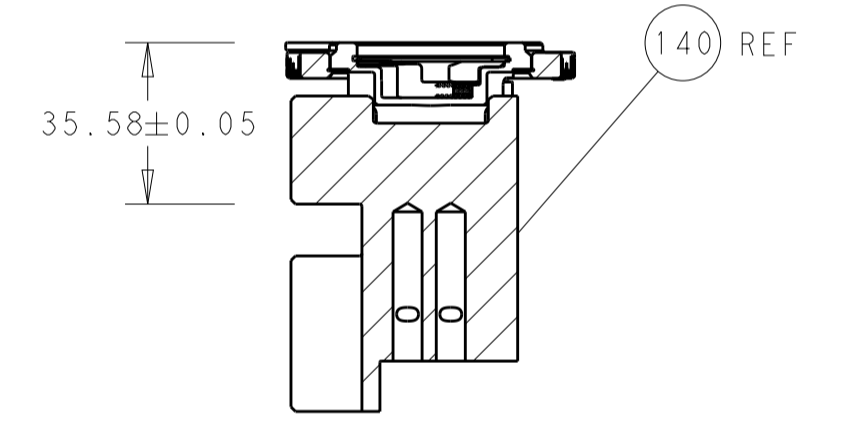

RAM SET-UP

ITEM 30 LOCATED AT FRONT HOLES

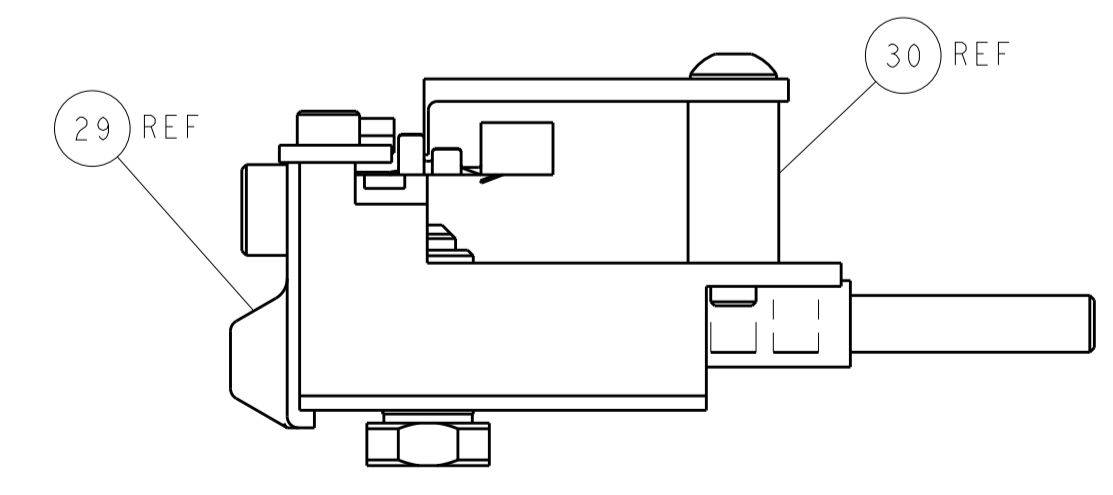

FEED TRACK POSITION GUIDE BY INSULATION BARREL

CAM POSITIONS

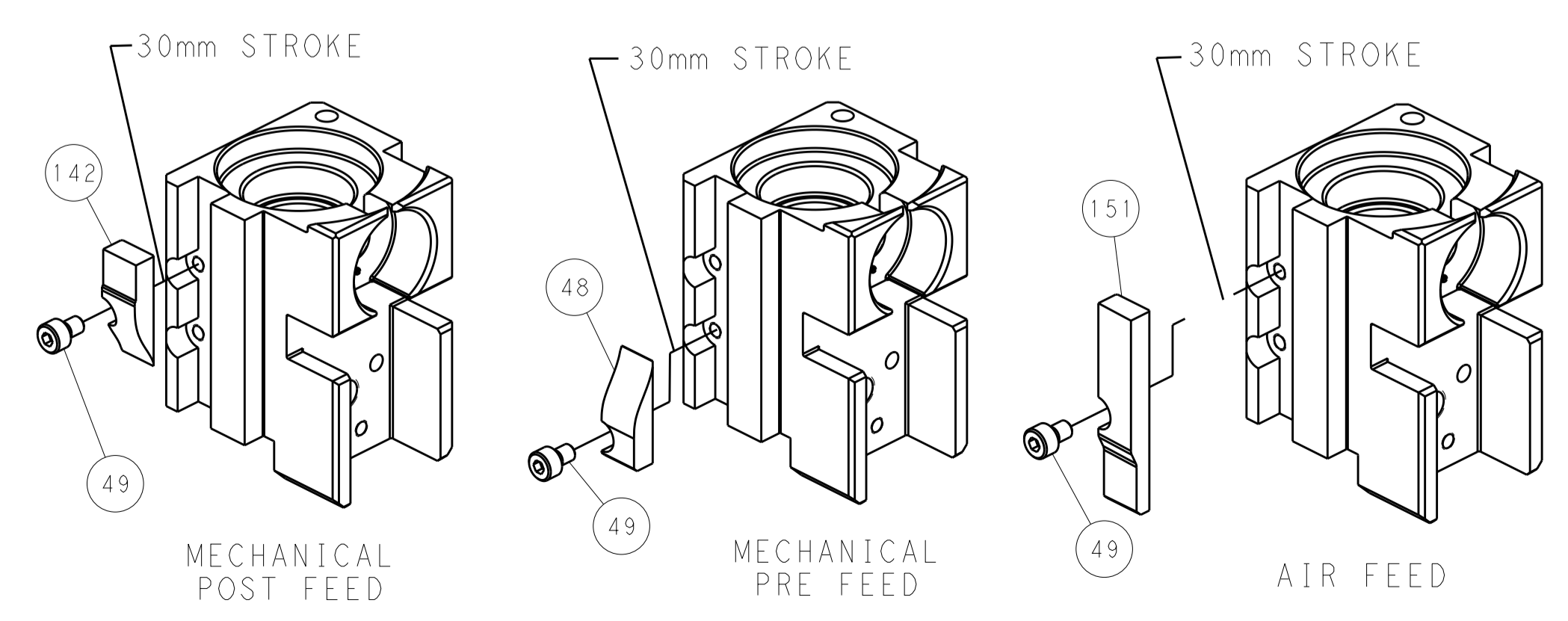

PACIFIC VERSION
 Shown on sheets 3 of 4 & 4 of 4
 (Atlantic version shown on sheets 1 of 4 & 2 of 4)

<small>THIS DRAWING IS UNPUBLISHED. RELEASED FOR PUBLICATION. IT IS THE PROPERTY OF TYCO ELECTRONICS CORPORATION. IT IS SUBJECT TO CHANGE AND WITHOUT WARRANTY OF ANY KIND. THE USER SHALL BE RESPONSIBLE FOR THE LATEST REVISION.</small>		DWN: H. HUANG 22MAY2014 CHK: L. ZHANG 22MAY2014 APVD: H. GUO 22MAY2014	NAME: TE Connectivity Harrisburg, PA 17105-3608
DIMENSIONS: mm TOLERANCES UNLESS OTHERWISE SPECIFIED: 0 PLC ± 1 PLC ± 2 PLC ± 3 PLC ± 4 PLC ± ANGLES ± MATERIAL: - FINISH: -		PRODUCT SPEC: APPLICATION SPEC: WEIGHT: - SCALE: 1:2	SIZE: A1 CAGE CODE: 00779 DRAWING NO: 2266301 SHEET 4 OF 4 REV B