

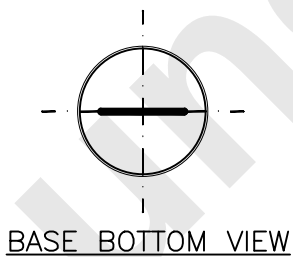

PART NO.	BASE TYPE	DESIGN VOLTS	DESIGN AMPS	MSCD	FILAMENT TYPE	AVERAGE LIFE HOURS	REVISIONS			
							REV #	DESCRIPTION	DATE	APPROVED
212-2	MINIATURE END CAPS	13.5V	0.74±10%	6±20%	C-8	2000	1	ISSUED	06/10/2013	D.C.
							2	ADDED BASE VIEWS	04/05/2016	R.M.

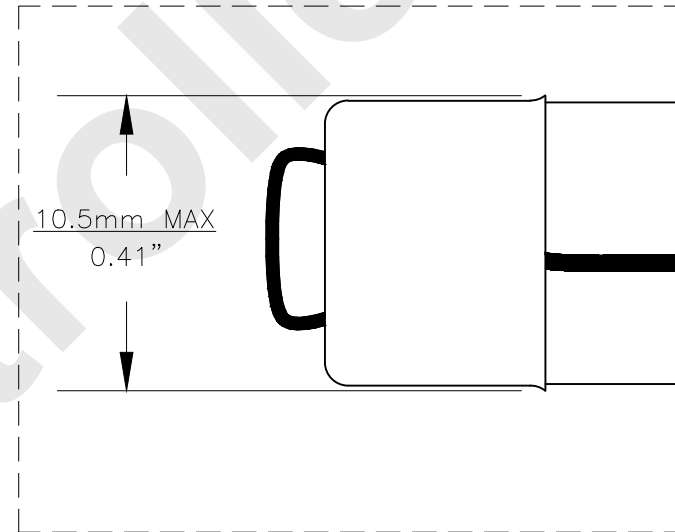
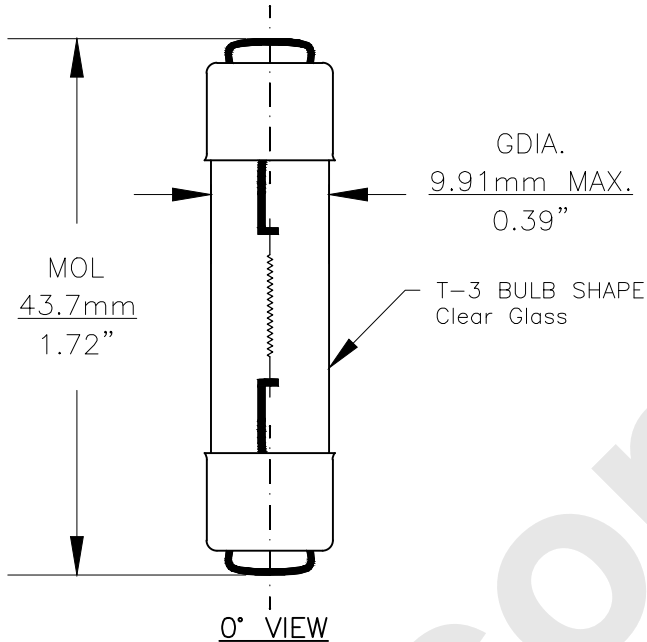

Note: Made according to SAE specifications

UNLESS OTHERWISE SPECIFIED: DIMENSIONS ARE IN INCHES TOLERANCES		CEC INDUSTRIES LTD			
DECIMALS	ANGULAR	599 BOND STREET		LINCOLNSHIRE, IL 60069	
.XX ± .05	± 0.5°	TITLE LIGHT BULB NO. 212-2			
.XXX ± .010		CHECKED	DATE 06/10/2013	SIZE A	FSCM NO. 212-2
FRACTIONAL ± 1/64		DESIGN	SCALE	PLOT SCALE	REV 2
		MATERIAL	FILE 212-2.pdf	SHEET 1 OF 1	DRAWING NOT TO SCALE