

THIS DOCUMENT IS THE PROPERTY OF KEYSTONE ELECTRONICS CORP. AND SHALL NOT BE REPRODUCED, DISTRIBUTED OR USED AS A BASIS FOR MANUFACTURE WITHOUT PRIOR WRITTEN PERMISSION FROM KEYSTONE ELECTRONICS CORP.

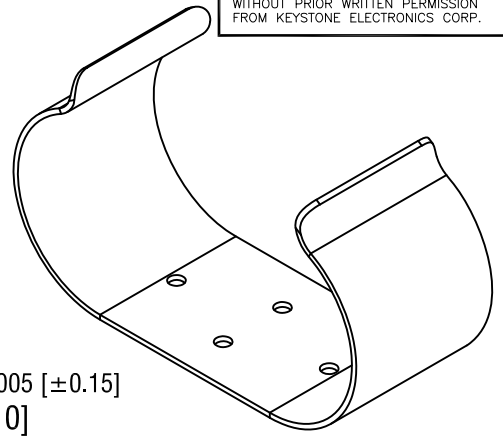

±.005 [±0.15]  
 .098 [2.49] DIA. HOLE  
 (4) PLS

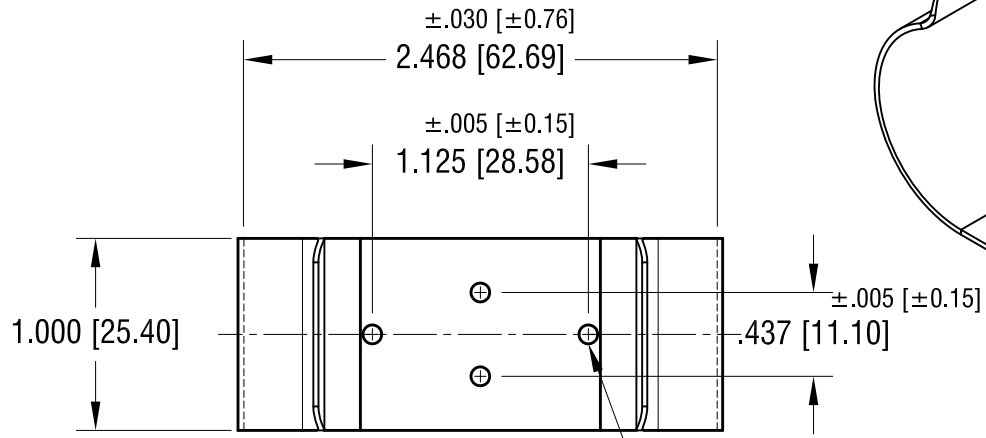
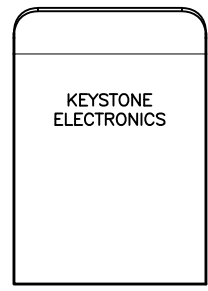
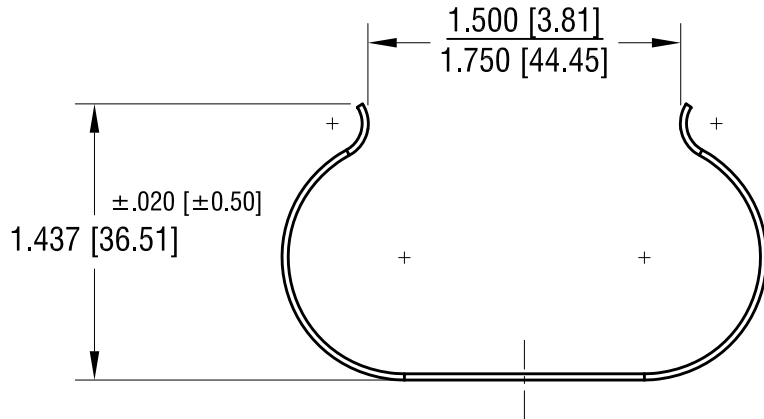

<b>KEYSTONE ELECTRONICS CORP.</b>			
www.keyelco.com • NEW HYDE PARK NY 11040 • Tel (516)328-7500			
PART NAME			
COMPONENT CLIP, (2) "D" CELL			
MATERIAL			
.032 [0.81] TH'K ALUMINUM 2024-T3			
FINISH		DRN BY	DATE
NONE		BOONE	4.07.00
		APP'D	SCALE
		RH	1X
DATE	DESCRIPTION	REV.	TOLERANCES INCH [MM]
9.21.00	CHANGE AS PER ECN 00-102	A	DECIMAL ±.010 [±0.25]
			ANGULAR ± 1°
			UNLESS OTHERWISE SPECIFIED
			CODE
			DWG NO.
			98

DATE	DESCRIPTION	REV.
9.21.00	CHANGE AS PER ECN 00-102	A