

## STWIN SensorTile Wireless Industrial Node development kit and reference design for industrial IoT applications

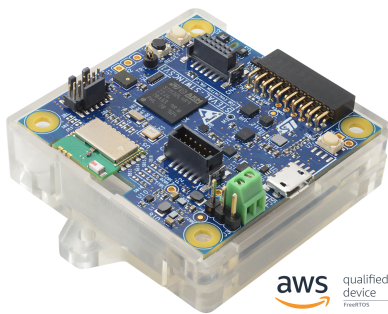

### Features

- Multi-sensing wireless platform implementing vibration monitoring and ultrasound detection
- Built around STWIN core system board with processing, sensing, connectivity and expansion capabilities
- Ultra-low-power ARM Cortex-M4 MCU at 120 MHz with FPU, 2048 kbytes Flash memory (STM32L4R9)
- Micro SD Card slot for standalone data logging applications
- Wireless BLE4.2 (on-board) and Wi-Fi (with STEVAL-STWINWV1 expansion board), and wired RS485 and USB OTG connectivity
- Option to implement Authentication and Brand protection secure solution with STSAFE-A110 (footprint)
- Wide range of industrial IoT sensors:
  - ultra-wide bandwidth (up to 6 kHz), low-noise, 3-axis digital vibration sensor (IIS3DWB)
  - 3D accelerometer + 3D Gyro iNEMO inertial measurement unit (ISM330DHCX) with machine learning core
  - ultra-low-power high performance MEMS motion sensor (IIS2DH)
  - ultra-low-power 3-axis magnetometer (IIS2MDC)
  - digital absolute pressure sensor (LPS22HH)
  - relative humidity and temperature sensor (HTS221)
  - low-voltage digital local temperature sensor (STTS751)
  - industrial grade digital MEMS microphone (IMP34DT05)
  - wideband analog MEMS microphone (MP23ABS1)
- Modular architecture, expandable via on-board connectors:
  - STMOD+ and 40-pin flex general purpose expansions
  - 12-pin male plug for connectivity expansions
  - 12-pin female plug for sensing expansions
- Other kit components:
  - Li-Po battery 480 mAh
  - STLINK-V3MINI debugger with programming cable
  - Plastic box

Product summary	
STWIN SensorTile Wireless Industrial Node development kit	STEVAL-STWINKT1
Firmware for STEVAL-STWINKT1 evaluation kit	STSW-STWINKT01
Ultra-low-power ARM Cortex-M4 MCU with FPU	STM32L4R9ZIJ6
3D Accelerometer + 3D Gyro iNEMO Inertial measurement unit (IMU) with machine learning core	ISM330DHCX
Ultra-wide bandwidth (up to 6 kHz), low-noise, 3-axis digital vibration sensor	IIS3DWB
Firmware debug and update interface	STLINK-V3MINI debugger
Applications	IoT for Smart industry

### Description

The STWIN SensorTile wireless industrial node (STEVAL-STWINKT1) is a development kit and reference design that simplifies prototyping and testing of advanced industrial IoT applications such as condition monitoring and predictive maintenance.

The kit features a core system board with a range of embedded industrial-grade sensors and an ultra-low-power microcontroller for vibration analysis of 9-DoF motion sensing data across a wide range of vibration frequencies, including very high frequency audio and ultrasound spectra, and high precision local temperature and environmental monitoring.

Product summary	
	Condition Monitoring and Predictive Maintenance Industrial Sensors

The development kit is complemented with a rich set of software packages and optimized firmware libraries, as well as a cloud dashboard application, all provided to help speed up design cycles for end-to-end solutions.

The kit supports BLE wireless connectivity through an on-board module, and Wi-Fi connectivity through a special plugin expansion board ([STEVAL-STWINWFV1](#)). Wired connectivity is also supported via an on-board RS485 transceiver. The core system board also includes an STMod+ connector for compatible, low cost, small form factor daughter boards associated with the STM32 family, such as the LTE Cell pack.

Apart from the core system board, the kit is provided complete with a 480 mAh Li-Po battery, an [STLINK-V3MINI](#) debugger and a plastic box.

# 1 Application overview

Predictive maintenance applications collect and process data from a wide variety of sensors in order to identify potential failures in machinery before they happen. A principal requirement of such applications is that the condition monitoring equipment is placed very close to relevant machine componentry for the data to be reliable, which is why the STWIN node is designed to be small but robust, self-powered and capable of wireless communication.

Another application issue is the high volumes of preferably real-time data processing involved, which can overwhelm centralized monitoring and control systems, and corresponding communication networks. Distributed (or decentralized) computing architectures represent a valid solution to this problem by performing data pre-processing and analytical operations directly on the node. The STWIN kit supports and can demonstrate this concept through sample applications in the firmware package running on the STM32L4+ ultra-low-power microcontroller embedded on the core system board.

Figure 1. STWIN core system block diagram

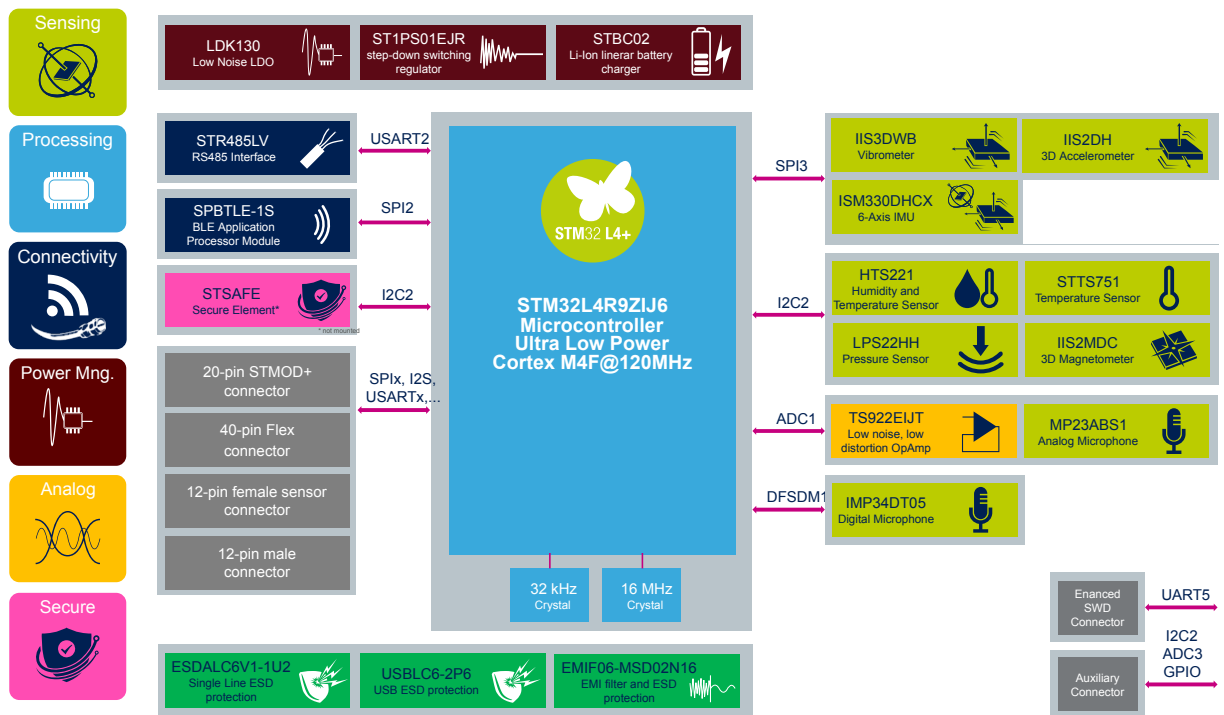

Finally, the actual sensing equipment can be subject to a very wide range of low frequency (imbalance or misalignment), medium frequency (worn gears or bearings) and high frequency (worn cooling fan bearings) vibrations, which is why our node carries several high performance accelerometers, IMUs and magnetometers, capable of detecting movement along 9 axes to a very high degree of sensitivity. For very high frequencies in the order of tens of kilohertz, vibration analysis is covered by sound and ultrasound applications based on data coming from a digital microphone and a high performance analog microphone, respectively.

## RELATED LINKS

[Visit the ST Condition Monitoring / Predictive Maintenance application page for more information on relevant ST applications and solutions](#)

## 2 Schematic diagrams

Figure 2. STEVAL-STWINKT1 schematic - power

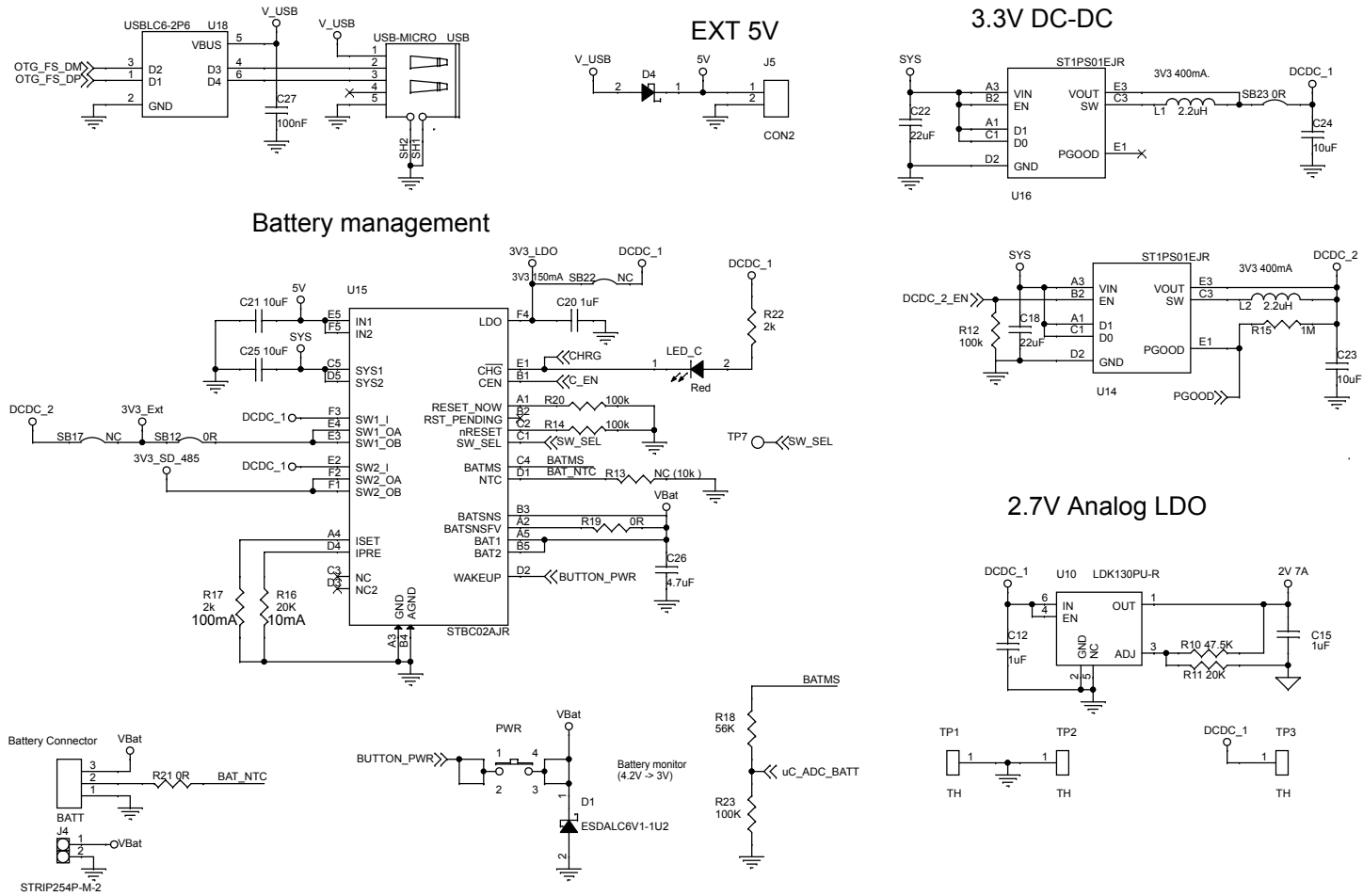

Figure 3. STEVAL-STWINKT1 schematic - connectors

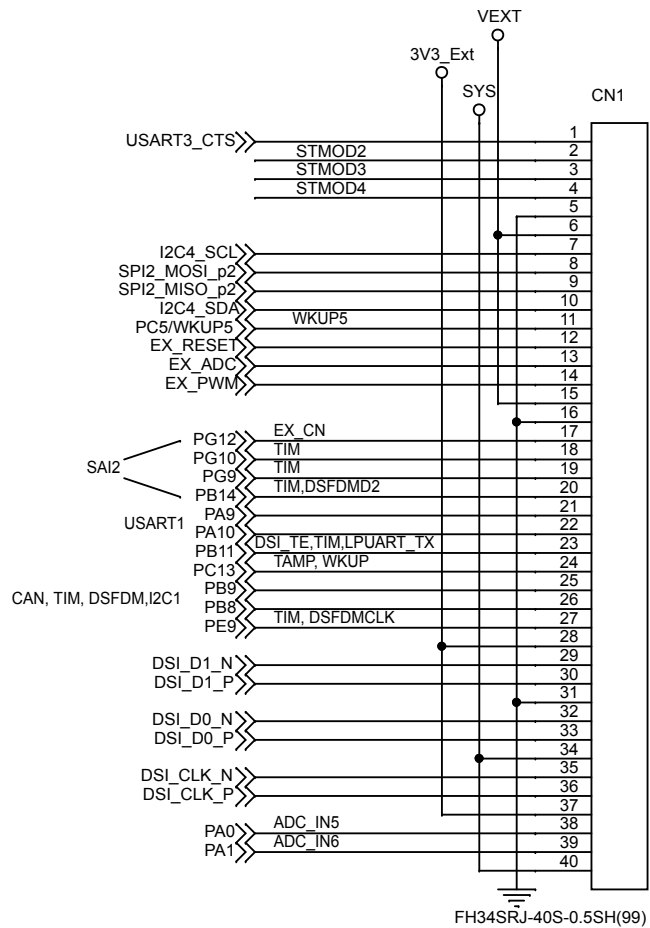
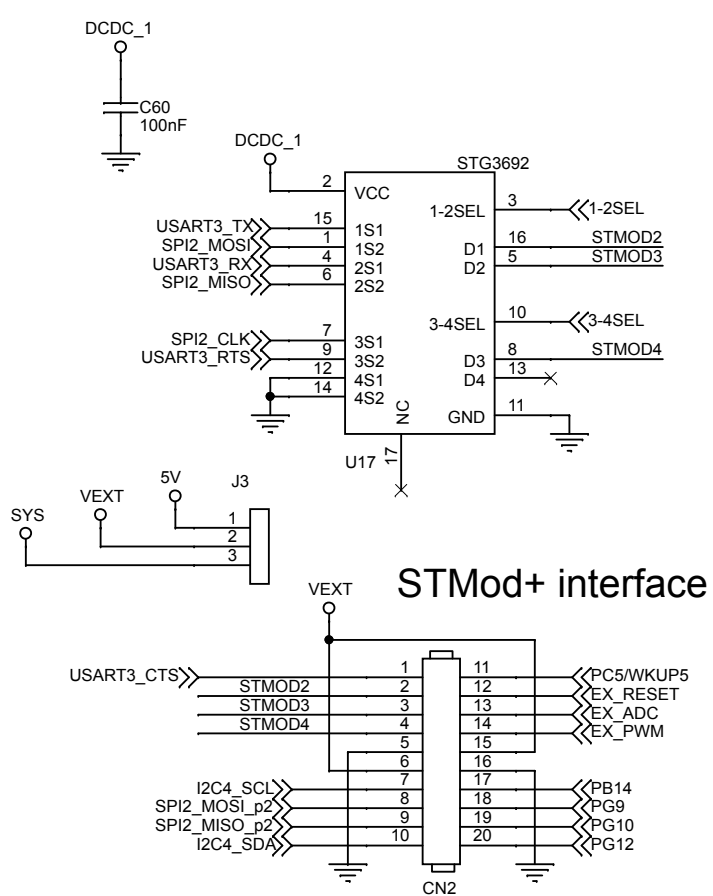
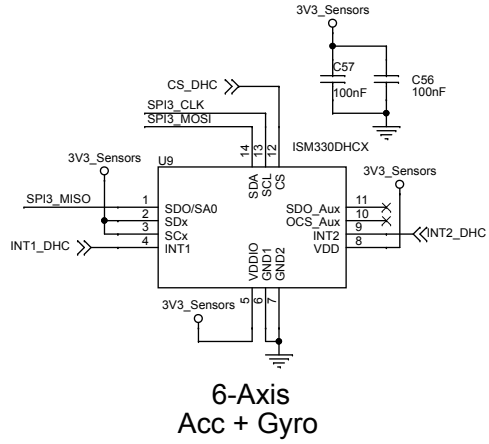
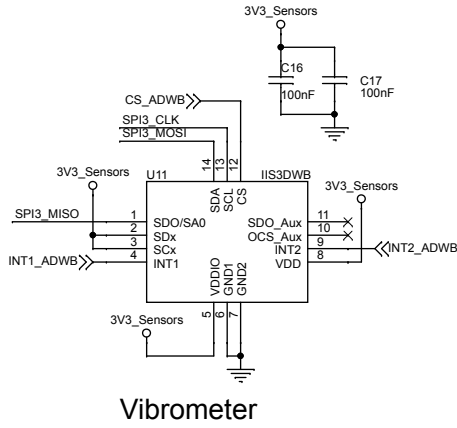

Figure 4. STEVAL-STWINKT1 schematic - sensors



6-Axis Acc + Gyro



Vibrometer

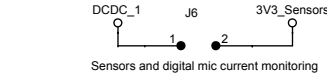

Sensors and digital mic current monitoring

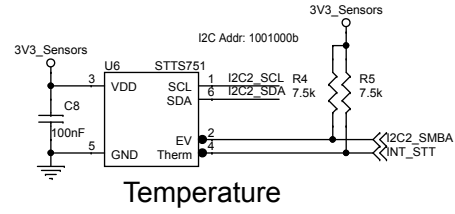
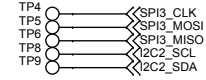

Temperature

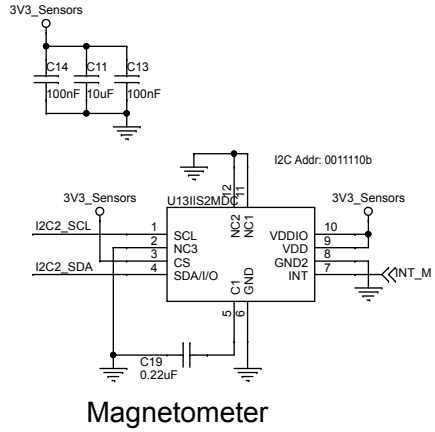

Magnetometer

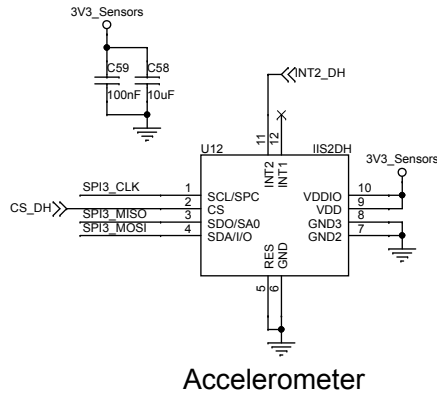

Accelerometer

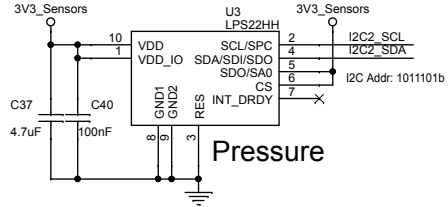

Pressure

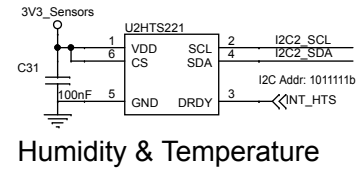

Humidity & Temperature



Figure 5. STEVAL-STWINKT1 schematic - MCU

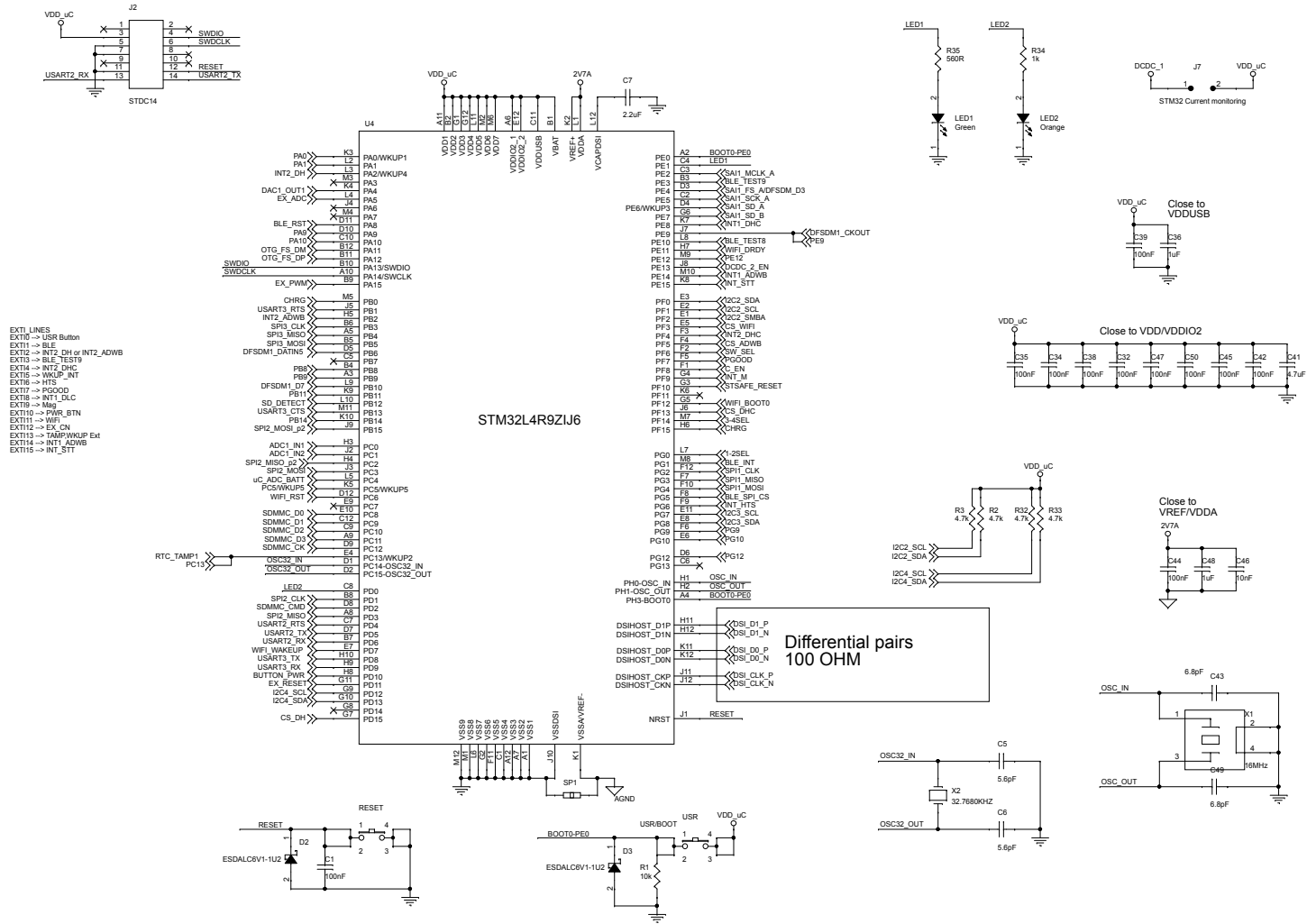

Figure 6. STEVAL-STWINKT1 schematic - audio, RS485, SD card

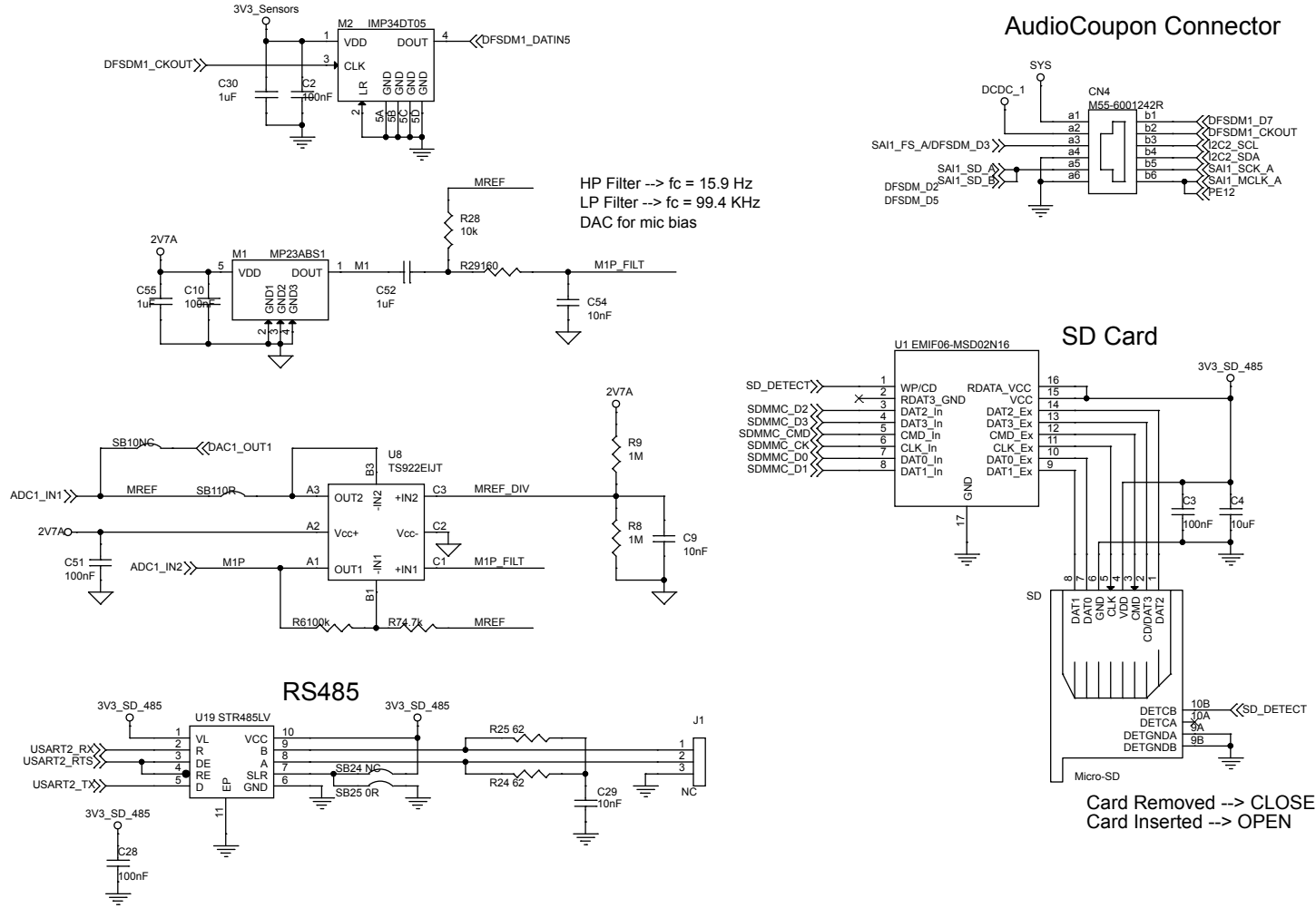
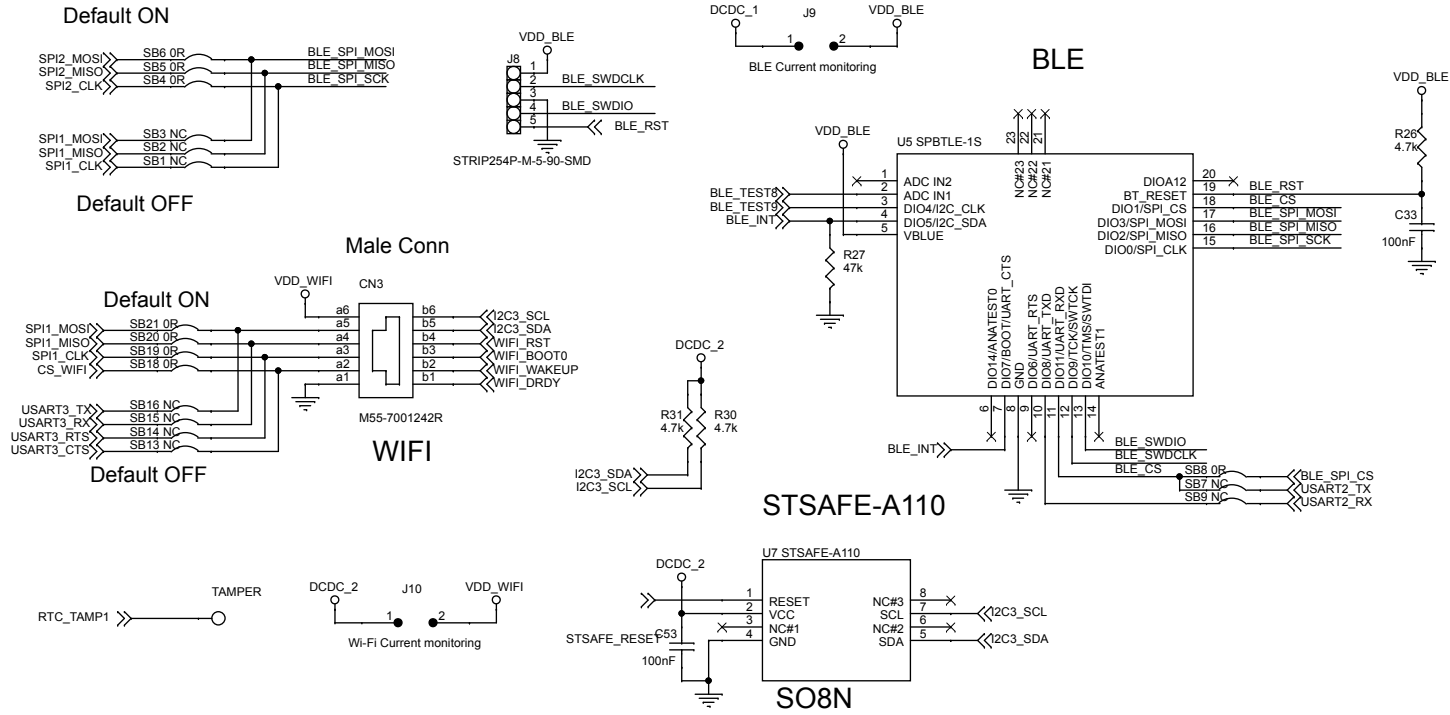



Figure 7. STEVAL-STWINKT1 schematic - BLE, Wi-Fi, STSAFE-A110



## Revision history

**Table 1. Document revision history**

Date	Version	Changes
29-Jul-2019	1	Initial release.
03-Feb-2020	2	Updated cover page features and product summary table.
10-Mar-2020	3	Updated cover page features.
28-May-2020	4	Updated cover page image, features and <a href="#">Figure 7. STEVAL-STWINKT1 schematic - BLE, Wi-Fi, STSAFE-A110</a> .

**IMPORTANT NOTICE – PLEASE READ CAREFULLY**

STMicroelectronics NV and its subsidiaries (“ST”) reserve the right to make changes, corrections, enhancements, modifications, and improvements to ST products and/or to this document at any time without notice. Purchasers should obtain the latest relevant information on ST products before placing orders. ST products are sold pursuant to ST’s terms and conditions of sale in place at the time of order acknowledgement.

Purchasers are solely responsible for the choice, selection, and use of ST products and ST assumes no liability for application assistance or the design of Purchasers’ products.

No license, express or implied, to any intellectual property right is granted by ST herein.

Resale of ST products with provisions different from the information set forth herein shall void any warranty granted by ST for such product.

ST and the ST logo are trademarks of ST. For additional information about ST trademarks, please refer to [www.st.com/trademarks](http://www.st.com/trademarks). All other product or service names are the property of their respective owners.

Information in this document supersedes and replaces information previously supplied in any prior versions of this document.

© 2020 STMicroelectronics – All rights reserved