

MATERIAL NUMBER

OLD PART NUMBER

1300360006

DN4100

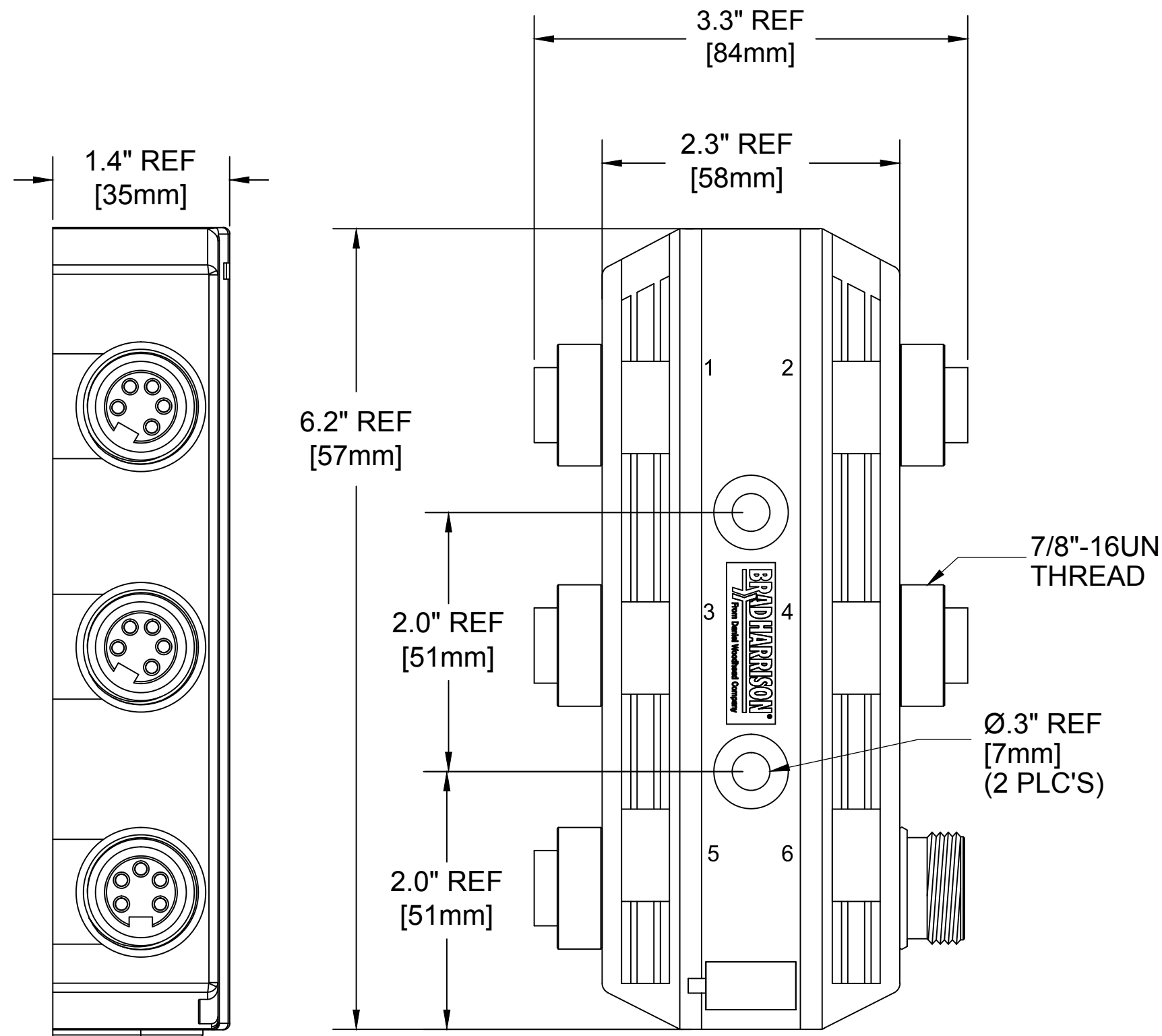

SCHEMATIC

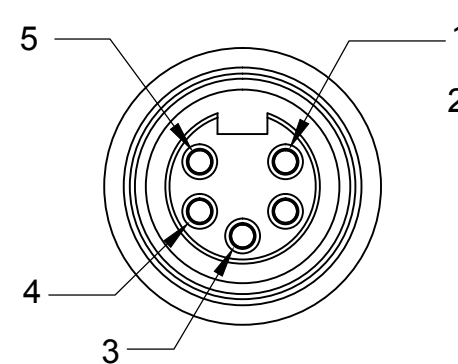
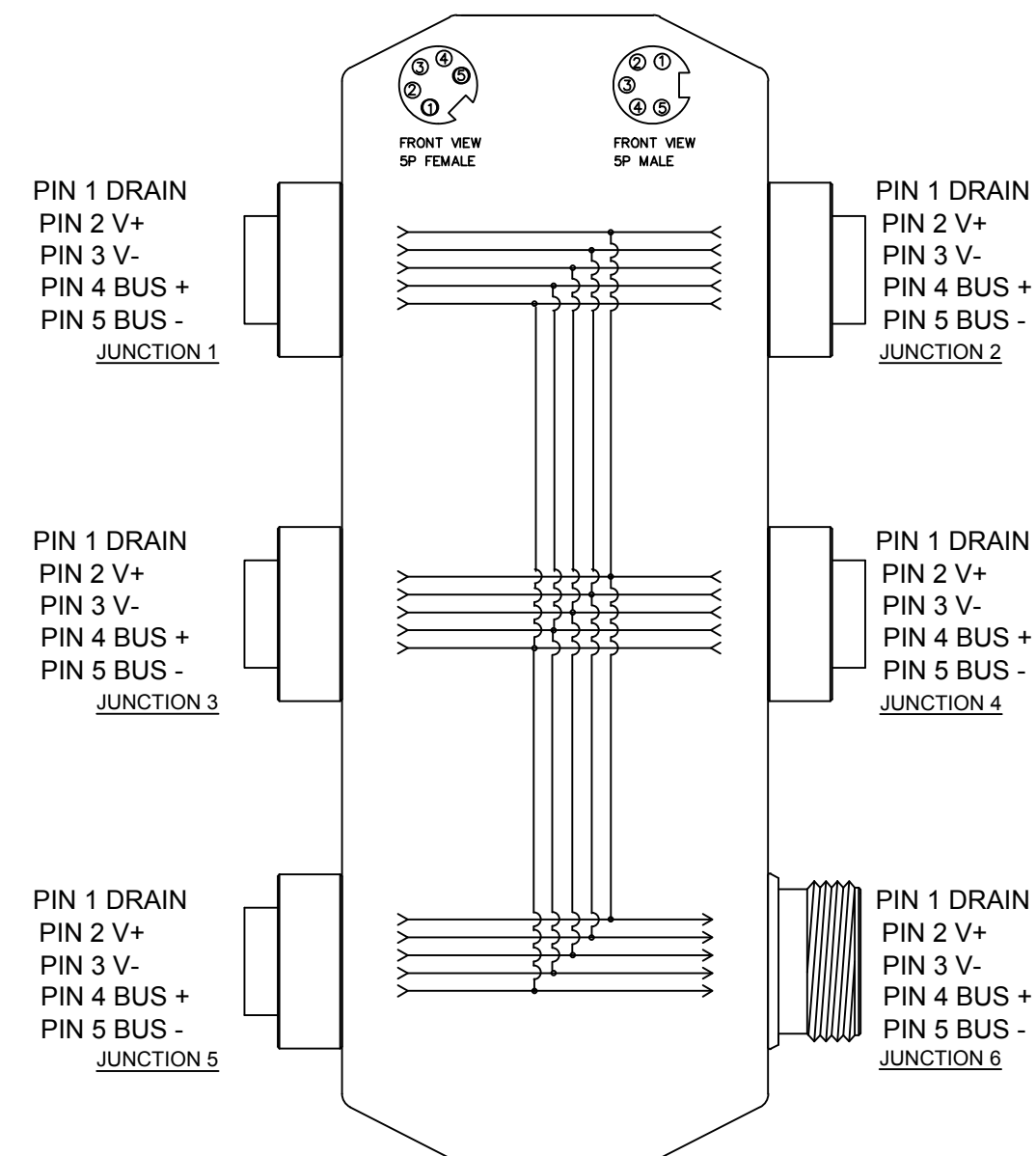

FEMALE FACE VIEW

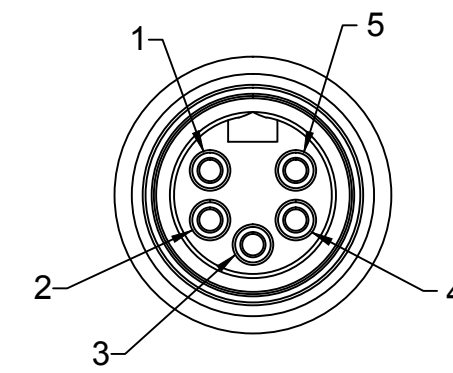

MALE FACE VIEW

SPECIFICATION DATA

COMPONENT	MATERIAL	FINISH
LABEL	ABS	WHITE
HOUSING	PBT	BLACK
CONTACT	COPPER ALLOY	Au OVER Ni
INSERT	PVC	GRAY
POTTING MATERIAL	EPOXY	BLACK
RECEPTACLE SHELL	ZINC DIE CAST	BLACK E-COATED
VOLTAGE RATING:	120 VAC/VDC	
AMPERAGE RATING:	7A	
PROTECTION CLASS:	IP 67	
OPERATING TEMPERATURE:	0°C / 60°C	

UPDATED DRAWING EC NO.: ICG2014-0099 DRWN: GGUSTAFS 2014/01/02 CH'KD: BARDEN APPR: BWOODMAN	QUALITY SYMBOL ▽=0 ▽C=0	GENERAL TOLERANCES (UNLESS SPECIFIED) mm INCH 4 PLACES ±--- ±--- 3 PLACES ±--- ±.005 2 PLACES ±.13 ±.010 1 PLACE ±.25 ±.020	DIMENSION STYLE IN/MM DRAWN BY DATE GGUSTAFS 2014/01/02 CHECKED BY DATE ---- APPROVED BY DATE ----	SCALE NTS DESIGN UNITS INCH THIRD ANGLE PROJECTION	TITLE MC 4 PORT PASS-THRU MPIS DEVICENET
	ANGULAR ±.5° DRAFT WHERE APPLICABLE MUST REMAIN WITHIN DIMENSIONS		MATERIAL NO. SEE CHART	DOCUMENT NO. SD-130036-004	SHEET NO. 1 OF 1
	MOLEX INCORPORATED				
	THIS DRAWING CONTAINS INFORMATION THAT IS PROPRIETARY TO MOLEX INCORPORATED AND SHOULD NOT BE USED WITHOUT WRITTEN PERMISSION				