



NOTE

All numerical values are in metric units [with U.S. customary units in brackets]. Dimensions are in millimeters [and inches]. Unless otherwise specified, dimensions have a tolerance of ± 0.13 [$\pm .005$] and angles have a tolerance of $\pm 2^\circ$. Figures and illustrations are for identification only and are not drawn to scale.

1. INTRODUCTION

This specification covers the requirements for application of ICCON INSERT Pin and Socket Connector System, ICCON BLOCK Pin and Socket Connector System and ICCON SLIM Power Pin and Socket Connector System. These connectors are designed to provide a reliable, high-current power interconnection with quick connect/disconnect function for space-constrained, motherboard-daughterboard, busbar-busbar, and board-busbar power delivery application.

ICCON INSERT Pin and Socket Connector System has surface solder mount socket for PCB, knurl joint socket for bus bar, screw mount pin for PCB and bus bar, and knurl joint pin for bus bar. ICCON INSERT is recommended to use for mezzanine application. ICCON BLOCK Pin and Socket Connectors have precision formed compliant pins that can be used for press-fit application. ICCON SLIM Pin and Socket Connectors have solder type tails that can be used for Pin-In-Paste reflow or wave soldering process. ICCON SLIM is recommended to use for orthogonal application.

When corresponding with TE Connectivity Personnel, use the terminology provided in this specification to facilitate your inquiries for information. Basic terms and features of this product are provided in Figure 1.

ICCON INSERT Pin and Socket

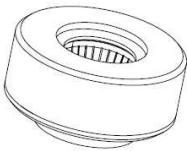

Surface Solder Mount Socket

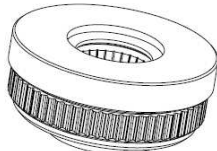

Knurl Joint Socket

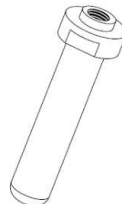

Screw Mount Pin

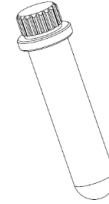

Knurl Joint Pin

ICCON BLOCK Pin and Socket

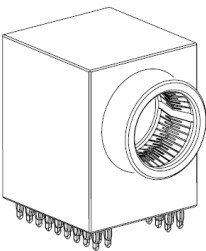

Right Angle Press-fit Socket

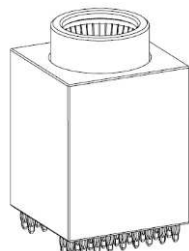

Vertical Press-fit Socket

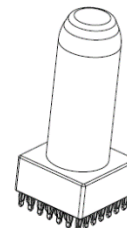

Vertical Press-fit Pin

ICCON SLIM Pin and Socket

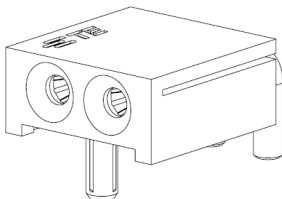

Dual Pole Socket

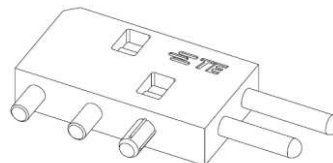

Dual Pole Pin

Figure 1

The ICCON INSERT Pin connectors are available in diameter size 3.6mm, 6.0mm and 8.0mm. The Socket connectors are available in different size for supporting pin diameter 3.6mm, 6.0mm and 8.0mm. The ICCON BLOCK Pin connectors are available in diameter size above 6.0mm. The Socket connectors are available in different size for supporting pin diameter above 6.0mm. The ICCON SLIM Pin connectors are available in diameter size 2.4mm. The Socket connectors are available for supporting pin diameter 2.4mm.

2. REFERENCE MATERIAL

2.1. REVISION SUMMARY

Initial release of application specification

2.2. CUSTOMER ASSISTANCE

Reference Product Base Part Number 2361483 (ICCON INSERT SOCKET), 2361493 (ICCON INSERT PIN), 2358715 (ICCON BLOCK SOCKET), 2358714 (ICCON BLOCK PIN), 2367215 (ICCON SLIM SOCKET) and 2367216 (ICCON SLIM PIN), and Product Code H885 are representative of ICCON Power Pin and Socket Connectors. Use of these numbers will identify the product line and help you to obtain product and tooling information. Such information can be obtained through a local TE Representative, by visiting our website at www.te.com, or by calling PRODUCT INFORMATION or the TOOLING ASSISTANCE CENTER at the numbers at the bottom of page 1.

2.3. DRAWING

Customer Drawings for product part numbers are available from the service network. If there is a conflict between the information contained in the Customer Drawings and this specification or with any other technical documentation supplied, the information contained in the Customer Drawings takes priority.

3. REQUIREMENTS

3.1. Printed Circuit Board – ICCON INSERT

A. Material and Thickness

The pc board material shall be glass epoxy (FR-4 or G-10). The minimum pc board thickness range for solder application is 1.30 mm [.052 in.]. The minimum pc board thickness range for screw mount application is 2.00 mm [.079 in.].

B. Hole Dimensions and Plating

The contact holes must be drilled and plated through to specific dimensions to prevent stubbing during placement of the connector on the pc board and to ensure optimum continuity for circuits. If applicable, holes for the board-locks or mounting hardware may be used with or without plated through holes. The drilled hole size, plating types, plating thickness, and finished hole size must be as stated to provide unrestricted insertion. See Figure 2.

C. Pads

The pc board circuit pads must be solderable in accordance with Test Specification 109-11.

D. Layout

The holes in the pc board must be precisely located to ensure proper placement and optimum performance. The pc board layout must be designed using the dimensions provided on the customer drawing for the specific connector. A sample of the recommended pc board layout is shown in Figure 3.

E. Spacing

Care must be used to avoid interference between adjacent connectors and other components.

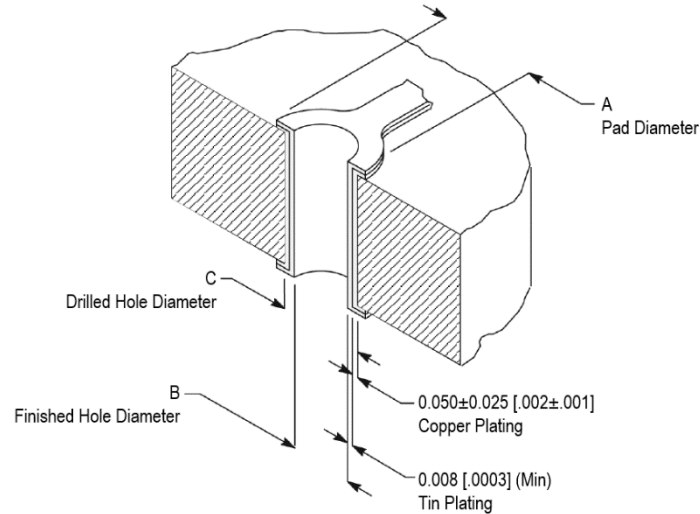

Diameter Dimensions	Socket			Pin		
	ICCON INSERT Socket for 3.6mm Pin	ICCON INSERT Socket for 6.0mm Pin	ICCON INSERT Socket for 8.0mm Pin	ICCON INSERT 3.6mm Pin	ICCON INSERT 6.0mm Pin	ICCON INSERT 8.0mm Pin
A Pad Diameter	14.60±0.20	17.00±0.20	19.00±0.20	8.30±0.20	11.00±0.20	13.00±0.20
B Finished Hole Diameter	9.70+0.10/0	12.10+0.10/0	14.10+0.10/0	5.20±0.05	6.05±0.05	7.20±0.05
C Drilled Hole Diameter	9.85	12.25	14.25	5.30	6.15	7.30

Figure 2

Sample Recommended PC Board Layout As Viewed from Connector Side
(ICCON INSERT Socket for 8.0mm Pin Shown)

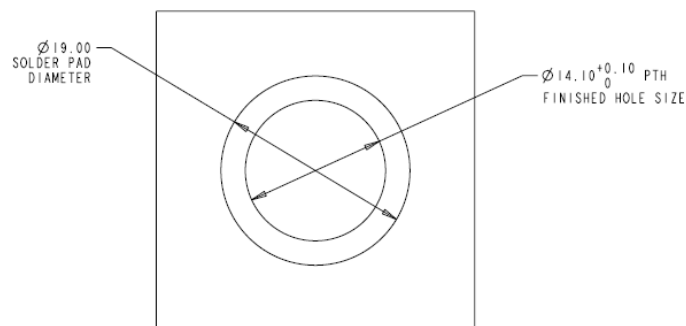

Figure 3

3.2. Printed Circuit Board – ICCON BLOCK

A. Material and Thickness

The pc board material shall be glass epoxy (FR-4 or G-10). The minimum pc board thickness for press-fit application is 2.0 mm [.079 in.]. The minimum pc board thickness range for solder application is 1.30 mm [.052 in.].

B. Hole Dimensions, Plating and Durability

The contact holes must be drilled and plated through to specific dimensions to prevent stubbing during placement of the connector on the pc board and to ensure optimum continuity for circuits. If applicable,

holes for mounting hardware may be used with or without plated through holes. The drilled hole size, plating types, plating thickness, and finished hole size must be as stated to provide unrestricted insertion. See Figure 4.

For connectors with press-fit contacts, the pc board holes cannot withstand connector removal more than three times. The radius of any board hole must not increase more than 0.038 mm [.0015 in.] or decrease less than 0.0508 mm [.002 in.].

C. Pads

The pc board circuit pads must be solderable in accordance with Test Specification 109-11.

D. Layout

The holes in the pc board must be precisely located to ensure proper placement and optimum performance. The pc board layout must be designed using the dimensions provided on the customer drawing for the specific connector. A sample of the recommended pc board layout is shown in Figure 5.

E. Spacing

Care must be used to avoid interference between adjacent connectors and other components.

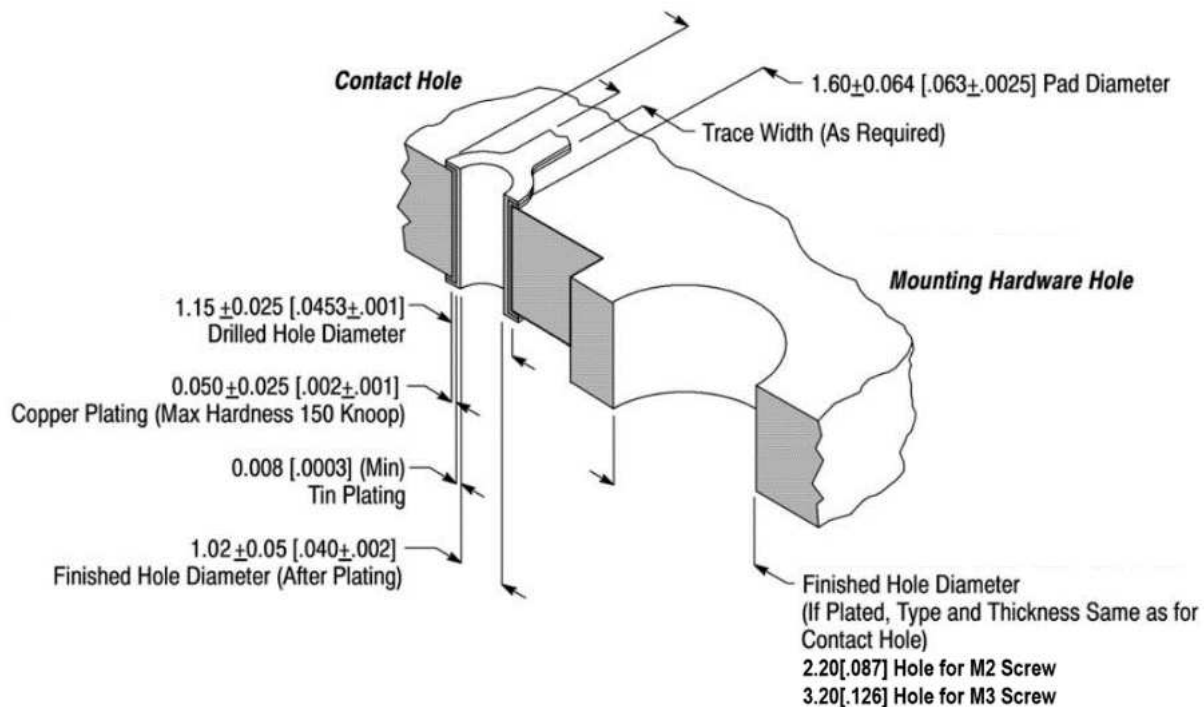

Figure 4

Sample Recommended PC Board Layout As Viewed from Connector Side
(ICCON BLOCK Socket for 10.3mm Pin Shown)

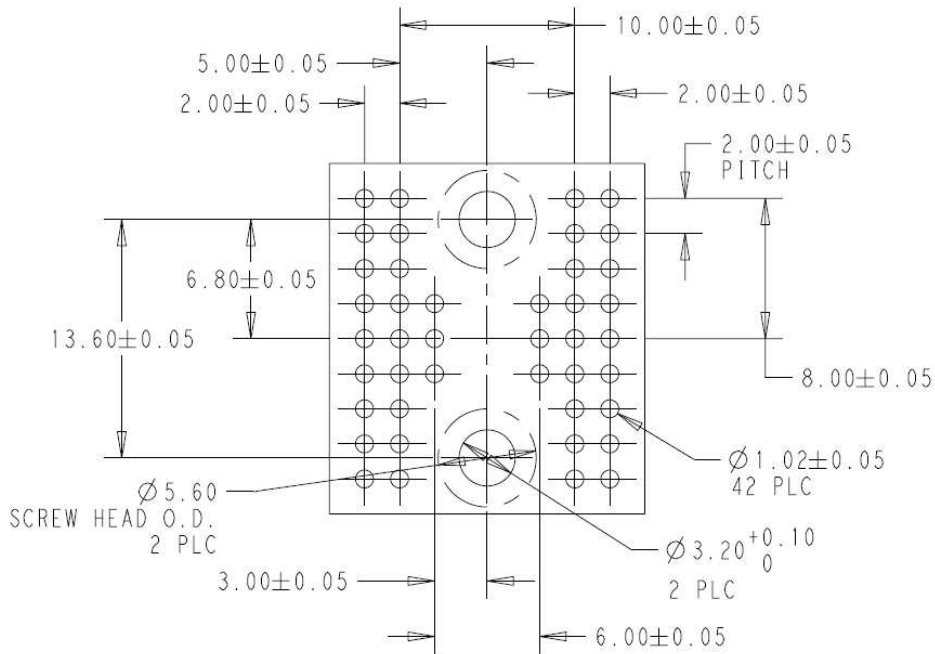

Figure 5

3.3. Printed Circuit Board – ICCON SLIM

A. Material and Thickness

The pc board material shall be glass epoxy (FR-4 or G-10). The minimum pc board thickness range for solder application is 1.30 mm [.052 in.].

B. Hole Dimensions and Plating

The contact holes must be drilled and plated through to specific dimensions to prevent stubbing during placement of the connector on the pc board and to ensure optimum continuity for circuits. If applicable, holes for mounting hardware may be used with or without plated through holes. The drilled hole size, plating types, plating thickness, and finished hole size must be as stated to provide unrestricted insertion. See Figure 6.

C. Pads

The pc board circuit pads must be solderable in accordance with Test Specification 109-11.

D. Layout

The holes in the pc board must be precisely located to ensure proper placement and optimum performance. The pc board layout must be designed using the dimensions provided on the customer drawing for the specific connector. A sample of the recommended pc board layout is shown in Figure 7.

E. Spacing

Care must be used to avoid interference between adjacent connectors and other components.

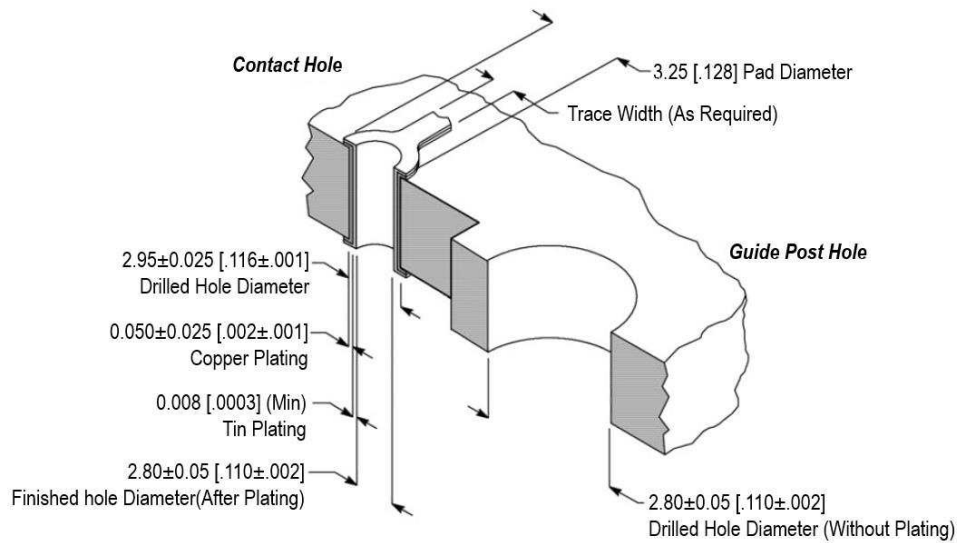

Figure 6

*Sample Recommended PC Board Layout As Viewed from Connector Side
(ICCON SLIM Socket for 2.4mm Pin Shown)*

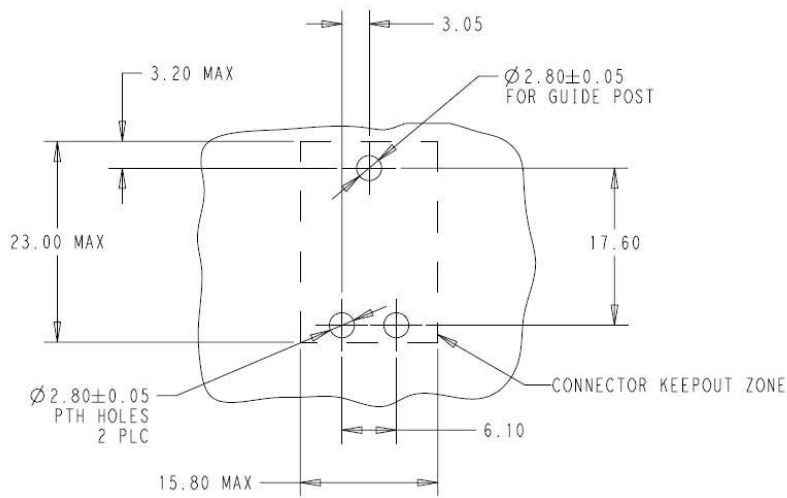

Figure 7

3.4. Bus Bar

A. Material and Thickness

For optimum performance, the bus bar must be made of highly conductive copper (101% @ 20°C [68°F] per International Anneal Copper Standards {IACS}), and tin plated 0.00127 mm [0.00050 in.] minimum over 0.00127 to 0.00254 mm [0.00050 to .00010 in.] nickel plating. The minimum Bus Bar thickness for press-fit application is 2.0 mm [0.079 in].

B. Layout

The holes in the bus bar must be precisely located to ensure proper placement and optimum performance. The bus bar layout must be designed using the dimensions provided on the customer drawing for the specific connector

3.5. Screw Mounting

A. Mounting Hardware

Connectors with mounting holes or threads can be secured to the pc board or bus bar using commercially-available standard screws. The screw size and recommended torque (applied to the mating face of the connector) is provided in Figure 8. The screw sizes are shown in part drawings.

SCREW	RECOMMENDED TORQUE Nm
M2	0.4
M2.5	0.4
M3	0.5
M4	1.2
M5	2.0
M6	2.5

Figure 8

B. Mounting Process

Lay the connector onto pc board or bus bar hole, then screw the stud with washers, including a spring washer or conical washer for fasten. A sample of the pin mounting process is shown in Figure 9.

Sample pin mounting process



Figure 9

3.6. Connector Placement



CAUTION

Connectors should be handled only by the housing to avoid deformation, contamination, or damage to the contacts

A. Registration

When placing connectors on the pc board, contacts and, if applicable, board-locks or mounting screws must be aligned and started into the matching holes before seating the connector onto the pc board.

B. Insertion Force

The force required to seat the connector with press-fit tails onto the pc board can be calculated by:

$$\text{Number of connector press-fit tails} \times \text{maximum insertion force per contact N [lb]} = \text{insertion force N [lb]}$$

The maximum amount of insertion force per tail is 111.2N (25lb).

3.7. Connector Mating

A. Misalignment

For ICCON BLOCK, ICCON INSERT and ICCON SLIM, when mating connectors, side-to-side and up-and-down misalignment is allowed to the dimensions given in Figure 10.



CAUTION:

For ICCON INSERT, the misalignment is 1mm after floating. For 2.4 diameter pin and socket pair, the misalignment is 1mm.

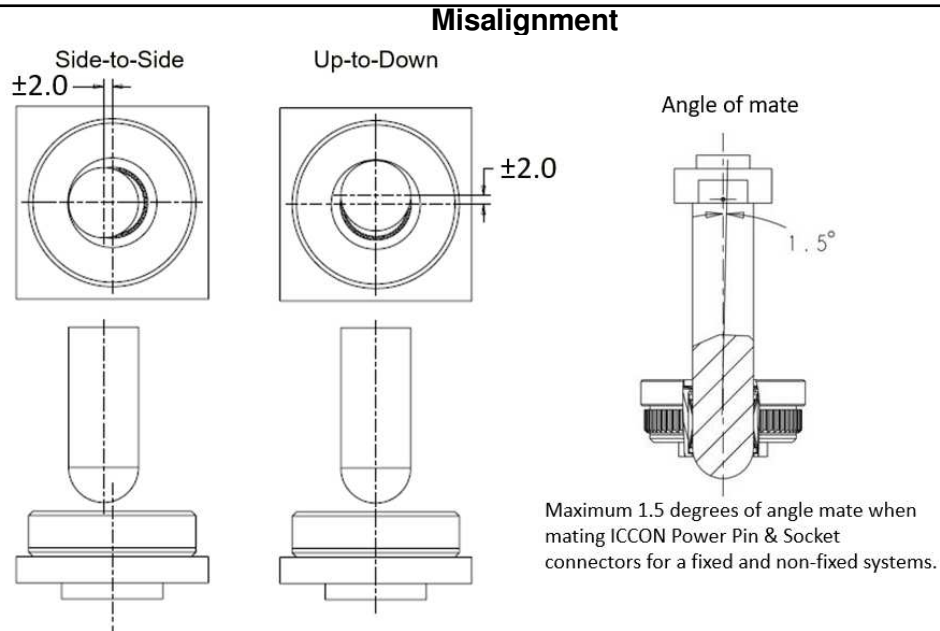

Figure 10

B. Floating

Fit for ICCON INSERT socket only. After mating connectors, ICCON INSERT Power Pin & Socket connectors floating is allowed to the dimensions given in Figure 11.

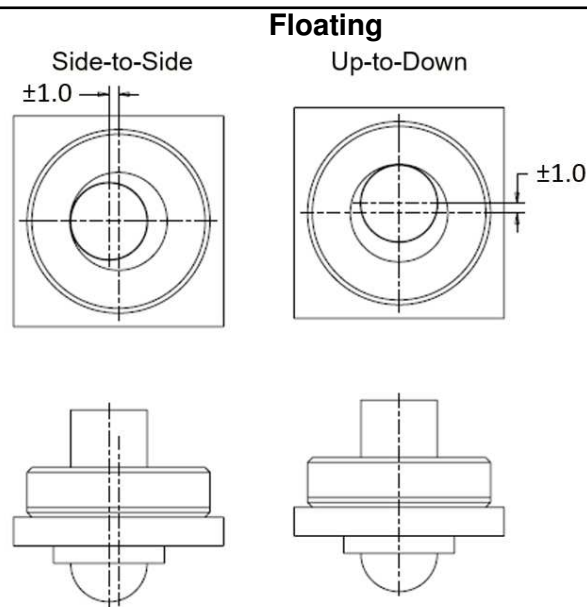

Figure 11

C. Wipe Length

Wipe length for these connectors is defined as that portion (length) of the mating contacts that touches (wipes) from the point of engagement to the point of being fully mated. The wipe length at the level of mating for ICCON BLOCK, ICCON INSERT and ICCON SLIM, is listed in Figure 12.

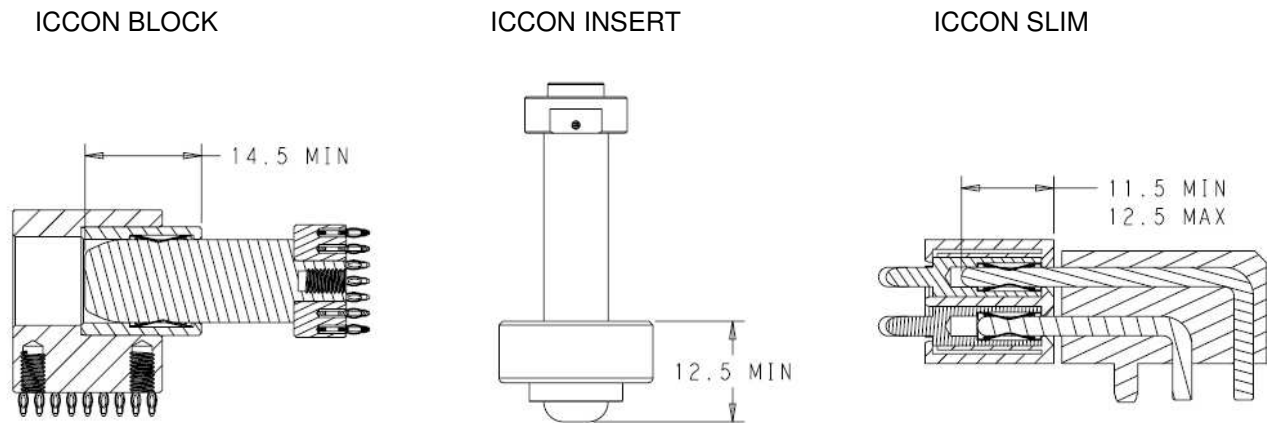

Figure 12

The minimum wipe length of ICCON BLOCK is 14.5mm MIN. The minimum wipe length of ICCON BLOCK is 12.5mm MIN. The wipe length of ICCON slim is 11.5mm to 12.5mm.

D. Pin Length Selection for Mezzanine Application

ICCON Power Pin and Socket can be used in mezzanine application. Pin should be top entry into socket, the pin length should be the distance of PC Board to PC Board plus 0.25mm MIN.

Refer to Figure 13. The pin length dimension shows in pin drawings.

Pin top entry into socket

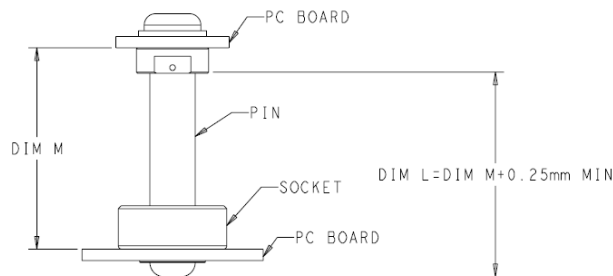

Figure 13

4. QUALIFICATIONS

ICCON SLIM Power Pin & Socket connectors will be component recognized by Underwriters Laboratories Inc.(UL) under file E28475.

5. TOOLING

5.1. Solder type connectors

No tooling is required for placement of the solder type connectors onto the pc board.

5.2. Screw mount type connectors

No tooling is required for placement of the solder type connectors onto the pc board.

5.3. Connector with Press-fit Contacts

A. Application Tooling

The application tooling (such as an arbor press) used to seat these connectors must provide sufficient amount of downward force to insert the contacts into the pc board holes. Refer to Figure 13

B. PC Board Support

A pc board support must be used to prevent bowing of the pc board during the placement of these connectors on the board. The board support must have a flat surface with holes or a channel large enough and deep enough to receive any protruding components. The pc board must be secured to the board support to prevent movement of the board during seating. Refer to Figure 13.

The board support must also be used when removing these connectors from the pc board.

C. Flat Rock Tooling

Commercially available bar stock (flat rock tooling) with a flat surface large enough to cover all contacts must be used with the application tooling to seat these connectors.

For removing these connectors from the pc board, it is suggested that the pc board be supported from the connector side and that the connector be removed using flat rock tooling.

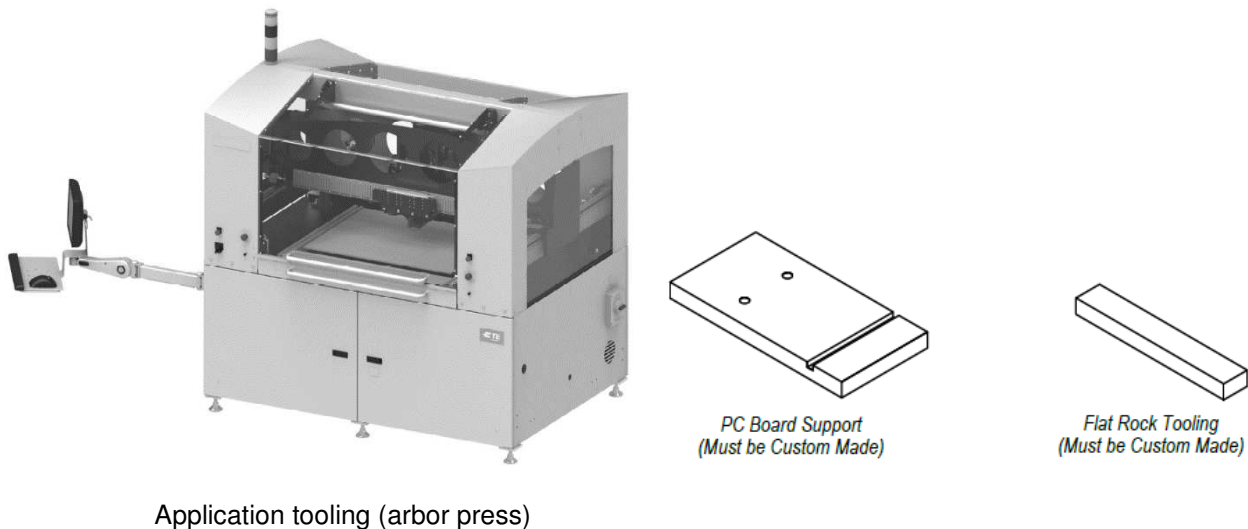
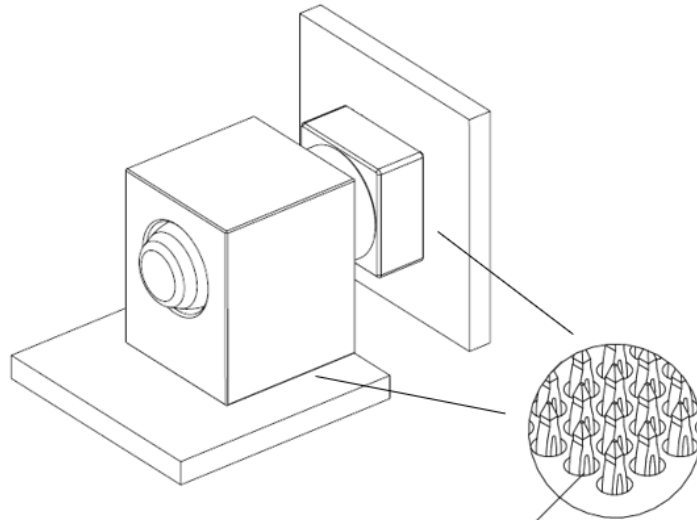

Figure 13

6. VISUAL AID

The illustration below shows a typical application of this product. This illustration should be used by production personnel to ensure a correctly applied product. Applications which DO NOT appear correct should be inspected using the information in the preceding pages of this specification and in the instructional material shipped with the product or tooling.



**CONNECTORS USED FOR
PRESS-FIT APPLICATION**

**ENTIRE "EYE" OF EACH CONTACT
MUST BE WITHIN PC BOARD HOLE**

Figure 15 VISUAL AID