

# AZ DISPLAYS

---

## SPECIFICATIONS FOR LIQUID CRYSTAL DISPLAY

CUSTOMER APPROVAL			
※ PART NO. : <u>ATM1560L1-CT (AZ DISPLAYS) VER1.0</u>			
APPROVAL		COMPANY CHOP	
CUSTOMER COMMENTS			

AZ DISPLAYS ENGINEERING APPROVAL		
DESIGNED BY	CHECKED BY	APPROVED BY

**REVISION RECORD**

REVISION	REVISION DATE	PAGE	CONTENTS
<b>VER1.0</b>	<b>09/30-2020</b>		<b>FIRST ISSUED</b>

※ **CONTENTS**

1. GENERAL SPECIFICATIONS
2. MECHANICAL SPECIFICATION
3. PIN ASSIGNMENT
4. OPERATING SPECIFICATIONS
5. OPTICAL SPECIFICATIONS
6. RELIABILITY TEST
7. MECHANICAL DRAWING
8. PRECAUTION FOR USING LCM
9. INSPECTION SPECIFICATION

## 1. GENERAL SPECIFICATIONS

ATM1560L1-CT is a 15.6" TFT Liquid Crystal Display module with LED backlight unit and a 40-pin LVDS interface. It features a PCAP touch interface that can be connected via USB or I2C bus. The LCD has a 1920 x 1080 FHD resolutions and is based the an IPS technology supporting 16,194,277 colors.

Item	Specification	Remark
1. LCD size	15.6 inch(Diagonal)	
2. Driver element	a-Si TFT active matrix	
3. Resolution	1920 x 1080	
4. Display mode	Normally black	
5. Dot Pitch (W*H)	0.17925 (H) x 0.17925 (V)	
6. Active Area (W*H)	344.16 (H) x 193.59 (V)	
7. Module size (W*H)	387.73mm(W) x 237.09mm(H) x 12.05 mm(D)	Note 1
8. Surface treatment	Glare	
9. Color arrangement	RGB-stripe	
10. Interface LCD	LVDS	
11. Interface touch	USB, I2C	
12. Backlight power consumption	12 W	
13. Panel power consumption	4 W	
14. Weight	1520 g	
15. RoHS	ROHS compliant	

**Note 1:** Please refer to mechanical drawing.

## 2.0 MECHANICAL SPECIFICATION

Item		Min.	Typ.	Max.	Unit
LCD Module Size	Horizontal (H)	363.3	363.8	364.3	mm
	Vertical (V)	215.4	215.9	216.4	mm
Assembly Size	Horizontal (H)	387.43	387.73	388.03	mm
	Vertical (V)	236.79	237.09	237.39	mm
	Thickness (T)	11.1	12.05	13.0	mm

### 3. PIN ASSIGNMENT

#### 3.1 LVDS CONNECTOR

Pin	Name	Description
1	LED_Vcc	+12V Vi power supply
2	LED_Vcc	+12V Vi power supply
3	LED_Vcc	+12V Vi power supply
4	LED_Vcc	+12V Vi power supply
5	GND	Ground
6	GND	Ground
7	GND	Ground
8	GND	Ground
9	LED_EN	Enable pin
10	LED_PWM	Backlight Adjust
11	LCD_VCC	LCD logic and driver power 3.3V
12	LCD_VCC	LCD logic and driver power 3.3V
13	LCD_VCC	LCD logic and driver power 3.3V
14	NC	Not connection, this pin should be open
15	NC	Not connection, this pin should be open
16	NC	Not connection, this pin should be open
17	LCD GND	LCD logic and driver ground
18	RXO0-	Negative LVDS differential data input. Channel O0 (odd)
19	RXO0+	Positive LVDS differential data input. Channel O0 (odd)
20	RXO1-	Negative LVDS differential data input. Channel O1 (odd)
21	RXO1+	Positive LVDS differential data input. Channel O1 (odd)
22	RXO2-	Negative LVDS differential data input. Channel O2 (odd)
23	RXO2+	Positive LVDS differential data input. Channel O2 (odd)
24	LCD GND	LCD logic and driver ground
25	RXOC-	Negative LVDS differential clock input. (odd)
26	RXOC+	Positive LVDS differential clock input. (odd)
27	LCD GND	LCD logic and driver ground
28	RXO3-	Negative LVDS differential data input. Channel O3(odd)
29	RXO3+	Positive LVDS differential data input. Channel O3 (odd)
30	RXE0-	Negative LVDS differential data input. Channel E0 (even)
31	RXE0+	Positive LVDS differential data input. Channel E0 (even)
32	RXE1-	Negative LVDS differential data input. Channel E1 (even)
33	RXE1+	Positive LVDS differential data input. Channel E1 (even)
34	LCD GND	LCD logic and driver ground
35	RXE2-	Negative LVDS differential data input. Channel E2 (even)
36	RXE2+	Positive LVDS differential data input. Channel E2 (even)
37	RXEC-	Negative LVDS differential clock input. (even)
38	RXEC+	Positive LVDS differential clock input. (even)
39	RXE3-	Negative LVDS differential data input. Channel E3 (even)
40	RXE3+	Positive LVDS differential data input. Channel E3 (even)

Note (1) Connector Part No.: I-PEX 20455-040E-76 or equivalent.

Note (2) User's connector Part No.: I-PEX 20453-040T-03 or equivalent.

### 3.2 TOUCH PANEL

Pin No.	Symbol	Function
1	GND	Ground
2	I <sup>2</sup> C-SDA	SDA
3	I <sup>2</sup> C-SCL	SCL
4	VDD	5V
5	I <sup>2</sup> C-INT	INT
6	/RST	RESET

Connector: E&T (3802K-E06N-01X)

Pin No.	Symbol	Function
1	GND-EARTH	GROUND EARTH
2	VDD	5V
3	GND	Ground
4	D+	USB signal +
5	D-	USB signal -

Connector: E&T (3802K-E05N-01X)

## 4. OPERATING SPECIFICATIONS

### 4.1 ABSOLUTE MAXIMUM RATINGS

Item	Symbol	Values		Unit	Remark
		Min.	Max.		
Power Voltage	$V_{CC}$	-0.3	3.6	V	Note 1
Logic Input Voltage	$V_{IN}$	-0.3	4.0	V	Note 1
Operation Temperature	$T_{OP}$	-20	70	°C	
Storage Temperature	$T_{ST}$	-40	80	°C	Note 1, 2
LED Voltage	LED $V_{IN}$	0	18	V	Note 1
LED Forward Current	$I_{LED}$	0.8	1.2	A	$V_{in} = 12V$ 100% duty

**Note 1:** The absolute maximum rating values of this product are not allowed to be exceeded at any times. Should a module be used with any of the absolute maximum ratings exceeded, the characteristics of the module may not be recovered, or in an extreme case, the module may be permanently destroyed.

**Note 2:** Temperature and relative humidity range is shown in the figure below.

- (a) 90 %RH Max. ( $T_a \leq 40$  °C).
- (b) Wet-bulb temperature should be 39 °C Max. ( $T_a > 40$  °C).
- (c) No condensation.

#### 4.1.1 Typical Operation Conditions

Item	Symbol	Values			Unit	Remark
		Min.	Typ.	Max.		
Power Voltage	$DV_{DD}$	3.15	3.3	3.6	V	
	$V_{RP}$	-	-	150	V	
	$I_{RP}$	-	-	3	A	
POWER CONSUMPTION	PLCD	-	4	5	Watt	
LVDS differential input voltage	$V_{id}$	200		600	mV	
LVDS common input voltage	$V_{ic}$	1.0	1.2	1.4	V	
LVDS terminating resistor	$R_t$		100		Ohm	

### 4.1.2 Backlight driving conditions

Parameter	Symbol	Value			Unit	Note	
		Min.	Typ.	Max.			
Converter Power Supply Voltage	LED_Vin	10.8	12.0	13.2	V		
Converter Power Supply Current	li	0.8	1.0	1.2	A	@LED_Vin= 12V Duty=100%	
Converter Input Rush Current	lirsh			3	A	@LED_Vin rising = 1mS	
Power Consumption	P <sub>LED</sub>		12		W	@ LED_Vin = 12V Duty=100%	
EN Control Level	Backlight on	LED_EN	2.0	5	5.5	V	
	Backlight off		0	0	0.8		
PWM Control Level	PWM High Level	LED_PWM	2.0	3.3	5.0	V	
	PWM Low Level		0	0	0.15		
PWM Control Duty Ratio			10	--	100	%	
PWM Control Frequency		f <sub>PWM</sub>	190	200	20k	Hz	
LED Life Time		L <sub>L</sub>	50,000			Hrs	(2)

Note (1) LED light bar input voltage and current are measured by utilizing a true RMS multimeter as shown below:

Note (2) The lifetime of LED is estimated data and defined as the time when it continues to operate under the conditions at Ta = 25±2°C and Duty 100% until the brightness becomes ≤ 50% of its original value. Operating LED under high temperature environment will reduce life time and lead to color shift.

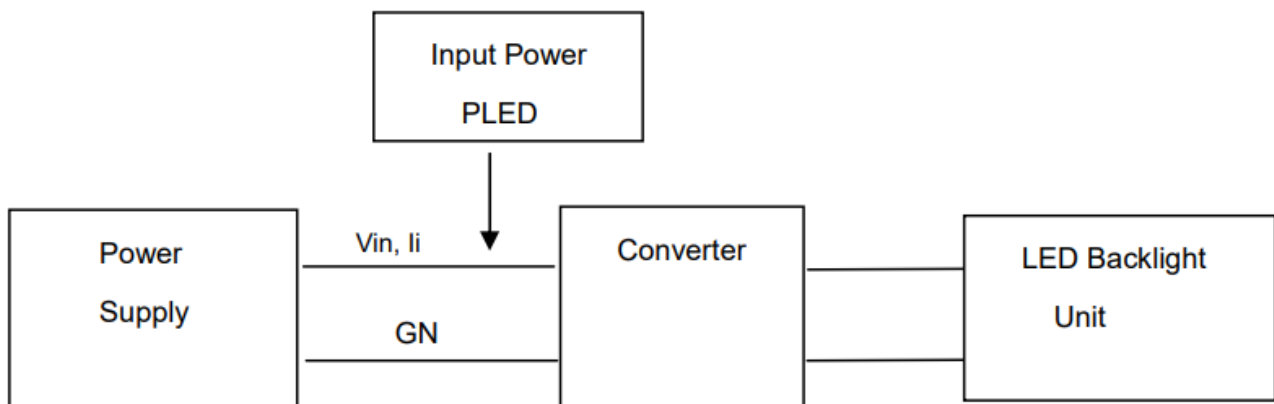



#### 4.2 LVDS INPUT SIGNAL SPECIFICATIONS

LVDS Channel O0	LVDS output	D7	D6	D4	D3	D2	D1	D0
	Data order	OG0	OR5	OR4	OR3	OR2	OR1	OR0
LVDS Channel O1	LVDS output	D18	D15	D14	D13	D12	D9	D8
	Data order	OB1	OB0	OG5	OG4	OG3	OG2	OG1
LVDS Channel O2	LVDS output	D26	D25	D24	D22	D21	D20	D19
	Data order	DE	NA	NA	OB5	OB4	OB3	OB2
LVDS Channel O3	LVDS output	D23	D17	D16	D11	D10	D5	D27
	Data order	NA	OB7	OB6	OG7	OG6	OR7	OR6
LVDS Channel E0	LVDS output	D7	D6	D4	D3	D2	D1	D0
	Data order	EG0	ER5	ER4	ER3	ER2	ER1	ER0
LVDS Channel E1	LVDS output	D18	D15	D14	D13	D12	D9	D8
	Data order	EB1	EB0	EG5	EG4	EG3	EG2	EG1
LVDS Channel E2	LVDS output	D26	D25	D24	D22	D21	D20	D19
	Data order	DE	NA	NA	EB5	EB4	EB3	EB2
LVDS Channel E3	LVDS output	D23	D17	D16	D11	D10	D5	D27
	Data order	NA	EB7	EB6	EG7	EG6	ER7	ER6

### 4.3 COLOR DATA INPUT ASSIGNMENT

The brightness of each primary color (red, green and blue) is based on the 8-bit gray scale data input for the color. The higher the binary input, the brighter the color. The table below provides the assignment of color versus data input.

Color		Data Signal																							
		Red								Green								Blue							
		R7	R6	R5	R4	R3	R2	R1	R0	G7	G6	G5	G4	G3	G2	G1	G0	B7	B6	B5	B4	B3	B2	B1	B0
Basic Colors	Black	0	0	0	0	0	0	0	0	0	0	0	0	0	0	0	0	0	0	0	0	0	0	0	
	Red	1	1	1	1	1	1	1	1	0	0	0	0	0	0	0	0	0	0	0	0	0	0	0	
	Green	0	0	0	0	0	0	0	0	1	1	1	1	1	1	1	0	0	0	0	0	0	0	0	
	Blue	0	0	0	0	0	0	0	0	0	0	0	0	0	0	0	1	1	1	1	1	1	1	1	
	Cyan	0	0	0	0	0	0	0	0	1	1	1	1	1	1	1	1	1	1	1	1	1	1	1	
	Magenta	1	1	1	1	1	1	1	1	0	0	0	0	0	0	0	1	1	1	1	1	1	1	1	
	Yellow	1	1	1	1	1	1	1	1	1	1	1	1	1	1	1	0	0	0	0	0	0	0	0	
	White	1	1	1	1	1	1	1	1	1	1	1	1	1	1	1	1	1	1	1	1	1	1	1	
Gray Scale Of Red	Red(0) / Dark	0	0	0	0	0	0	0	0	0	0	0	0	0	0	0	0	0	0	0	0	0	0		
	Red(1)	0	0	0	0	0	0	0	1	0	0	0	0	0	0	0	0	0	0	0	0	0	0		
	Red(2)	0	0	0	0	0	0	1	0	0	0	0	0	0	0	0	0	0	0	0	0	0	0		
	⋮	⋮	⋮	⋮	⋮	⋮	⋮	⋮	⋮	⋮	⋮	⋮	⋮	⋮	⋮	⋮	⋮	⋮	⋮	⋮	⋮	⋮			
	⋮	⋮	⋮	⋮	⋮	⋮	⋮	⋮	⋮	⋮	⋮	⋮	⋮	⋮	⋮	⋮	⋮	⋮	⋮	⋮	⋮	⋮			
	Red(253)	1	1	1	1	1	1	0	1	0	0	0	0	0	0	0	0	0	0	0	0	0	0		
	Red(254)	1	1	1	1	1	1	1	0	0	0	0	0	0	0	0	0	0	0	0	0	0	0		
	Red(255)	1	1	1	1	1	1	1	1	0	0	0	0	0	0	0	0	0	0	0	0	0	0		
Gray Scale Of Green	Green(0)/Dark	0	0	0	0	0	0	0	0	0	0	0	0	0	0	0	0	0	0	0	0	0	0		
	Green(1)	0	0	0	0	0	0	0	0	0	0	0	0	0	0	1	0	0	0	0	0	0	0		
	Green(2)	0	0	0	0	0	0	0	0	0	0	0	0	0	0	1	0	0	0	0	0	0	0		
	⋮	⋮	⋮	⋮	⋮	⋮	⋮	⋮	⋮	⋮	⋮	⋮	⋮	⋮	⋮	⋮	⋮	⋮	⋮	⋮	⋮	⋮			
	⋮	⋮	⋮	⋮	⋮	⋮	⋮	⋮	⋮	⋮	⋮	⋮	⋮	⋮	⋮	⋮	⋮	⋮	⋮	⋮	⋮	⋮			
	Green(253)	0	0	0	0	0	0	0	0	1	1	1	1	1	1	0	1	0	0	0	0	0	0		
	Green(254)	0	0	0	0	0	0	0	0	1	1	1	1	1	1	1	0	0	0	0	0	0	0		
	Green(255)	0	0	0	0	0	0	0	0	1	1	1	1	1	1	1	1	0	0	0	0	0	0		
Gray Scale Of Blue	Blue(0) / Dark	0	0	0	0	0	0	0	0	0	0	0	0	0	0	0	0	0	0	0	0	0	0		
	Blue(1)	0	0	0	0	0	0	0	0	0	0	0	0	0	0	0	0	0	0	0	0	0	1		
	Blue(2)	0	0	0	0	0	0	0	0	0	0	0	0	0	0	0	0	0	0	0	0	0	1		
	⋮	⋮	⋮	⋮	⋮	⋮	⋮	⋮	⋮	⋮	⋮	⋮	⋮	⋮	⋮	⋮	⋮	⋮	⋮	⋮	⋮	⋮			
	⋮	⋮	⋮	⋮	⋮	⋮	⋮	⋮	⋮	⋮	⋮	⋮	⋮	⋮	⋮	⋮	⋮	⋮	⋮	⋮	⋮	⋮			
	Blue(253)	0	0	0	0	0	0	0	0	0	0	0	0	0	0	0	1	1	1	1	1	1	0		
	Blue(254)	0	0	0	0	0	0	0	0	0	0	0	0	0	0	0	1	1	1	1	1	1	1		
	Blue(255)	0	0	0	0	0	0	0	0	0	0	0	0	0	0	0	1	1	1	1	1	1	1		

Note (1) 0: Low Level Voltage, 1: High Level Voltage

### 4.4 DISPLAY TIMING SPECIFICATIONS

The input signal timing specifications are shown as the following table and timing diagram.

Signal	Item	Symbol	Min.	Typ.	Max.	Unit	Note
LVDS Clock	Frequency	$F_c$	(60)	70.93	(75)	MHz	-
	Period	$T_c$		14.1		ns	
	Input cycle to cycle jitter	$T_{rc1}$	$-0.02 \cdot T_c$		$0.02 \cdot T_c$	ns	(3)
	Input clock to data skew	TLVCCS	$-0.02 \cdot T_c$		$0.02 \cdot T_c$	ns	(4)
	Spread spectrum modulation range	$F_{ckin\_mod}$	$FC \cdot 98\%$		$FC \cdot 102\%$	MHz	(5)
	Spread spectrum modulation frequency	$F_{SSM}$			200	KHz	
Vertical Display Term	Frame Rate	$F_r$	(50)	60	60	Hz	$T_v = T_{vd} + T_{vb}$
	Total	$T_v$	(1090)	1110	(1130)	$T_h$	-
	Active Display	$T_{vd}$	1080	1080	1080	$T_h$	-
	Blank	$T_{vb}$	$T_v - T_{vd}$	30	$T_v - T_{vd}$	$T_h$	-
Horizontal Display Term	Total	$T_h$	(1050)	1065	(1075)	$T_c$	$T_h = T_{hd} + T_{hb}$
	Active Display	$T_{hd}$	960	960	960	$T_c$	-
	Blank	$T_{hb}$	$T_h - T_{hd}$	105	$T_h - T_{hd}$	$T_c$	-

Note (1) Because this module is operated by DE only mode, Hsync and Vsync input signals are ignored.

Note (2) The  $T_v(T_{vd} + T_{vb})$  must be integer, otherwise, this module would operate abnormally.

INPUT SIGNAL TIMING DIAGRAM

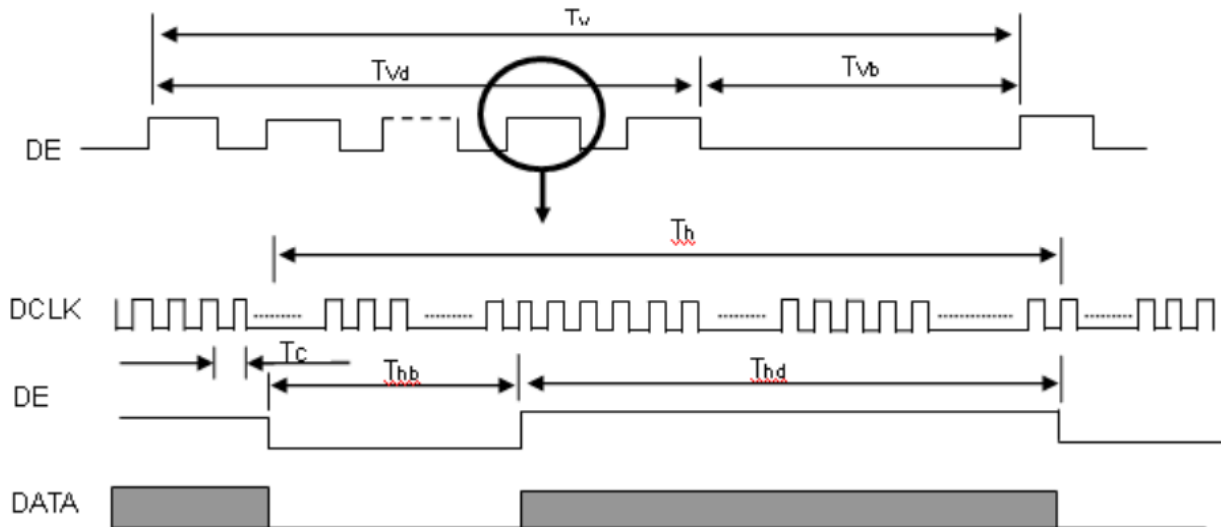

Note (3) The input clock cycle-to-cycle jitter is defined as below figures.  $Trcl = |T_1 - T_1'|$

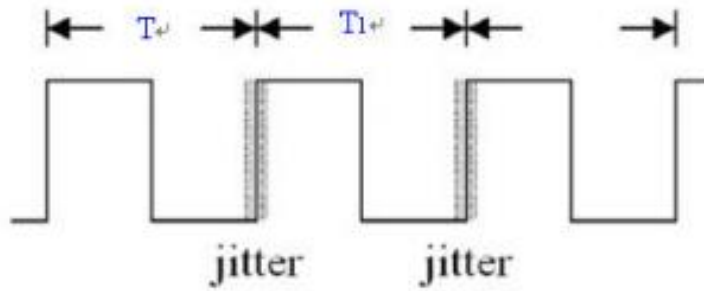

Note (4) Input Clock to data skew is defined as below figures.

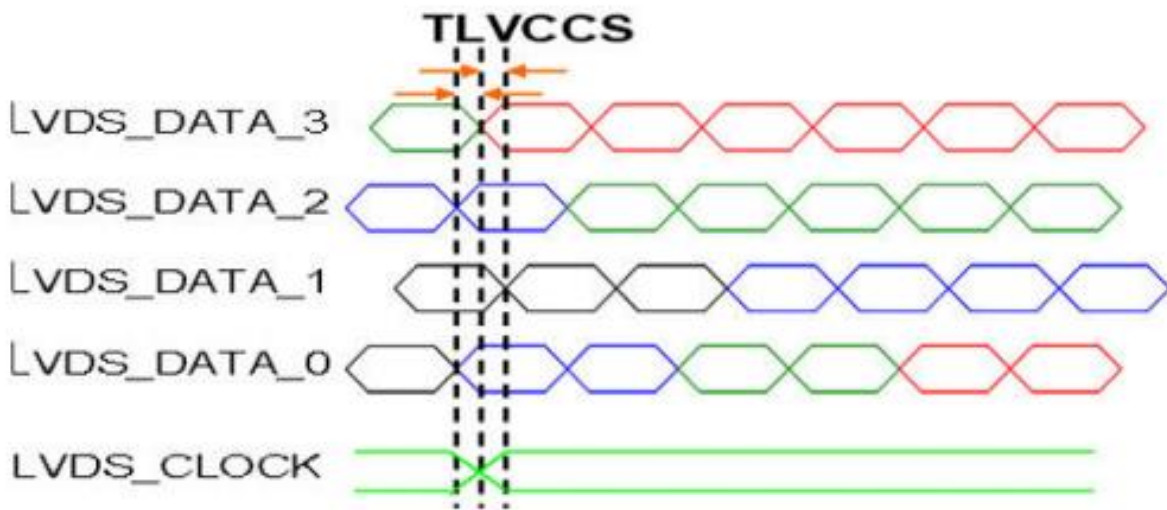

Note (5) The SSCG (Spread spectrum clock generator) is defined as below figures.

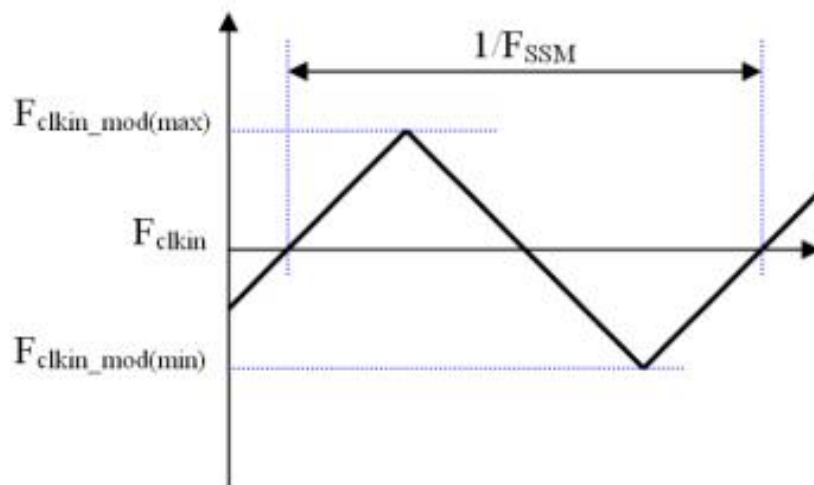

### 4.5 POWER ON/OFF SEQUENCE

The power sequence specifications are shown as the following table and diagram.

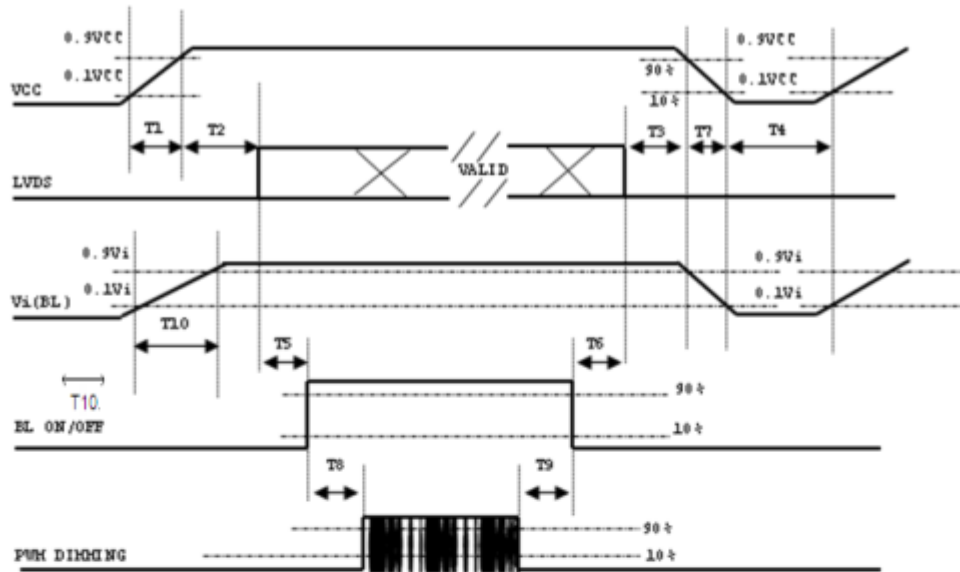

Timing Specifications:

Parameter	Value			Units
	Min	Typ	Max	
T1	0.5	-	10	ms
T2	0	-	50	ms
T3	0	-	50	ms
T4	500	-	-	ms
T5	450	-	-	ms
T6	200	-	-	ms
T7	10	-	100	ms
T8	10	-	-	ms
T9	10	-	-	ms
T10	20	-	50	ms

Note:

- (1) The supply voltage of the external system for the module input should be the same as the definition of Vcc.
- (2) When the backlight turns on before the LCD operation of the LCD turns off, the display may momentarily become abnormal screen.

- (3) In case of VCC = off level, please keep the level of input signals on the low or keep a high impedance.
- (4) T4 should be measured after the module has been fully discharged between power off and on period.
- (5) Interface signal shall not be kept at high impedance when the power is on.
- (6) INX won't take any responsibility for the products which are damaged by the customers not following the Power Sequence.
- (7) There might be slight electronic noise when LCD is turned off (even backlight unit is also off). To avoid this symptom, we suggest "Vcc falling timing" to follow "T7 spec".

**Note:** Data include R0~R7, B0~B7, GO~G7, U/D, L/R, DCLK, HS,VS,DE.

## 5.0 OPTICAL SPECIFICATIONS

### 5.1 TEST CONDITIONS

Item	Symbol	Value	Unit
Ambient Temperature	Ta	25±2	°C
Ambient Humidity	Ha	50±10	%RH
Supply Voltage	According to typical value in "ELECTRICAL CHARACTERISTICS"		
Input Signal			
LED Light Bar Input Current Per Input Pin			

### 5.2 OPTICAL SPECIFICATIONS

The relative measurement methods of optical characteristics are shown in 5.2 and all items are measured at the center point of screen except white variation. The following items should be measured under the test conditions described in 5.1 and stable environment shown in Note (5).

Item	Symbol	Condition	Min.	Typ.	Max.	Unit	Note	
Color Chromaticity (CIE 1931)	Red	Rx	$\theta_x=0^\circ, \theta_y=0^\circ$ CS-2000 R=G=B=255 Gray scale	Typ - 0.05	0.652	Typ + 0.05	-	(1), (5)
		Ry			0.338			
	Green	Gx			0.333			
		Gy			0.613			
	Blue	Bx			0.150			
		By			0.050			
	White	Wx			0.313			
		Wy			0.329			
Center Luminance of White	L <sub>C</sub>		360	450	-	cd/m <sup>2</sup>	(4), (5)	
Contrast Ratio	CR		600	800	-	-	(2), (5)	
Response Time	T <sub>R</sub>	$\theta_x=0^\circ, \theta_y=0^\circ$	-	13	18	ms	(3)	
	T <sub>F</sub>		-	12	17			
White Variation	W	$\theta_x=0^\circ, \theta_y=0^\circ$	70	-	-	%	(5), (6)	
Viewing Angle	Horizontal	$\theta_{x+}$	CR ≥ 10	80	85	Deg.	(1), (5)	
		$\theta_{x-}$		80	85			
	Vertical	$\theta_{y+}$		80	85			
		$\theta_{y-}$		80	85			

Note (1) Definition of Viewing Angle ( $\theta_x, \theta_y$ ):

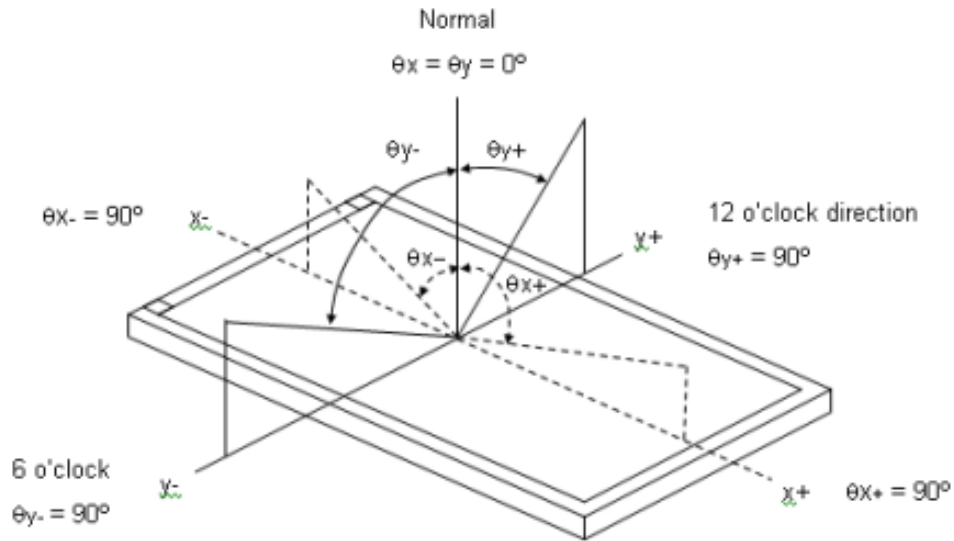

Note (2) Definition of Contrast Ratio (CR):

The contrast ratio can be calculated by the following expression.

$$\text{Contrast Ratio (CR)} = L_{255} / L_0$$

L255: Luminance of gray level 255

L 0: Luminance of gray level 0

$$\text{CR} = \text{CR} (5)$$

CR (X) is corresponding to the Contrast Ratio of the point X at Figure in Note (6).

Note (3) Definition of Response Time ( $T_R, T_F$ ):

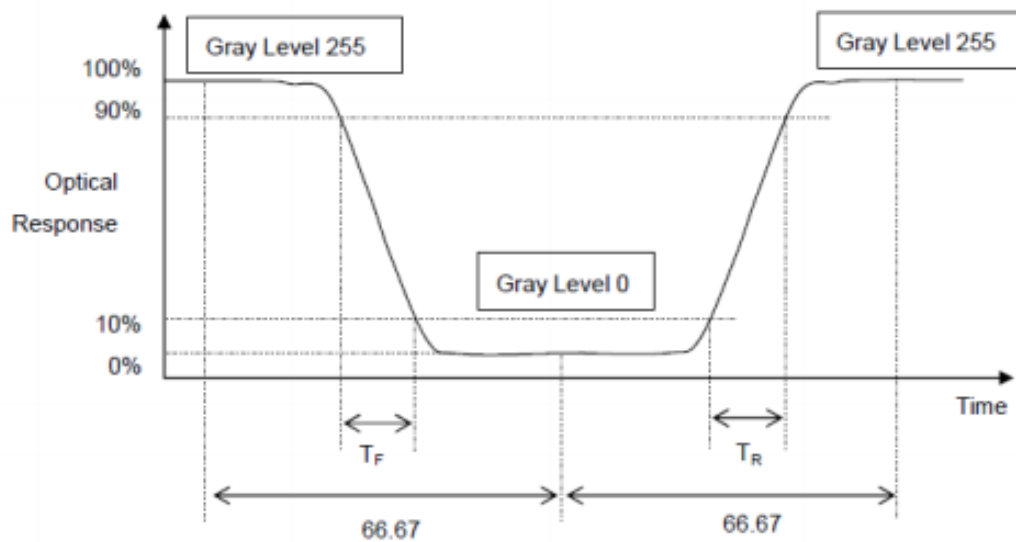



Note (4) Definition of Luminance of White ( $L_C$ ):

Measure the luminance of gray level 255 at center point

$$L_C = L(5)$$

$L(x)$  is corresponding to the luminance of the point X at Figure in Note (6).

Note (5) Measurement Setup:

The LCD module should be stabilized at given temperature for 30 minutes to avoid abrupt temperature change during measuring. In order to stabilize the luminance, the measurement should be executed after lighting Backlight for 30 minutes in a windless room.

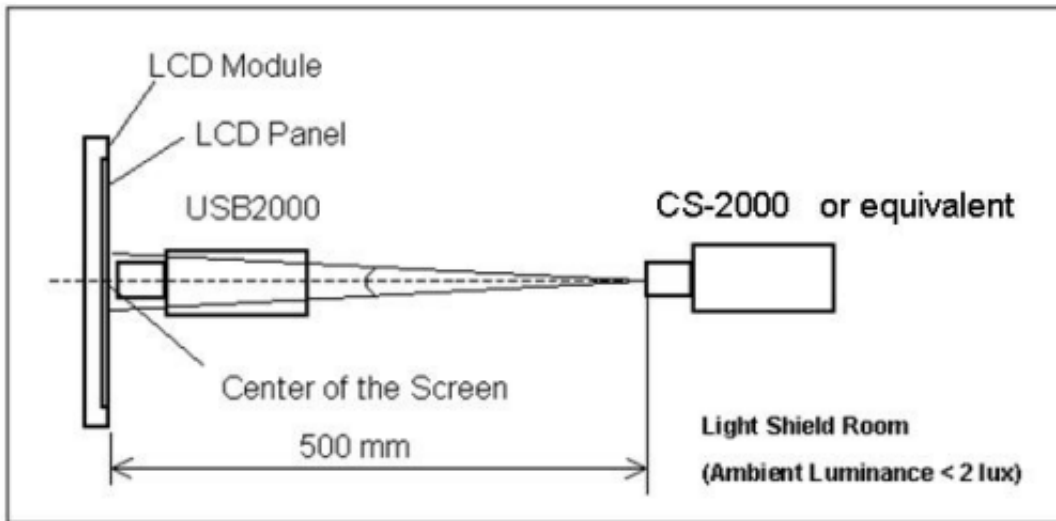

Note (6) Definition of White Variation ( $\delta W$ ):

Measure the luminance of gray level 255 at 9 points

$$\delta W = ( \text{Minimum} [L(1) \sim L(9)] / \text{Maximum} [L(1) \sim L(9)] ) * 100\%$$

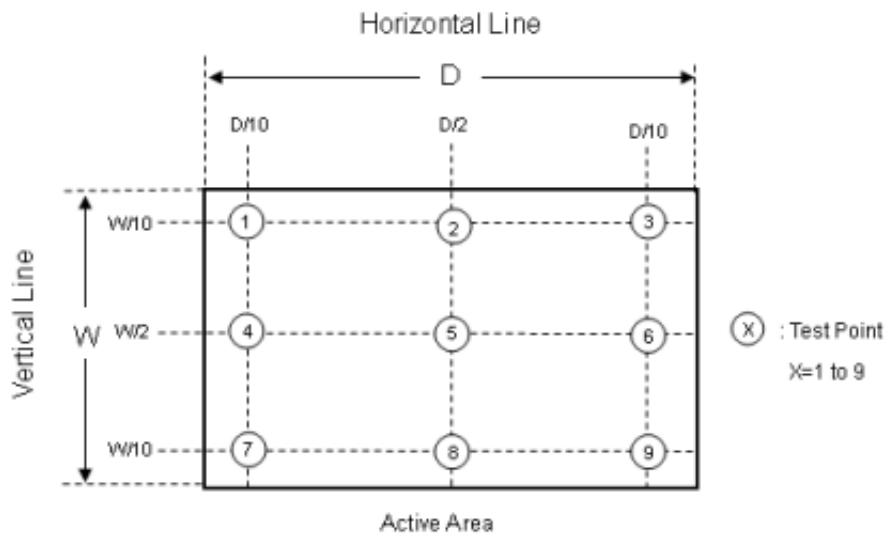

## 6. RELIABILITY TEST

### 6.1 LCD TEST

Test Item	Test Condition	Note
High Temperature Storage Test	85°C, 240 hours	(1)(2) (4)(5)
Low Temperature Storage Test	-30°C, 240 hours	
Thermal Shock Storage Test	-30°C, 0.5hour $\longleftrightarrow$ 85°C, 0.5hour; 1hour/cycle, 100cycles	
High Temperature Operation Test	85°C, 240 hours	
Low Temperature Operation Test	-30°C, 240 hours	
High Temperature & High Humidity Operation Test	60°C, 90%RH, 240hours	(1)(2) (4)(6)
Shock (Non-Operating)	50G, 11ms, half sine wave, 1 time for $\pm X, \pm Y, \pm Z$ .	(2)(3)
Vibration (Non-Operating)	1.5G, 10 ~ 300 Hz, 10min/cycle, 3 cycles each X, Y, Z	(2)(3)

Note (1) There should be no condensation on the surface of panel during test.

Note (2) Temperature of panel display surface area should be 90 °C Max.

Note (3) At testing Vibration and Shock, the fixture in holding the module has to be hard and rigid enough so that the module would not be twisted or bent by the fixture.

Note (4) In the standard conditions, there is no function failure issue occurred. All the cosmetic specification is judged before reliability test.

Note (5) Before cosmetic and function test, the product must have enough recovery time, at least 2 hours at room temperature.

Note (6) Before cosmetic and function test, the product must have enough recovery time, at least 24 hours at room temperature.

6.2 TOUCH TEST

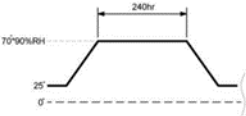
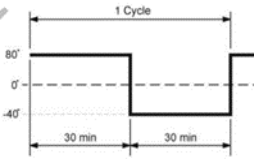
	Item	Condition	Specification
(1)	Constant Temperature / Humidity	70°C X 90%RH, 240 hrs and normalized for 4 hrs 	Satisfy 1.Electrical Characteristics.
(2)	High Temperature storage	80°C /240 hrs and normalized for 4 hrs	
(3)	Low Temperature storage	-40°C /240 hrs and normalized for 4 hrs	
(4)	Thermal Cycle	-40°C ~80°C [60 min./cycle] *50 cycles and normalized for 4 hrs 	

7. MECHANICAL DRAWINGS

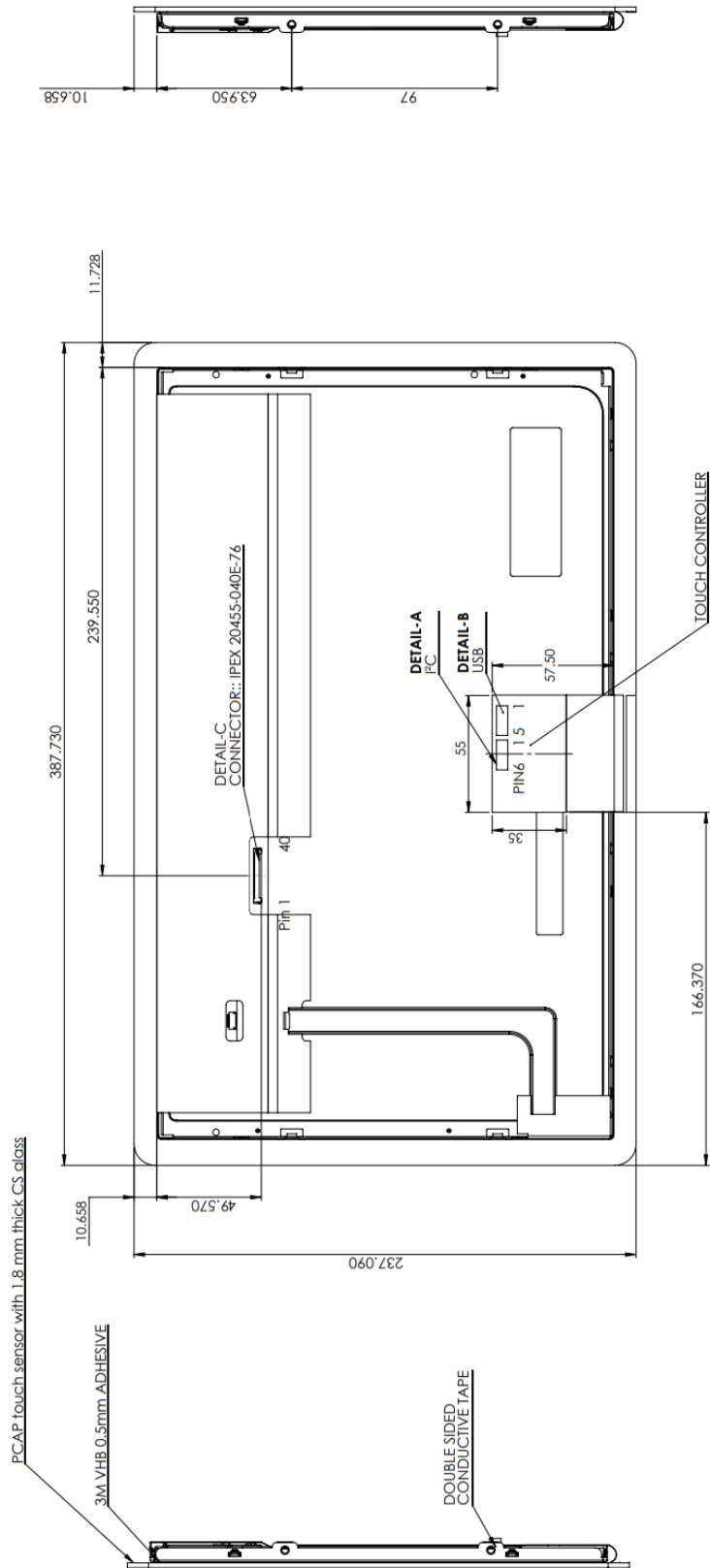

## 8. PRECAUTIONS

### 9.1 ASSEMBLY AND HANDLING PRECAUTIONS

- (1) Do not apply rough force such as bending or twisting to the module during assembly.
- (2) To assemble or install module into user's system can be only in clean working areas. The dust and oil may cause electrical short or worsen the polarizer.
- (3) It's not permitted to have pressure or impulse on the module because the LCD panel and Backlight will be damaged.
- (4) Always follow the correct power sequence when LCD module is connecting and operating. This can prevent damage to the CMOS LSI chips during latch-up.
- (5) Do not pull the I/F connector in or out while the module is operating.
- (6) Do not disassemble the module.
- (7) Use a soft dry cloth without chemicals for cleaning, because the surface of polarizer is very soft and easily scratched.
- (8) It is dangerous that moisture come into or contacted the LCD module, because moisture may damage LCD module when it is operating.
- (9) High temperature or humidity may reduce the performance of module. Please store LCD module within the specified storage conditions.
- (10) When ambient temperature is lower than 10°C may reduce the display quality. For example, the response time will become slowly.

### 9.2 STORAGE PRECAUTIONS

- (1) Do not leave the module in high temperature, and high humidity for a long time. It is highly recommended to store the module with temperature from 0°C to 35°C and relative humidity of less than 70%
- (2) Do not store the TFT – LCD module in direct sunlight
- (3) The module should be stored in dark place. It is prohibited to apply sunlight or fluorescent light in storing

### 9.3 OPERATION PRECAUTIONS

- (1) The LCD product should be operated under normal condition.  
Normal condition is defined as below :  
Temperature : 20±15°C  
Humidity: 65±20%  
Display pattern : continually changing pattern(Not stationary)
- (2) If the product will be used in extreme conditions such as high temperature, high humidity, high altitude, display pattern or operation time etc... It is strongly recommended to contact CMI for application engineering advice. Otherwise, its reliability and function may not be guaranteed.

### 9.4 SAFETY PRECAUTIONS

- (1) If the liquid crystal material leaks from the panel, it should be kept away from the eyes or mouth. In case of contact with hands, skin or clothes, it has to be washed away thoroughly with soap.
- (2) After the module's end of life, it is not harmful in case of normal operation and storage.

### 9. INSPECTION SPECIFICATION

**1. SCOPE SPECIFICATIONS CONTAIN**

- 1.1 DISPLAY QUALITY EVALUATION
- 1.2 MECHANICS SPECIFICATION

**2. SAMPLING PLAN**

UNLESS THERE IS OTHER AGREEMENT, THE SAMPLING PLAN FOR INCOMING INSPECTION SHALL FOLLOW MIL-STD-105E.

- 2.1 LOT SIZE: QUANTITY PER SHIPMENT AS ONE LOT (DIFFERENT MODEL AS DIFFERENT LOT ).
- 2.2 SAMPLING TYPE: NORMAL INSPECTION, SINGLE SAMPLING.
- 2.3 SAMPLING LEVEL: LEVEL II.
- 2.4 AQL: ACCEPTABLE QUALITY LEVEL  
 MAJOR DEFECT: AQL=0.65  
 MINOR DEFECT: AQL=1.0

**3. PANEL INSPECTION CONDITION**

- 3.1 ENVIRONMENT:  
 ROOM TEMPERATURE: 25±5°C.  
 HUMIDITY: 65±5% RH.  
 ILLUMINATION: 300 ~ 700 LUX.
- 3.2 INSPECTION DISTANCE:  
 35±5 CM
- 3.3 INSPECTION ANGLE:  
 THE VISION OF INSPECTOR SHOULD BE PERPENDICULAR TO THE SURFACE OF THE MODULE.
- 3.4 INSPECTION TIME:  
 PERCEPTIBILITY TEST TIME: 20 SECONDS MAX.

**4. DISPLAY QUALITY**

- 4.1 FUNCTION RELATED:  
 THE FUNCTION DEFECTS OF LINE DEFECT, ABNORMAL DISPLAY, AND NO DISPLAY ARE CONSIDERED MAJOR DEFECTS.
- 4.2 BRIGHT/DARK DOTS:

Defect Type	Specification	Major	Minor
Bright Dots	$N \leq 2$		●
Dark Dots	$N \leq 3$		●
Total Bright and Dark Dots	$N \leq 4$		●

Note 1:

The definition of dot: The size of a defective dot over 1/2 of whole dot is regarded as one defective dot.

Bright dot: Dots appear bright and unchanged in size in which LCD panel is displaying under black pattern.

The bright dot defect must be visible through 2% ND filter

Dark dot: Dots appear dark and unchanged in size in which LCD panel is displaying under pure red, green, blue pattern.

4.3 Pixel Definition:

R	G	B	R	G	B	R	G	B		Dot Defect
R	G	B	R	G	B	R	G	B		Adjacent Dot Defect
R	G	B	R	G	B	R	G	B		Cluster

Note 1:

If pixel or partial sub-pixel defects exceed 50% of the affected pixel or sub-pixel area, it shall be considered as 1 defect.

Note 2:

There should be no distinct non-uniformity visible through 2% ND Filter within 2 sec inspection times.

4.4 Visual Inspection specifications:

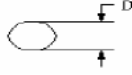
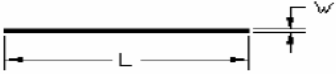
<u>Defect Type</u>		<u>Specification Size</u>	<u>Count(N)</u>	Major	Minor
Dot Shape (Particle · Scratch and Bubbles in display area) 		$D \leq 0.25 \text{ mm}$	Ignored		•
		$0.25\text{mm} < D \leq 0.5\text{mm}$	$N \leq 3$		
		$D > 0.5\text{mm}$	$N=0$		
Newton Ring (Only for Touch panel)		$D \leq 70\text{mm}$	$N \leq 4$		•
		$D > 70\text{mm}$	$N=0$		
TSP Fish Eyes (Only for Touch panel) (Bubble/Dent)		$0.1\text{mm} < D \leq 0.2\text{mm}$	$N \leq 4$		•
		$0.2\text{mm} < D \leq 0.3\text{mm}$	$N \leq 3$		
		$0.3 < D \leq 0.4$	$N \leq 2$		
Line Shape (Particles · Scratch · Lint and Bubbles in display area) 		$W \leq 0.01 \text{ mm}$	Ignored		•
		$0.01\text{mm} < W \leq 0.05\text{mm}$ and $L \leq 3\text{mm}$	$N \leq 3$		
		$W > 0.05\text{mm}$ or $L > 3 \text{ mm}$	$N=0$		
Bubble in cell (active area)		It should be found by eyes			•
Bezel	Scratch	No harm			•
	Dirt				•
	Wrap				•
	Sunken				•
Label	No label	No			•
	Inverted label				•
	Broken				•
	Dirt	Word can be read.			•
	Not clear	No			•
	Word out of shape				•
	Mistake	No			•
	Position	Be attached on right position			•
Screw	Not enough	No			•
	Limp	No			•

Connector	Connection status	No bend on pins and damage		•
FPC/FFC	Broken	No		•

Note: Extraneous substance and scratch not affecting the display of image, for instance, extraneous substance under polarizer film but outside the display area, or scratch on metal bezel and backlight module or polarizer film outside the display area, shall not be considered as defective or non-conforming.