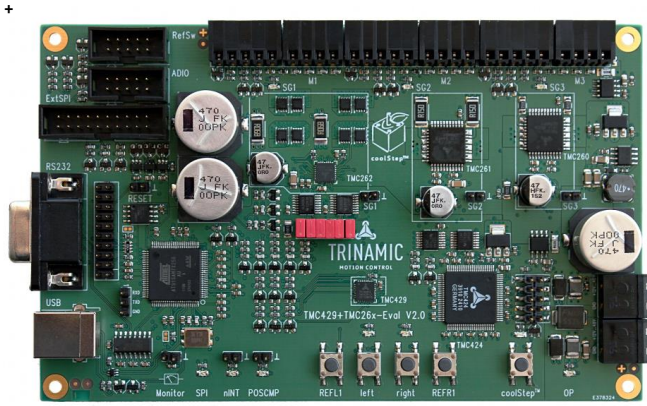

Firmware Version V2.04

TMC429+TMC26x EVALUATION BOARD MANUAL

**TMC429+TMC26x-EVAL**

Evaluation Board for
 TMC429 Motion Controller and
 TMC262, TMC261, and TMC260
 Stepper Motor Driver ICs for
 Two Phase Stepper Motors
 Evaluation of TMC424 Incremental
 Encoder Interface Chip
 USB, RS232, Step/Dir
 SPI Access to Chips
 Reference Switches for Each Axis

UNIQUE FEATURES

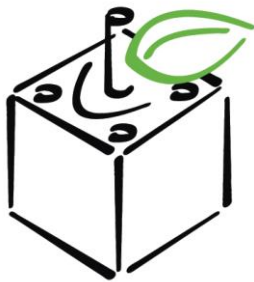

coolStep™

stallGuard2™

TABLE OF CONTENTS

1	Features.....	3
2	Order Codes	4
3	Mechanical and Electrical Interfacing	5
3.1	TMC429+TMC26x-EVAL Board Dimensions	5
3.2	Connectors & Keys	6
3.2.1	Power Connectors	8
3.2.2	RS232 Serial Communication Connector	9
3.2.3	USB Connector (USB-B)	9
3.2.4	Motor Connectors	9
3.2.5	Encoder Connectors	9
3.2.6	Step/Dir (StpDirS) Jumpers / Connectors (on-board).....	10
3.2.7	SPI Extender (ExtSPI)	11
3.2.8	Reference Switch Connector (RefSw).....	11
3.2.9	Analog and Digital Inputs and Outputs (ADIO)	12
4	Operational Ratings	13
5	Functional Description	14
5.1	System architecture.....	14
5.1.1	Microcontroller	14
6	Getting Started – How to Run a Motor	15
6.1	Standalone Operation.....	15
6.2	Evaluation Software Operation.....	15
7	Evaluation Software.....	16
7.1	Interface	17
7.1.1	Installing Virtual COM port for USB	17
7.1.2	Physical RS232	19
7.2	Start Window.....	20
7.3	Advanced.....	22
8	TMCL	31
8.1	Communicating with PC.....	31
8.1.1	Binary Command Format	31
8.1.2	Reply Format.....	32
8.1.3	Direct Register Access	32
9	Life Support Policy	33
10	Revision History	34
10.1	Document Revision	34
10.2	Hardware Revision	34
10.3	Firmware Revision.....	35
10.4	Software Revision (PC Application Software Revision).....	35
11	References.....	35

1 Features

This evaluation board is for evaluation of the motion controller TMC429, for the stepper motor drivers TMC262, TMC261, TMC260, and for the incremental encoder interface chip TMC424.

MAIN CHARACTERISTICS

Applications

- motion control application without encoder
- motion control applications with encoder

Electrical data

- Supply voltage: common supply voltages +12VDC / +24VDC / +48VDC (TMC261 only)
Programmable motor current up to 3.0A RMS resp. 1.4 RMS (M1 : 4.3A peak, M2 : 2A peak, M3 : 2A peak)

Integrated encoder interface (TMC424)

- Integrated interfaces for three incremental encoders (ABN)

Integrated bipolar stepper motor drivers (based on TMC262, TMC261, TMC260)

- Up to 256 micro steps per full step
- Dynamic current control
- Integrated protection
- High precision sensorless motor load measurement stallGuard2™
- Automatic load dependent motor current adaptation for reduced power consumption and heat dissipation (coolStep™)

Interfaces

- USB (USB-B), RS232
- Step/Direction
- SPI™
- reference switch inputs
- ABN encoder inputs

Software

- TMCL™ & PC-Software
- stand-alone operation or remote controlled operation
- program memory (non volatile) for up to 2048 TMCL commands
- PC-based application development software TMCL-IDE available for free
- PC-based stand-alone evaluation software available for free

TRINAMICS UNIQUE FEATURES

stallGuard2™ stallGuard2 is a high-precision sensorless load measurement using the back EMF on the coils. It can be used for stall detection as well as other uses at loads below those which stall the motor. The stallGuard2 measurement value changes linearly over a wide range of load, velocity, and current settings. At maximum motor load, the value goes to zero or near to zero. This is the most energy-efficient point of operation for the motor.

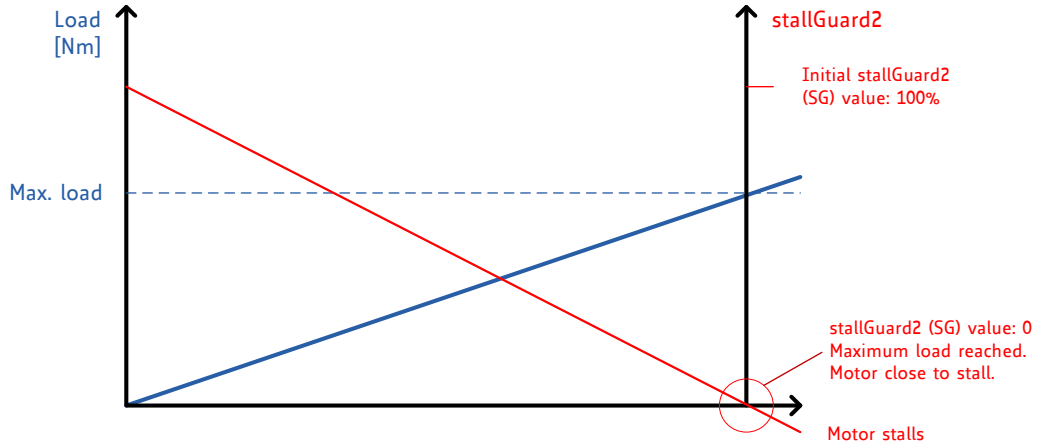

Figure 1.1 stallGuard2 load measurement SG as a function of load

coolStep™ coolStep is a load-adaptive automatic current scaling based on the load measurement via stallGuard2 adapting the required current to the load. Energy consumption can be reduced by as much as 75%. coolStep allows substantial energy savings, especially for motors which see varying loads or operate at a high duty cycle. Because a stepper motor application needs to work with a torque reserve of 30% to 50%, even a constant-load application allows significant energy savings because coolStep automatically enables torque reserve when required. Reducing power consumption keeps the system cooler, increases motor life, and allows reducing cost.

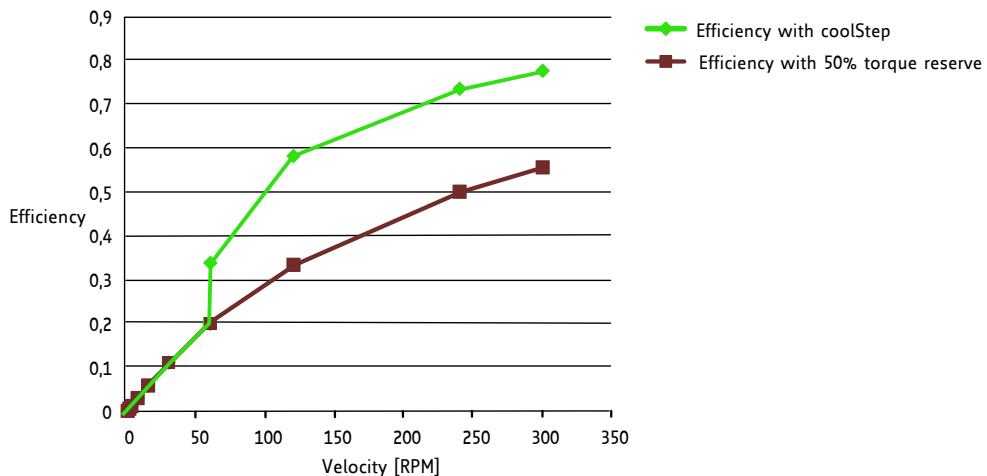

Figure 1.2 Energy efficiency example with coolStep

2 Order Codes

Order code	Description	Size of unit [mm ²]
TMC429+TMC26x-EVAL	Evaluation board for TMC429 motion controller and TMC262, TMC261, TMC260, and TMC424.	160 x 100

Table 2.1 Order codes

3 Mechanical and Electrical Interfacing

3.1 TMC429+TMC26x-EVAL Board Dimensions

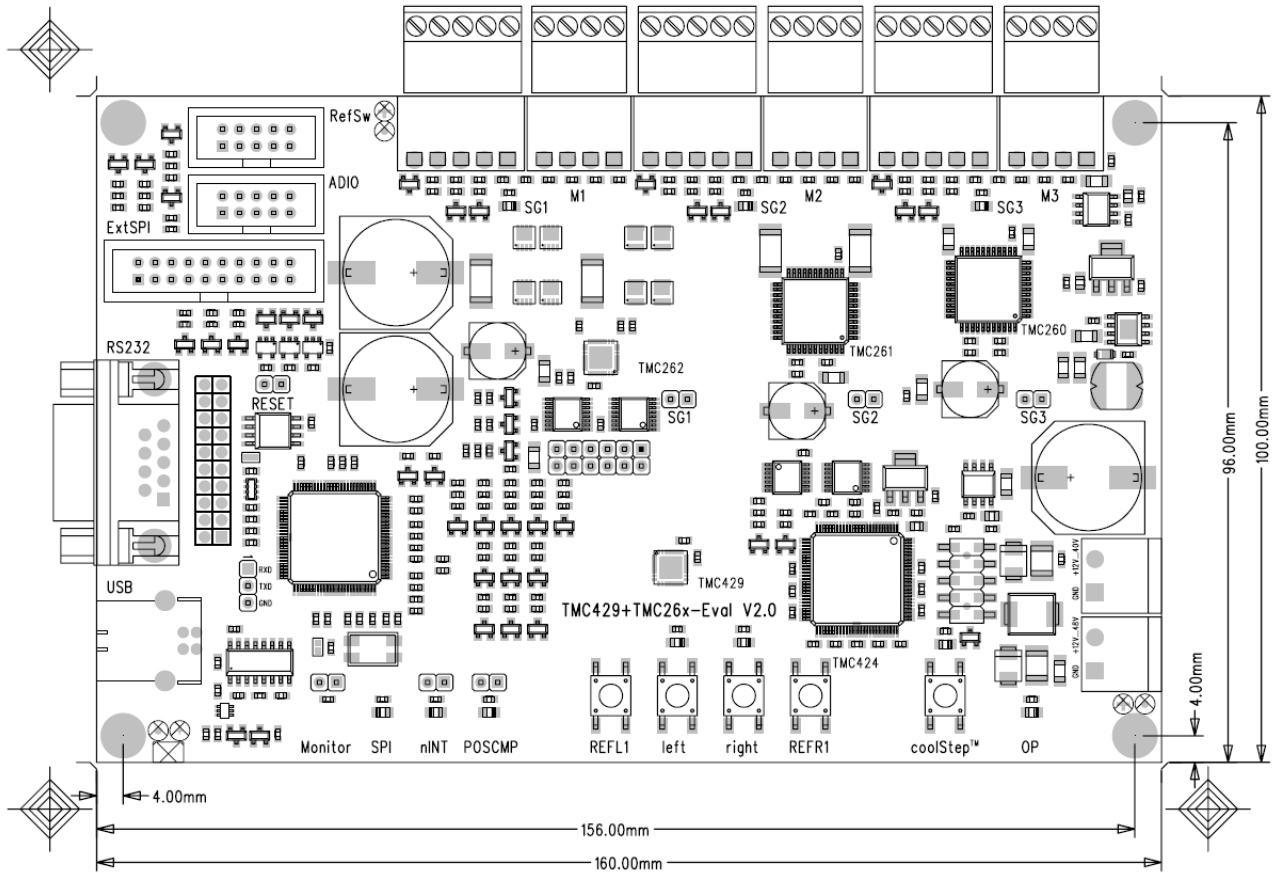

Figure 3.1 Dimensions of TMC429+TMC26x Evaluation Board

3.2 Connectors & Keys

The TMC429 evaluation board v.1.1 is for evaluation of the TMC429 motion controller, the stepper motor drivers TMC260 and TMC261, and TMC424 triple encoder interface. The board offers 3 connectors for up to three stepper motors, three connectors for up to three incremental encoders (ABN), USB-B, RS232, power supply connectors. Additionally, the board is equipped with reference switch inputs, analog and digital general purpose IOs to interface external components as electric brake or torque sensor. An additional analog provides a direct interface to a multi-meter. Dedicated outputs of the TMC429 (nINT and POSCMP) are directly available via jumper connectors. Internal SPI signals resp. Step-Direction signals between TMC429 and the stepper motor drivers TMC260 / TMC261 are available at a jumper field. With this, one can feed these signals to external drivers or can use externally generated signals. So, with this one can evaluate the the TMC429 and the stepper motor drivers TMC260 / TMC261 separately.

The board is equipped with some keys for stand-alone operation. The left and right key turns the stepper motor number one left (negative direction) or right (positive). Two reference switches can be simulated via REFL1 (left reference switch of motor 1) and REFR1 (right reference switch of motor 1). The switch coolStep™ switches the coolStep™ function on/off. LEDs on the board indicate that the board is powered and if coolStep™ is switched on or off.

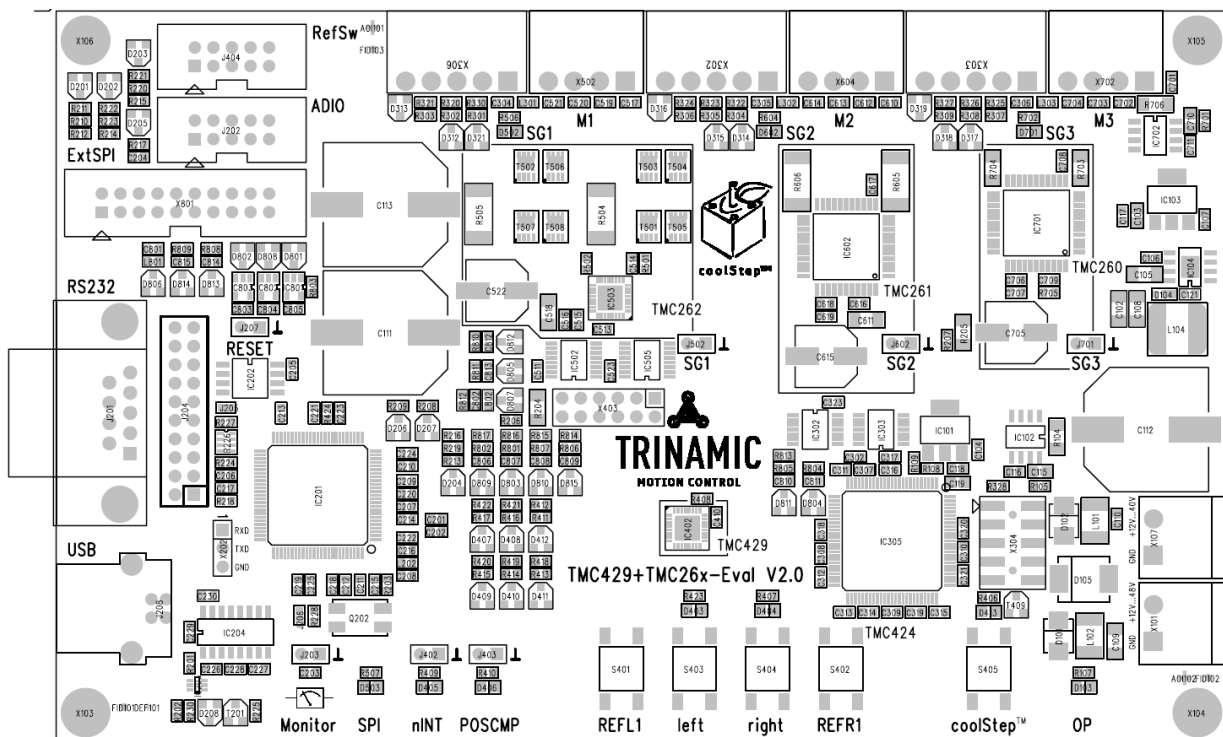

Figure 3.2 Connectors of TMC429+TMC26x Evaluation Board

Key	Label	Description
S401	REFL1	left reference switch for stepper motor number one
S403	left	move left, move into negative direction, cw/ccw depends on motor
S404	right	move right, move into positive direction, cw/ccw depends on motor
S402	REFR1	right reference switch for stepper motor number one
S405	coolStep™	switch on/off the coolStep™ function

Table 3.1 Key overview

Connector	Label	Description
X107	Power40V	standard power supply 12V ... 40V for the TMC262, TMC260, and TMC261
X101	Power48V	additional power supply for up to 48V for the TMC261
X403	StpDirS	step and direction signals between TMC429 and TMC26x drivers
X306	Encoder1	ABN encoder inputs for motor #1
X502	Motor1	stepper motor #1
X302	Encoder2	ABN encoder inputs for motor #2
X604	Motor2	stepper motor #2
X303	Encoder3	ABN encoder inputs for motor #3
X702	Motor3	stepper motor 3
J203	Monitor	output for analog meter (MTR) for visualization of stallGuard™ and coolStep™
J402	nINT	low active interrupt output of the TMC429
J403	POSCMP	POSCMP output of the TMC429
J208	USB-B	USB-B connector at the board for USB-A connector cable to PC
J201	RS232	RS232 connector to PC with +/-12V level
X202	DEBUG	RxD and TxD with 3.3V logic level (UART) (link these pins for a special SPI mode, where the CPU still provides the CLK signals)
J204	JTAG	JTAG programming adapter for the ARM micro controller
J207	RESET	Reset of the ARM micro controller to completely disable it for external control via ExtSPI
X801	ExtSPI	external SPI connector for customer to control drivers by external SPI signals
J202	ADIO	general purpose analog and digital IOs
J404	RefSw	reference switch inputs for the TMC429
J502	SG1	stallGuard™ output of motor driver 1 and ground pin
J602	SG2	stallGuard™ output of motor driver 2 and ground pin
J701	SG3	stallGuard™ output of motor driver 3 and ground pin

Table 3.2 Connector overview

The naming of the connectors is associated with the pages of the schematic.
Example: X107 (Power40V) is on page 1 of the schematic, X306 is on page 3 of the schematic.

Connector Type	Vendor, WWW, Type, Order Number
Power	Phoenix Contact, http://www.phoenixcontact.com/ , MSTB 2,5/ 2-ST-5,08, 2 way
Motor	RIA-CON, http://www.ria-connect.net/en/home , Type 169 (small), 4 way, 311 691 04
Encoder	RIA-CON, http://www.ria-connect.net/en/home , Type 169 (small), 5 way, 311 691 05

Table 3.3 Connector types

3.2.1 Power Connectors

The evaluation board has two separate power supply connectors due to different stepper motor driver supply voltages (TMC260 and TMC262 vs. and TMC261). Internally, the Power48V is connected via a diode from the Power40V. So, for any power supply within range of 12V ... 40V a single voltage power supply is sufficient for the board.

When using supply voltages near the upper limit, a regulated power supply is mandatory. Please ensure that enough power filtering capacitors are available in the system (2200 μ F or more recommended) in order to absorb mechanical energy fed back by the motor in stalling conditions. In larger systems a suppressor diode circuitry might be required in order to limit the maximum voltage when the motor is operated at high velocities.

The power supply should be able to supply the nominal motor voltage at the desired maximum motor power. **In no case shall the supply value exceed the upper voltage limit.**

To ensure reliable operation of the unit, the power supply has to have a sufficient output capacitor and the supply cables should have a low resistance, so that the chopper operation does not lead to an increased power supply ripple directly at the unit. Power supply ripple due to the chopper operation should be kept at a maximum of a few 100mV.

GUIDELINES FOR POWER SUPPLY

- Keep power supply cables as short as possible!
- Use large diameters for power supply cables!
- Add 2200 μ F or larger filter capacitors near the motor driver unit especially if the distance to the power supply is large (i.e. more than 2-3m)!

	Pin	Label	Description
	1	GND	power ground
2	+12V ... +40V	power supply up to 40V	

Table 3.4 Connector Power40V

When the higher voltage power supply is used, the 40V needs to be powered too.

	Pin	Label	Description
	1	GND	power ground
2	+12V ... +48V	power supply up to 48V	

Table 3.5 Connector (additional) Power48V for TMC261

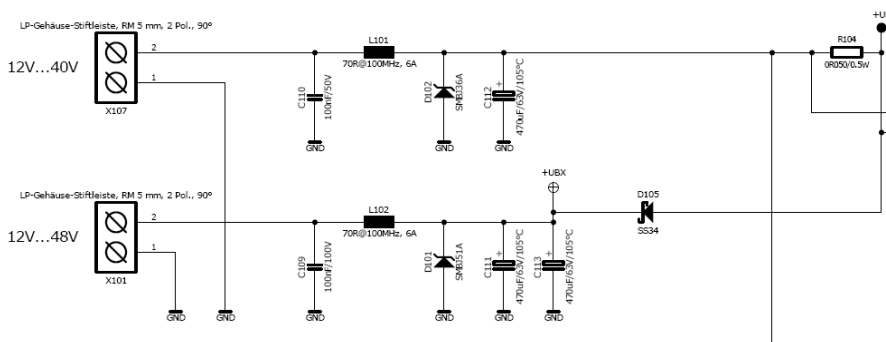

Figure 3.3 Power connectors scheme (Power40V & Power48V)

3.2.2 RS232 Serial Communication Connector

The module supports RS232 and USB communication over this connector. For communication via RS232 a cable with metal connectors is required. The board is equipped with a male RS232 connector. For RS232 connection with a PC an extension cable is required (cable with one side female connector and the other side with a male connector with pins 2, 3, 5 connected).

	Pin	Label	Description
	1	-	
	2	TxD	
	3	RxD	
	4	-	
	5	-	signal ground, not connected on PCB, fixed by a hookup-wire (for plastic "shield" cables)
	6	-	
	7	-	
	8	-	
	9	-	
	10, 11	GND	ground, shield

Table 3.6 Connector for serial communication

3.2.3 USB Connector (USB-B)

A 4-pin standard USB-B connector is available on board.

	Pin	Label	Description
	1	VBUS	+5V power
	2	D-	Data -
	3	D+	Data +
	4	GND	Ground

Table 3.7 USB-B connector

3.2.4 Motor Connectors

	Pin	Label	Description
	1	OA1	Motor coil A
	2	OA2	Motor coil A
	3	OB1	Motor coil B
	4	OB2	Motor coil B

Table 3.8 Connector for Step/Dir signals

3.2.5 Encoder Connectors

	Pin	Label	Description
	1	+5V	+5V supply for encoder
	2	A	A input (with pull-up R on board)
	3	B	B input (with pull-up R on board)
	4	N	N input (with pull-up R on board)
	5	GND	ground

Table 3.9 Connector for ABN incremental encoder

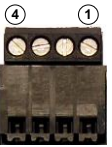
3.2.6 Step/Dir (StpDirS) Jumpers / Connectors (on-board)

	Pin	Label	Description
	1	nSCS3_D3	TMC429 DIR output D3 (square Pad)
	2	DIR_3	TMC26x DIR_3 input
	3	nSCS2_S3	TMC429 step output S3
	4	STEP_3	TMC26x STEP_3 input
	5	nSCS_S_S2	TMC429 step output S2
	6	STEP_2	TMC26x STEP_2 input
	7	SDI_S_D2	TMC429 DIR output D2
	8	DIR_2	TMC26x DIR_2 input
	9	SDO_S_S1	TMC429 step output S1
	10	STEP_1	TMC26x STEP_1 input
	11	SCK_S_D1	TMC429 DIR output D1
	12	DIR_1	TMC26x DIR_1 input

Table 3.10 Step/Dir jumper / connector

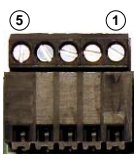
For standalone operation of the board with TMC429 with step/direction mode, the jumper pins need to be connected as by six jumpers (1-2, 3-4, 5-6, 7-8, 9-10, 11-12). Please refer Figure 3.4.

For external step/direction control of the drivers, the jumpers have to be disconnected and the even numbered pins (2, 4, ...) can be used as connectors.

Pin 1 is identified by a square pad at the bottom side (soldering side) of the board - the other pads are circular.

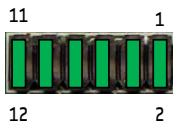

Figure 3.4 StpDirS on-board connection scheme for standalone operation

3.2.7 SPI Extender (ExtSPI)

The SPI external connector can be used to connect the TMC26x drivers with external motion controllers, microcontrollers with additional software, or step pulse generators. Please refer to the circuit diagram, too. The SPI external connector is component x403.

	Pin	Label	Description
	1	MISO	Master In Slave Out
	2	+3.3V	+3.3V voltage supply
	3	SCK	SPI clock
	4	MOSI	Mater Out Slave In
	5	GND	ground
	6	GND	ground
	7	nCS_429	nCS_C (chip select) signal of the TMC429
	8	CLK_429	CLK feed to TMC429 via multiplexer
	9	nCS_DRV1	CSN of driver 1
	10	SPI_SEL	SPI selection signal
	11	nCS_DRV2	CSN of driver 2
	12	CS_SEL	chip select signal (pls. refer schematic)
	13	nCS_DRV3	CSN of driver 3
	14	CLK_DRV	clock for the stepper motor drivers
	15	nCS_CON	not Chip Select CONector
	16	GND	ground
	17	nCS_424	nCS of TMC424
	18	GND	ground
	19	nRES_424	reset signal for the TMC424
	20	CLK_424	clock for the TMC424

Table 3.11 SPI extender / connector

Before connecting an external SPI device, bridge pins RXD and TXD of the debug RS232 connector X202 to switch off the microcontroller SPI interface. This will leave on the CPU. The CPU in this mode still provides a clock signal to the TMC429, 26x and 424.

3.2.8 Reference Switch Connector (RefSw)

	Pin	Label	Description
	1	+5V	+5V supply voltage
	2	GND	ground
	3	REF1	reference switch input REF1 of TMC429
	4	REFR1	reference switch input REFR1 of TMC429
	5	REF2	reference switch input REF2 of TMC429
	6	REFR2	reference switch input REFR2 of TMC429
	7	REF3	reference switch input REF3 of TMC429
	8	REFR3	reference switch input REFR3 of TMC429
	9	GND	ground
10	+3.3V	+3.3V supply voltage	

Table 3.12 Step-Direction jumper / connector

3.2.9 Analog and Digital Inputs and Outputs (ADIO)

These IOs might be renamed later when the firmware of the TMC429 evaluation board will process these with dedicated functions.

	Pin	Label	Description
	1	A0	analog input of μ C (A0)
	2	GND	ground
	3	+5V	+5V supply voltage
	4	A3	analog input of μ C (A3)
	5	PWM1	analog output via PWM on PWM1 of μ C
	6	A2	analog input of μ C (A2)
	7	PB24	digital IO of μ C
	8	A1	analog input of μ C (A1)
	9	PB25	digital IO of μ C (PB25)
10	+3.3V	+3.3V supply voltage	

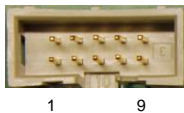
Table 3.13 Analog and Digital Inputs and Outputs (ADIO)

4 Operational Ratings

The operational ratings shown below should be used as design values. *In no case should the maximum values been exceeded during operation!*

The maximum power supply current need depends on the used motors and the supply voltage.

Symbol	Parameter	Min	Typ	Max	Unit
V12V40	Power supply voltage for operation	12	12, 24	40	V
V12V48	Power supply voltage for operation	12	12, 24, 48	48	V
I _{COIL_RMS_tm262}	Continuous motor 1 current (RMS)	0.10		3.02	A
I _{COIL_RMS_tm261}	Continuous motor 2 current (RMS)	0.05		1.37	A
I _{COIL_RMS_tm260}	Continuous motor 3 current (RMS)	0.05		1.37	A
I _{SUPPLY}	Power supply current	0.05		6	A
T _{ENV}	Environment temperature at rated current (no forced cooling required)		tbd		°C

Table 4.1 General operational ratings of the module

Symbol	Parameter	Min	Type	Max	Unit
V _{REFSWT}	Input voltage for reference switches	0		5	V
V _{ABN_INPUTS}	ABN incremental encoder inputs	0		5	V
V _{ABN_SUPPLY}	supply voltage for ABN encoders		5		V
I _{ABN_SUPPLY}	supply current for ABN encoders			3 * 100	mA

Table 4.2 Operational ratings of IO signals

5 Functional Description

In Figure 5.1 the main parts of the TMC429 evaluation board are shown. The evaluation board is equipped with a μC with an additional flash memory for later functions, TMC429 motion controller, TMC424 encoder interface, and stepper motor drivers. The TMC262 and TMC260 stepper motor driver are for up to 40V supply voltage, the TMC261 stepper motor driver is for up to 48V supply voltage.

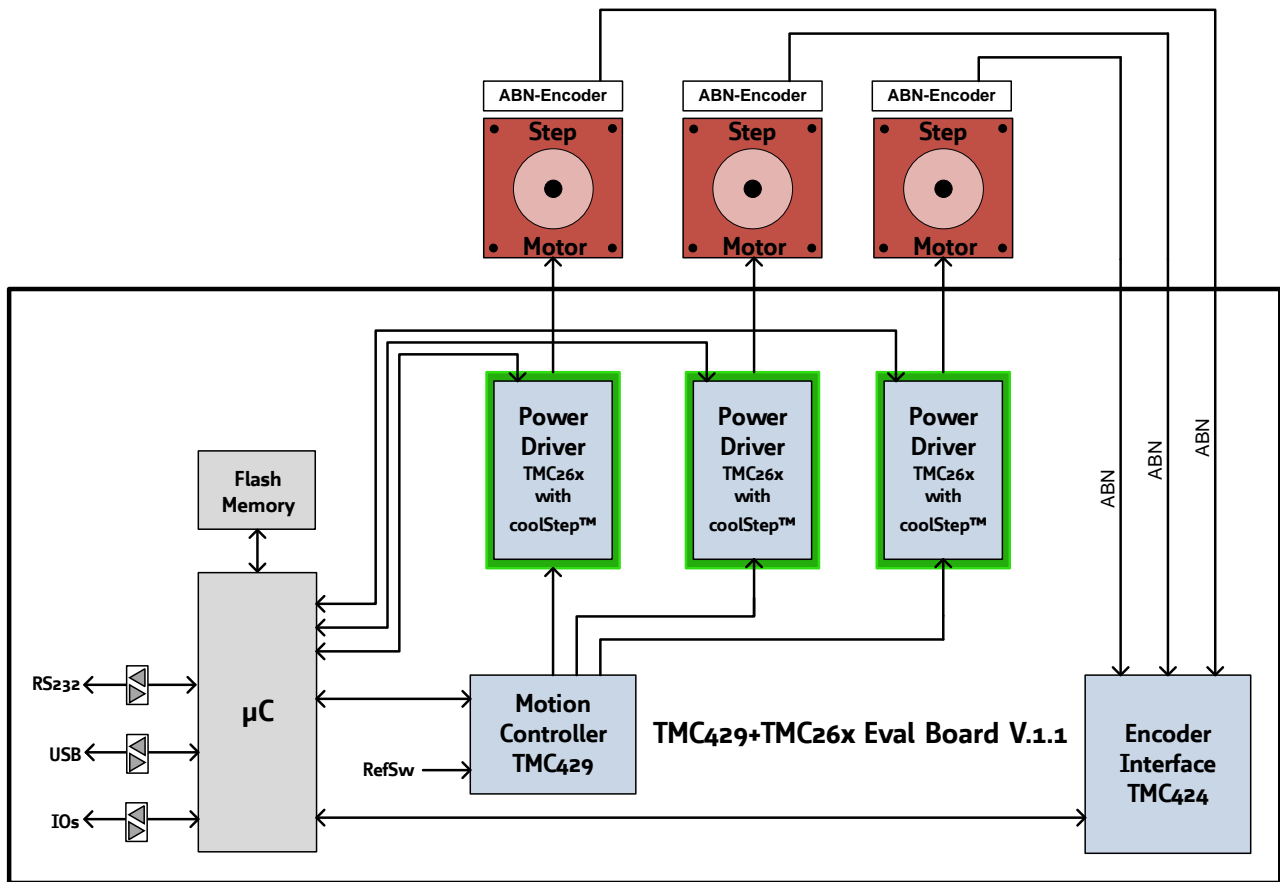

Figure 5.1 Functional block diagram of the TMC429 Evaluation Board V.1.1

5.1 System architecture

The evaluation board supports the TMCL (TRINAMIC Motion Control Language) and a standalone version for direct register access.

5.1.1 Microcontroller

On the evaluation board the Atmel AT91SAM7X256 is used to run the TMCL firmware and for the evaluation software. The CPU has 256KB flash memory and a 64KB RAM. The microcontroller runs the TMCL (TRINAMIC Motion Control Language) operating system which makes it possible to execute TMCL commands that are sent to the module from the host via the RS232 or USB.

The flash ROM of the microcontroller holds the TMCL operating system and firmware for direct register access to TMC429 / TMC260 / TMC261. The TMCL operating system can be updated via RS232 or USB. Use the TMCL-IDE to do this.

6 Getting Started – How to Run a Motor

ATTENTION: NEVER CONNECT OR DISCONNECT A MOTOR WHILE IT IS POWERED OR TURNING!

Connecting or disconnecting a motor while current flowing through a coil of the motor might damage the motor driver due to inductive high-voltage – no matter if the motor is at reset or turning. Turning a motor induces a voltage called Back-EMF (back electromagnetic force). Turning a motor externally (e.g. by a spring or flywheel mass) drives currents through the coils of the motor and this causes inductive high-voltage while connecting or disconnecting that might damage a motor driver.

6.1 Standalone Operation

To run a stepper motor, connect a stepper motor to connector M1. Then connect the power supply to connector **Power40V** with a supply voltage in range 12V to 40V. Then push and hold key left or push key right on the evaluation board to accelerate or decelerate the motor.

For the evaluation board, the motor currents are initialized for motor #1 with 0,856A (RMS) and for motor #2 and motor #3 for 0,388A (RMS).

Hint: The six StpDir jumpers need to be set (pls. refer Figure 3.4, page 10).

6.2 Evaluation Software Operation

To run a stepper motor, connect a stepper motor to connector M1. Then connect the power supply to connector **Power40V** with a supply voltage in range 12V to 40V.

Then connect either the RS232 or the USB from PC to computer. If you connect the USB first time, you will be asked for the virtual com port configuration file that is required for configuration of a virtual com port.

For Windows 2000 Systems use the INF file TMC429+TMC26x-EVAL_32bit_only.inf configuration file. For newer Windows systems use the TMC429+TMC26x-EVAL.inf configuration file.

Then start the TMC429+TMC26x-EVAL.exe software and follow section 7 Evaluation Software, page 16.

7 Evaluation Software

The stand-alone version of the evaluation software is intended for customers who design own PCBs with TMC429, TMC262, TMC261, TMC262, or TMC424. The stand-alone version of the evaluation software allows direct register access.

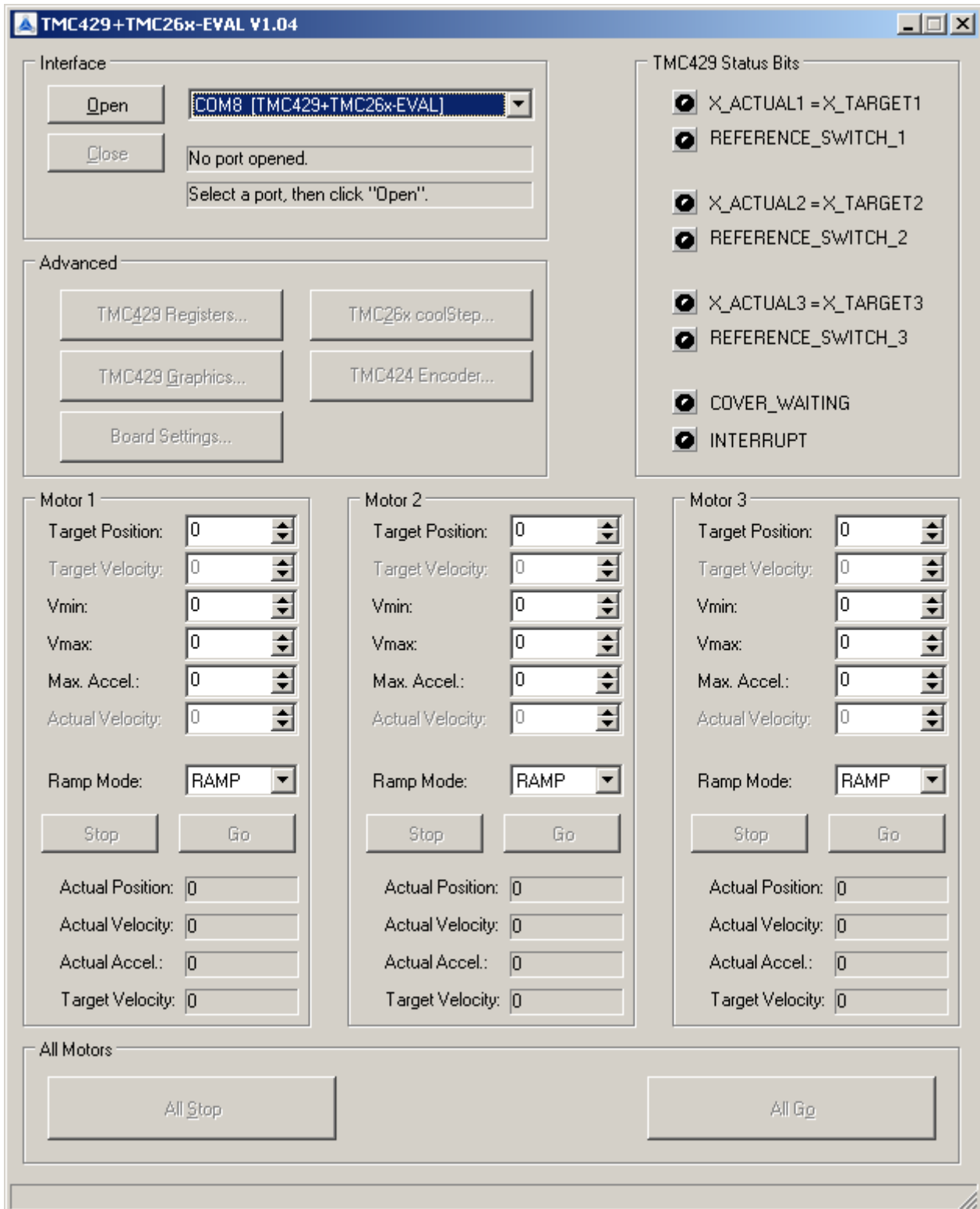

7.1 Interface

First, the interface needs to be opened – a COM port either a physical COM port via RS232 or USB with via virtual COM port. To use a virtual COM port via USB, the virtual comport needs to be installed when the board is connected at first time.

7.1.1 Installing Virtual COM port for USB

The following installation needs to be done when the board is first connected to an USB port of the PC.

Select the Software from a List ...

For Windows 2000 Systems use the INF file TMC429+TMC26x-EVAL_32bit_only.inf configuration file. For newer Windows systems use the TMC429+TMC26x-EVAL.inf configuration file.



Search source to find the INF file ...

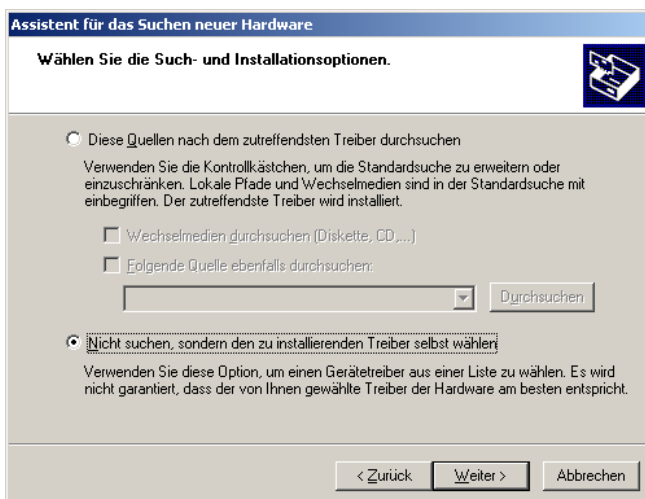

Push Continue (Weiter >) then you can select the INF file (driver) ...

Select the Trinamic TMC429+TMC26x-Eval (virtual COM) ... and push *continue* (Weiter >)

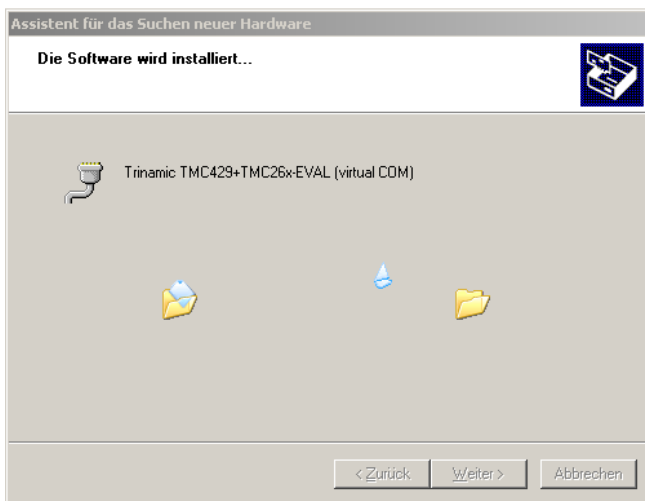

Then you will get a warning the the Windows-Logo-Test did not pass ...
Push *Continue Installation* (Installation fortsetzen) ...

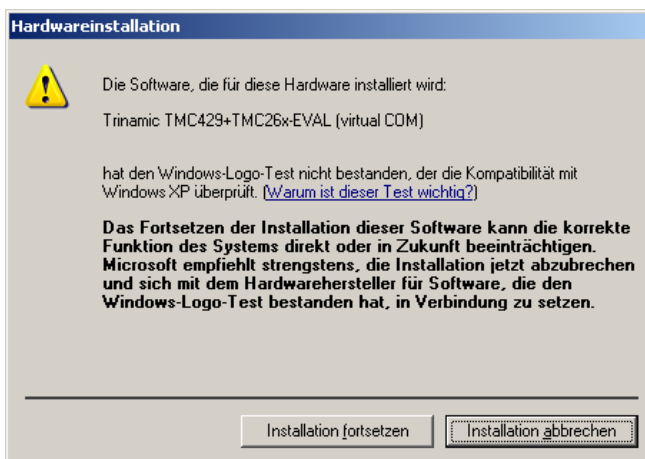

... and the installation continues ...

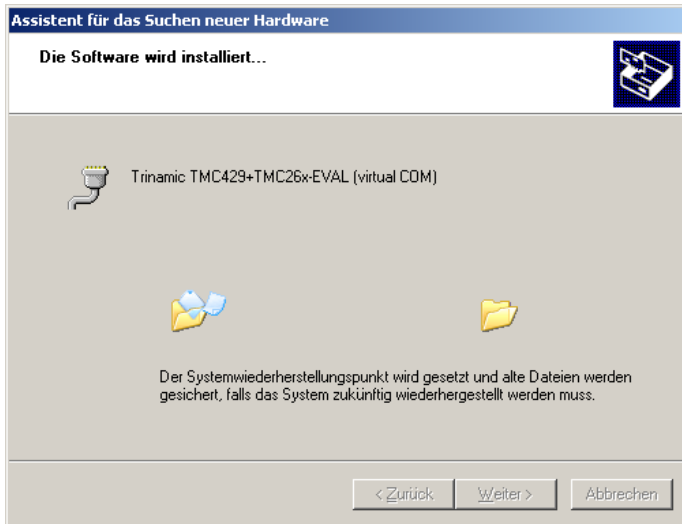

... when the software installation is done one finally needs to push *complete* (Fertig stellen) ...

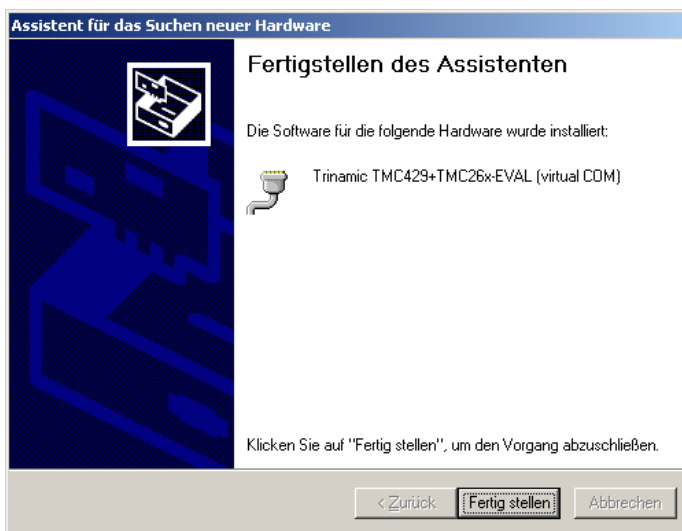

7.1.2 Physical RS232

When using a physical RS232 that is already available on the PC, there is no need for installation. The evaluation software itself sets the proper RS232 parameter (8N1, 38400 baud).

7.2 Start Window

The start window of the evaluation software allows turning motors with just a couple of parameters. First open the interface. To run Motor 1 to target position 9876, enter $V_{min}=1$, $V_{max}=1234$, Max. Accel = 567, Target Position = 9876 and push the button Go. Then the motor moves to position 9876 in Ramp Mode = RAMP (that is the power on default).

To turn motor 1 permanently, change the Ramp Mode = VELOCITY, set Target Velocity = 1234, acceleration Max. Accel = 567 and push the button Go. Then the motor runs permanently in velocity mode.

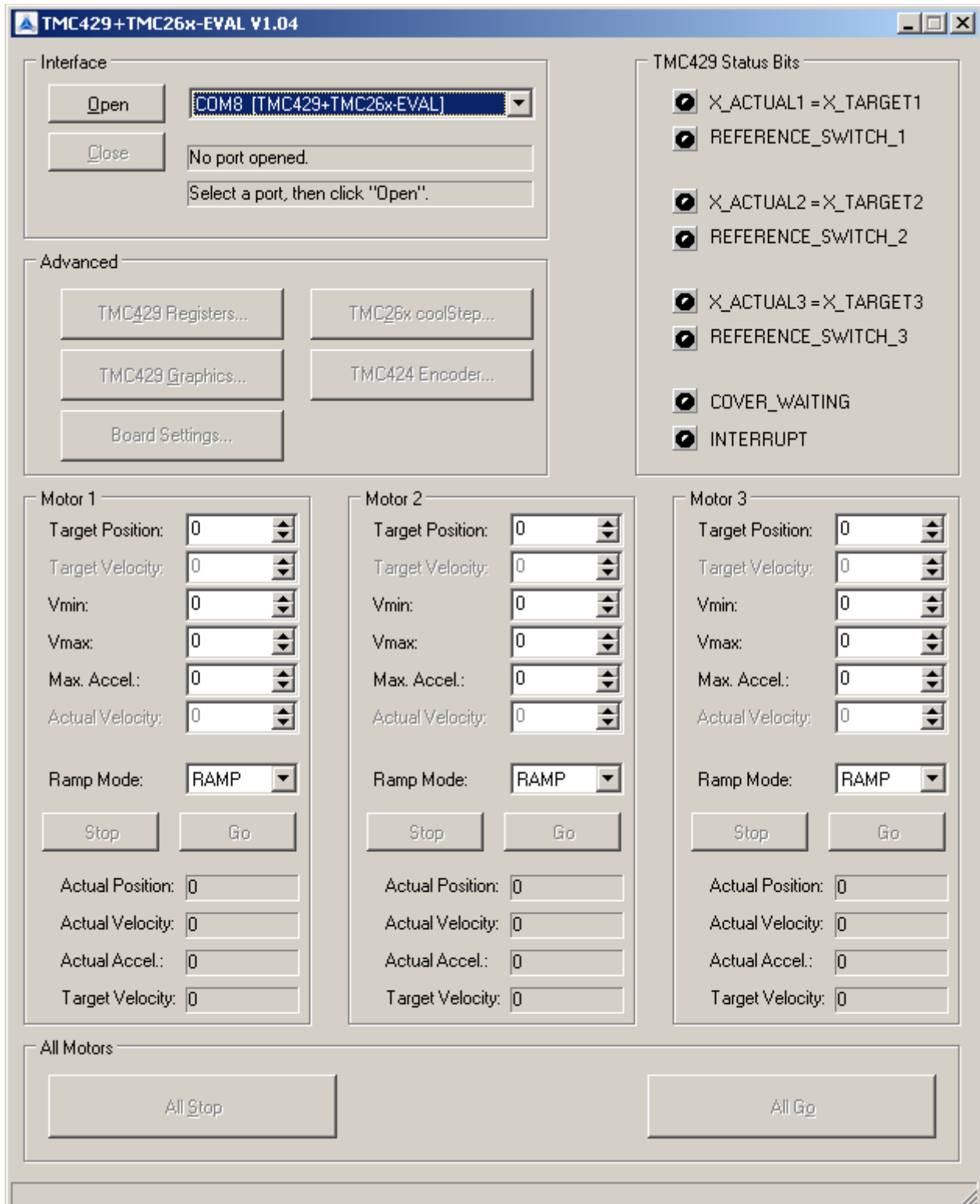

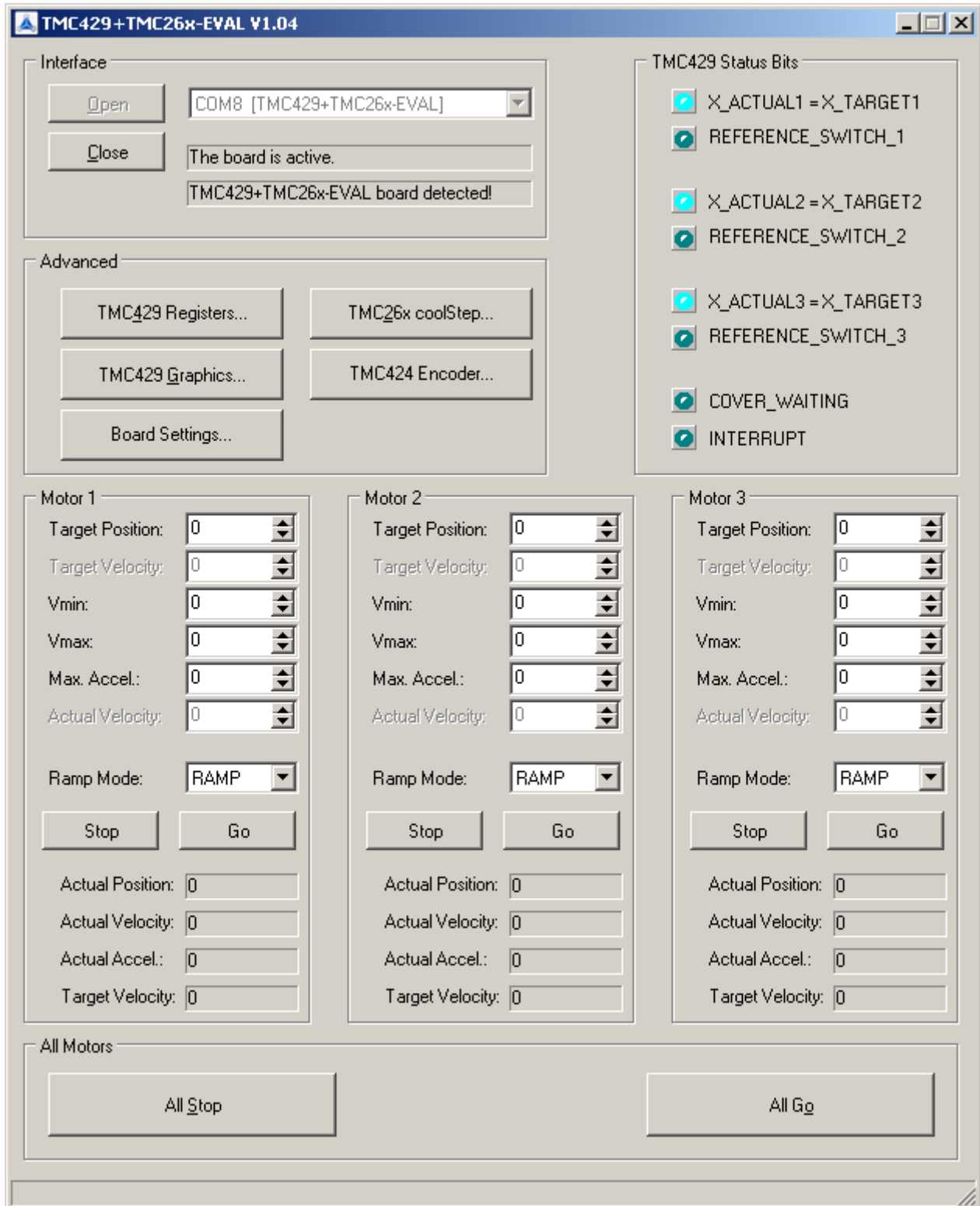

7.3 Advanced

Under *Advanced* the user finds five buttons:

- TMC429 Registers... : direct access to all registers of the TMC429 motion controller
- TMC26x coolStep... : direct access to all registers of the three drivers TMC262, TMC261, TMC260
- TMC429 Graphics... : graphics window for plotting of motion parameters (position, speed, acceleration)
- TMC424 Encoder... : direct access to all registers of the TMC424 encoder interface
- Board Settings... : enable and disable die drivers and some clock generation settings

From the button TMC429 Registers... one comes to the tab for direct access of all registers of the TMC429 motion controller. One sub-set of registers for each motor. These registers of the TMC429 are also available for its predecessor the TMC428. There is an additional tab for the additional registers of the TMC429 named "TMC429 Specials".

MOTOR 1

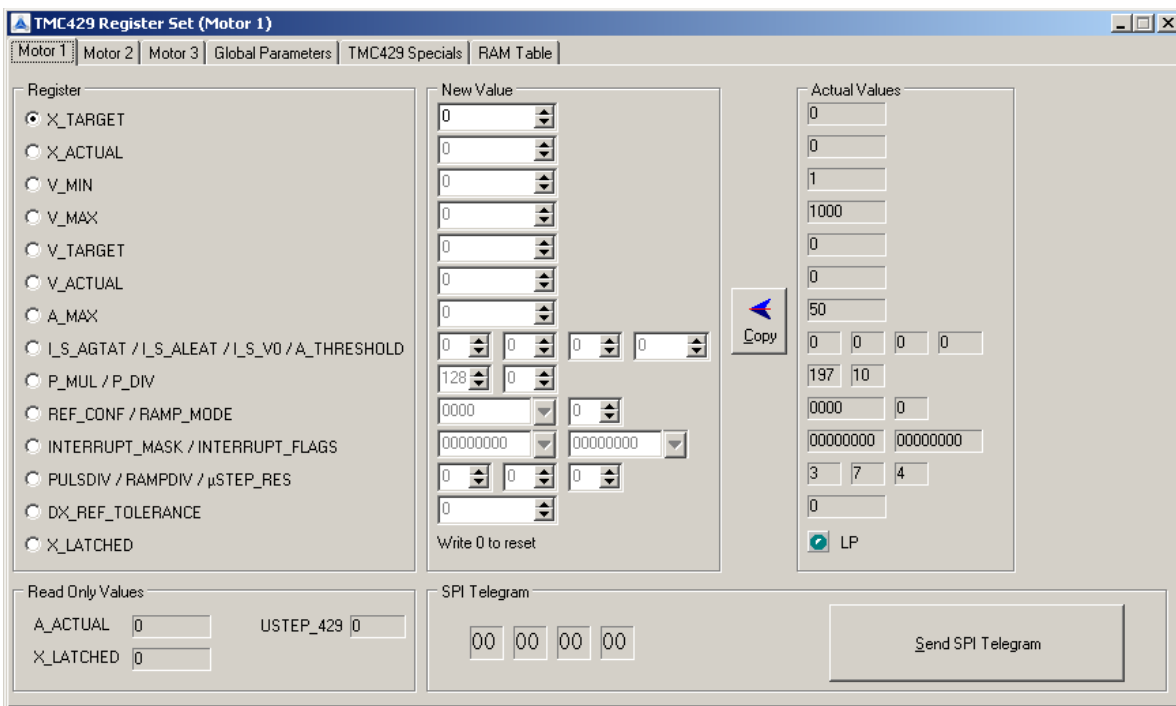

MOTOR 2

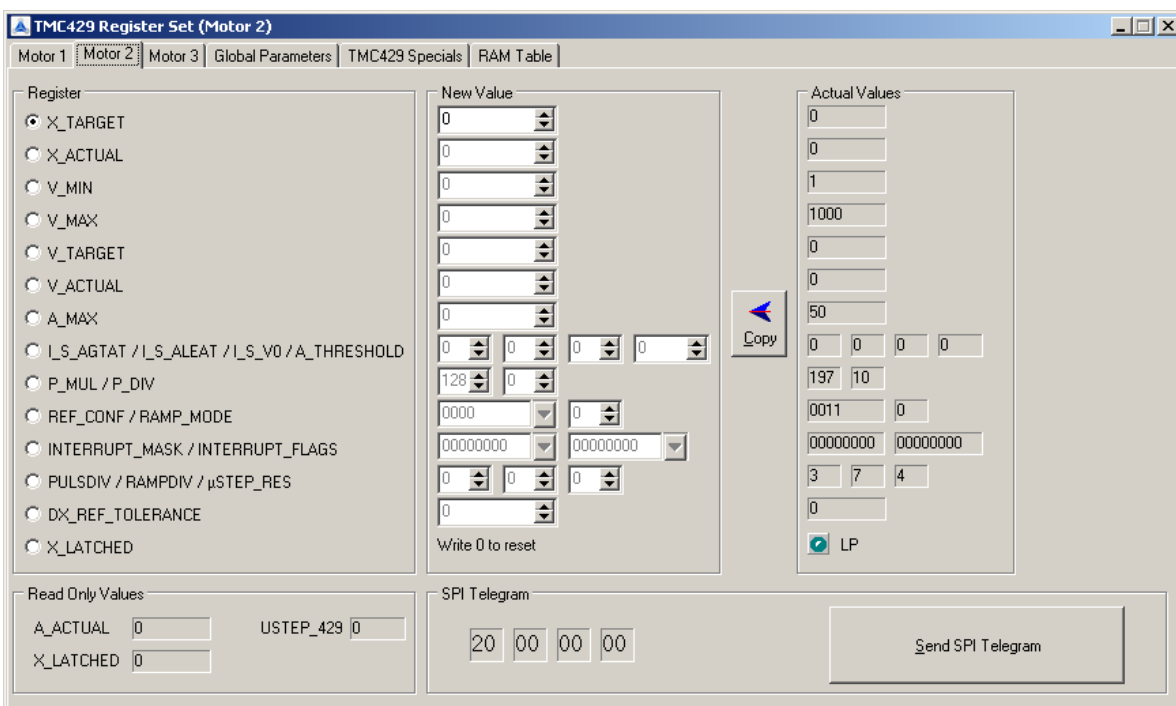

MOTOR 3

Please refer the TMC429 datasheet concerning the description of all registers of the TMC429 that is available on www.trinamic.com

The tab Global Parameters represents global settings of the TMC429

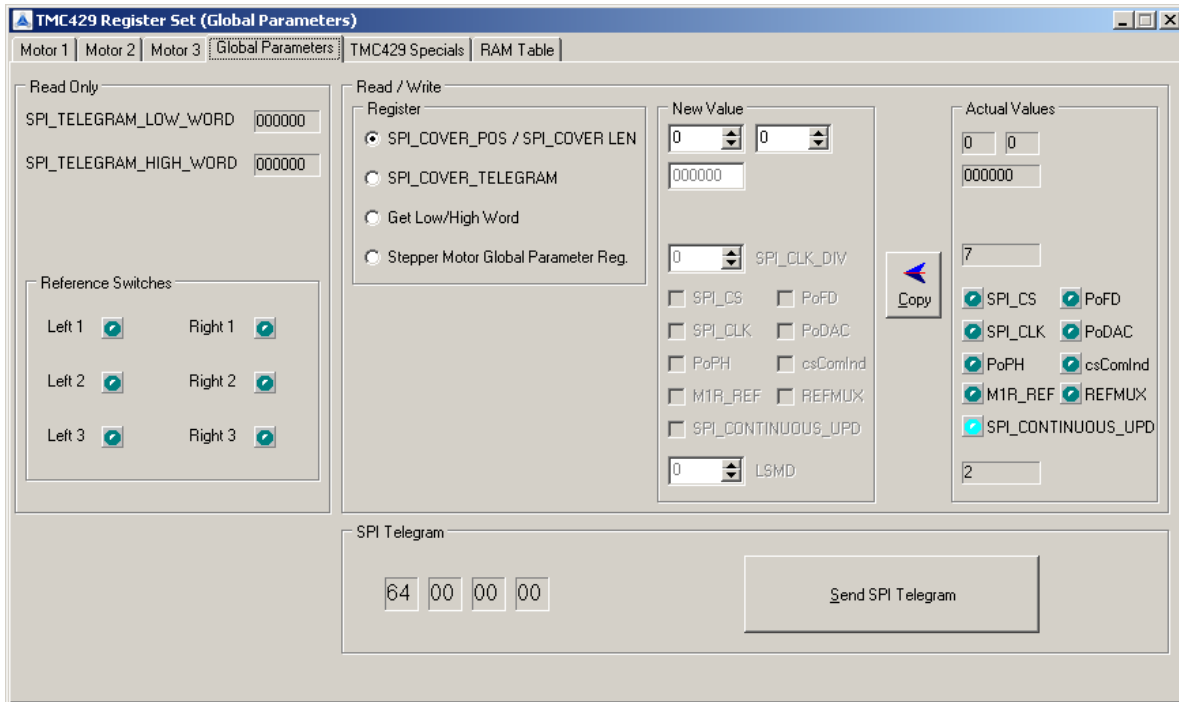

The tab TMC429 Specials holds that kind of registers of the TMC429 that are not available for the TMC428. The additional registers of the TMC429 are marked by **_429**.

The **pos_comp_429** register holds a position for compare with one of three motors position registers (please refer TMC429 datasheet for details).

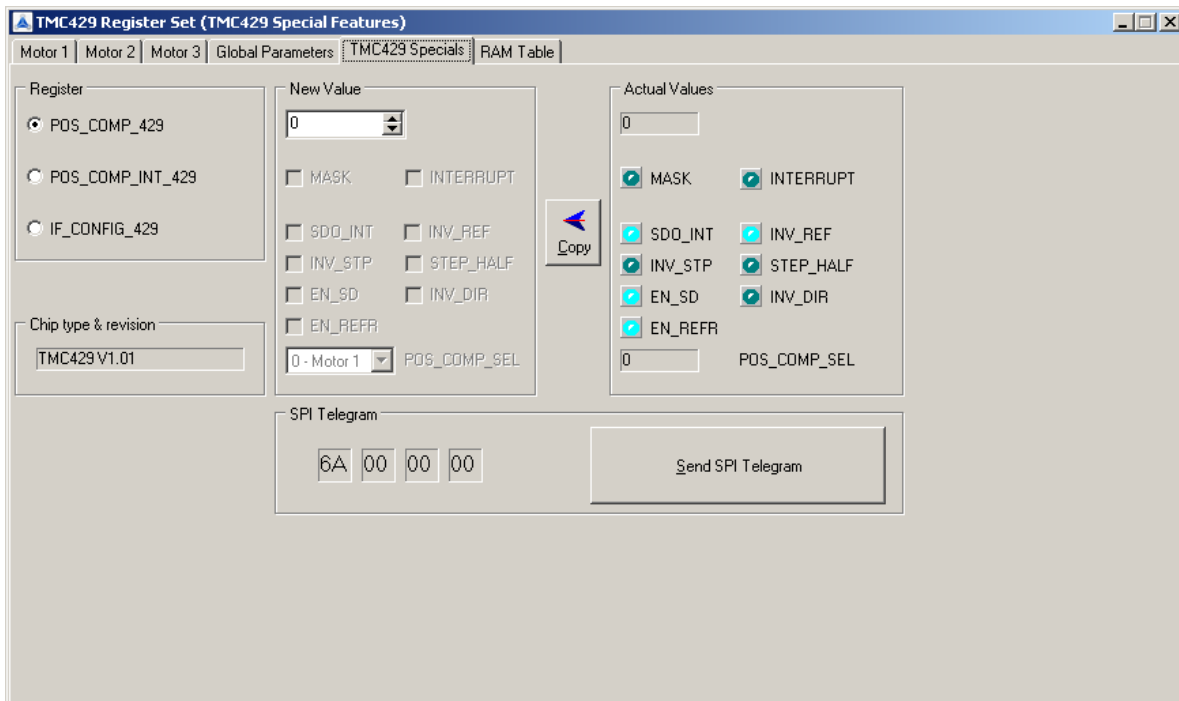

The **pos_comp_int_429** register holds an interrupt mask and interrupt flag bit (please refer TMC429 datasheet for details).

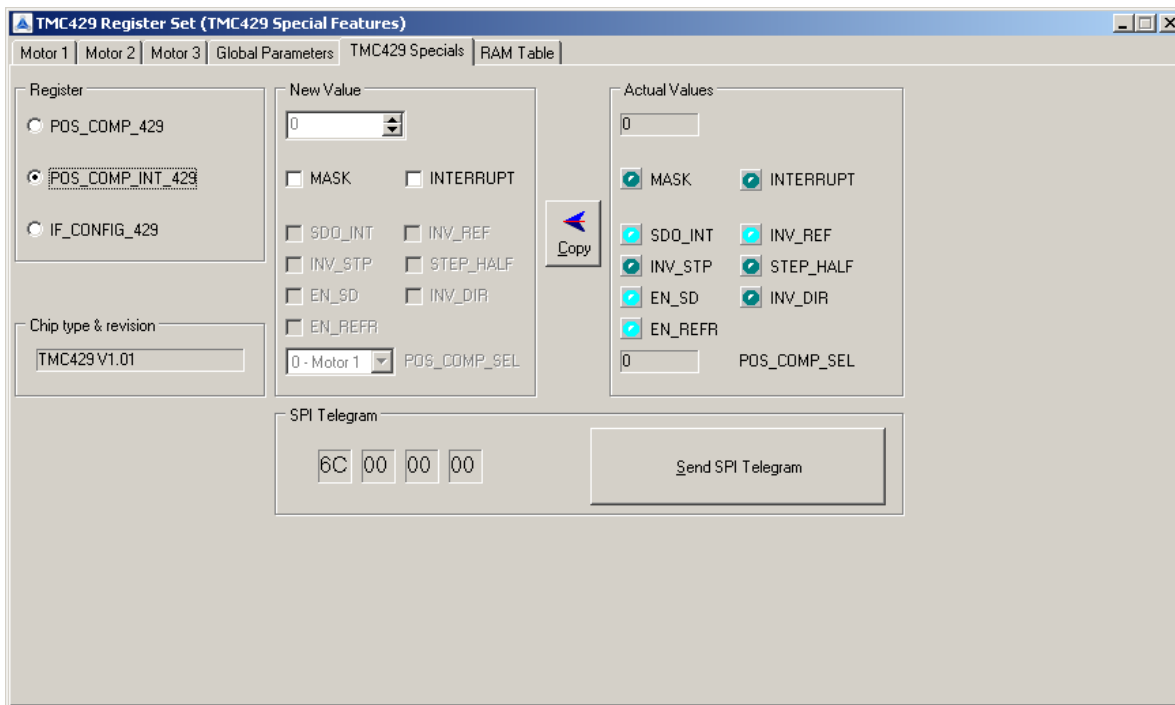

The **pos_comp_sel** selects one of three motors for compare of the position register of the associated motor (please refer TMC429 datasheet for details).

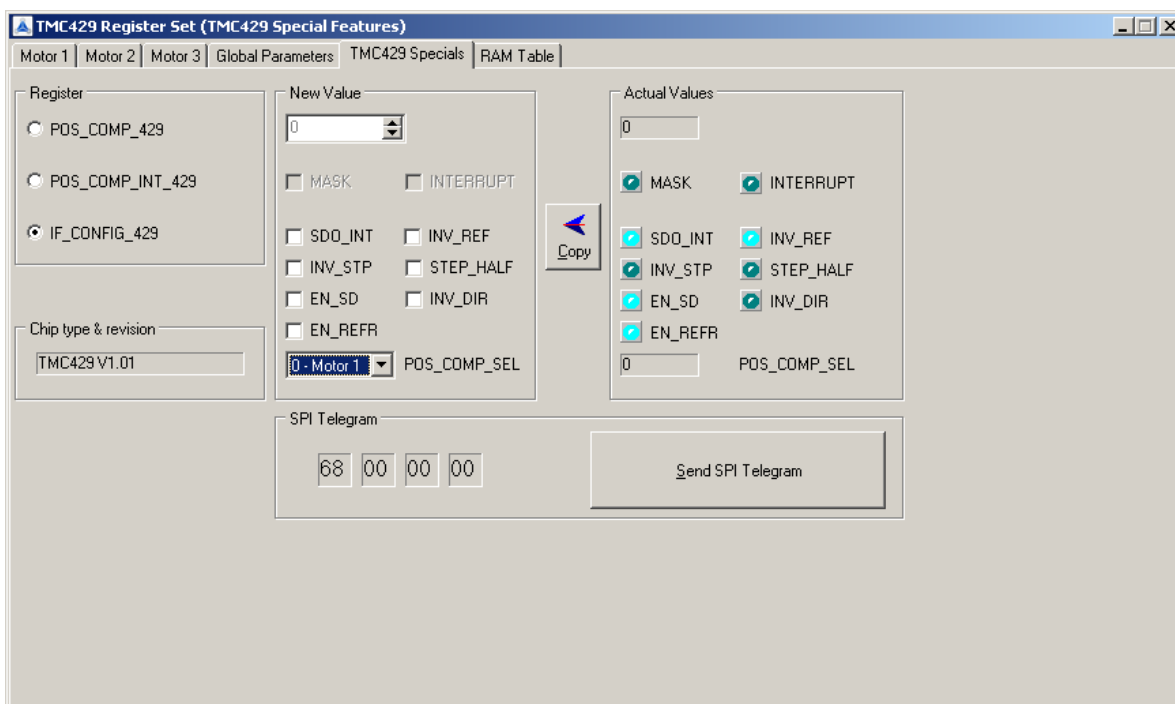

The RAM Table tab is for read and write of the TMC429 configuration RAM. It is initialized by the firmware of the evaluation board after power on reset.

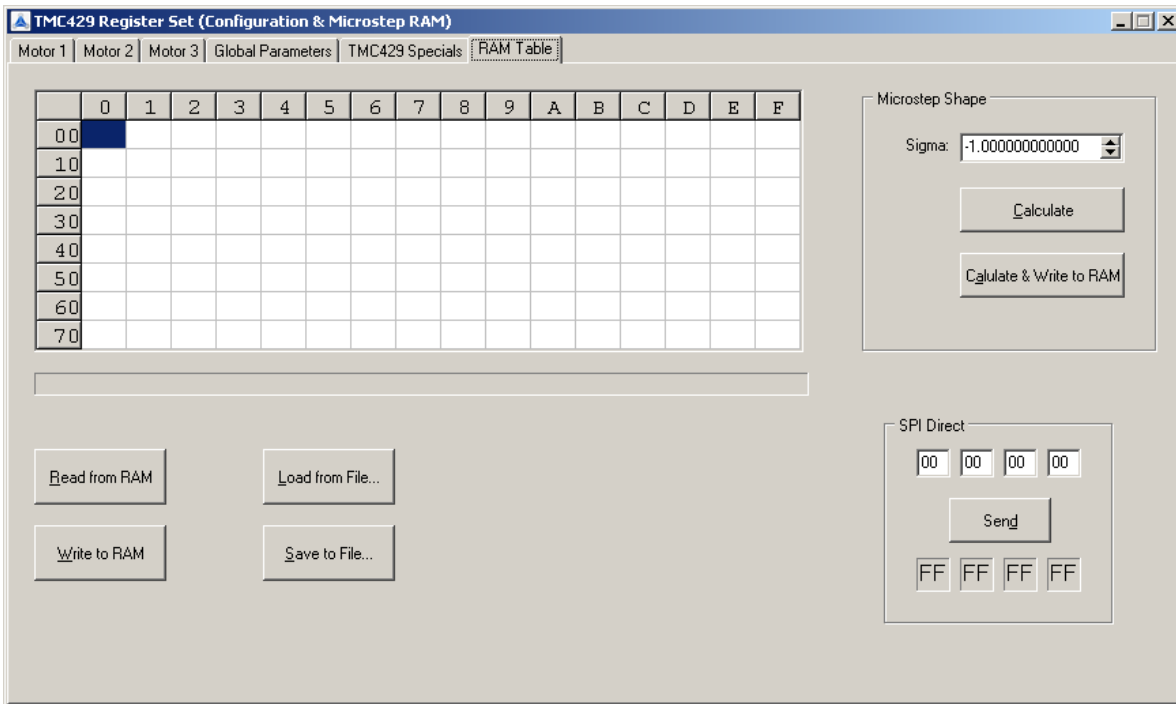

One can read from RAM (button Read from RAM) and write the RAM (button Write to RAM) manually. To change something within the RAM one first needs to read the RAM. In Addition to read and write, one can load RAM content from a file (button Load from RAM) or write an actual RAM content to a file (button Save to File...). The RAM holds the SPI configuration of the stepper motor driver chain and a quarter sine wave table. This is need for when driving stepper motor drivers via SPI.

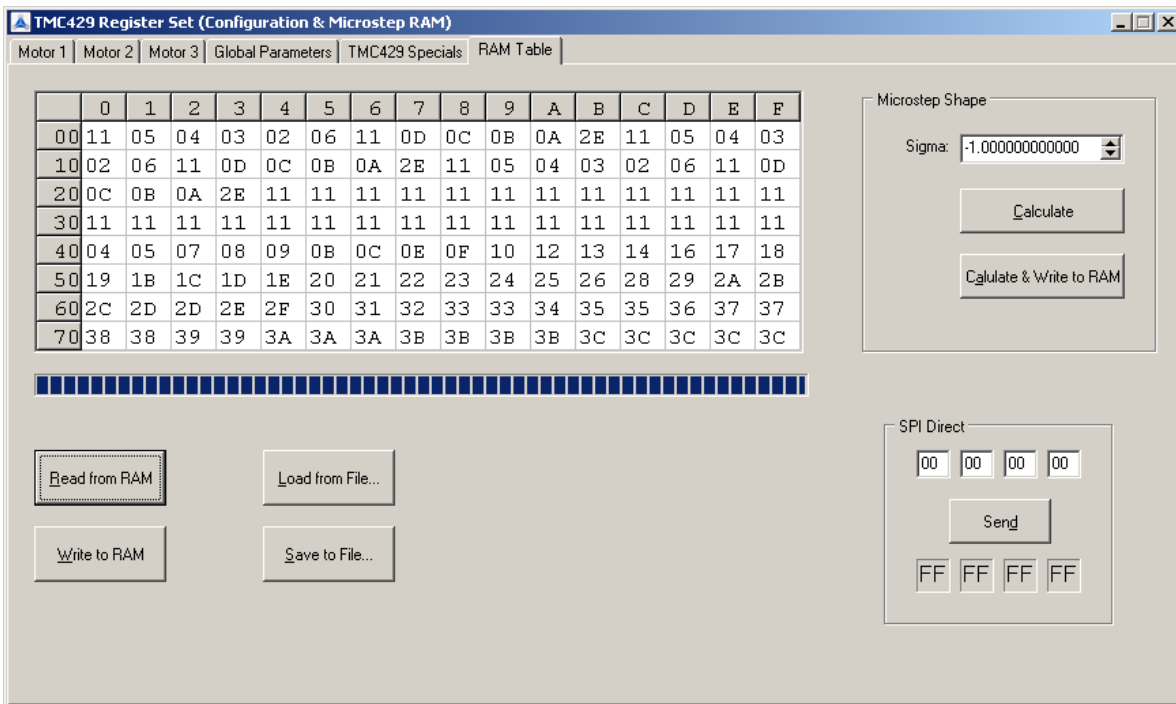

The button TMC26x coolStep... opens the configuration window for the TMC26x drivers. The three drives can be selected individually with the dropdown box. Motor 1 is driven by the TMC262, motor 2 by the TMC261 and motor 3 by the TMC260. The configuration options are the same for all three driver chips and are grouped in tabs by the SPI registers of the drivers. For detailed description of all options, please refer to the TMC260/TMC261/TMC262 datasheet.

The first tab contains the settings of the DRVCTRL register.

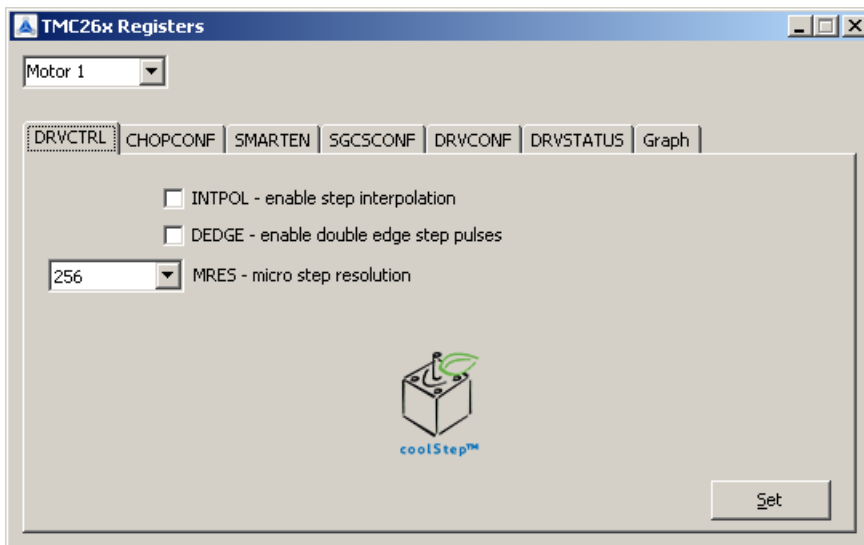

The second tab CHOPCONF allows setting the parameters for the chopper of the driver.

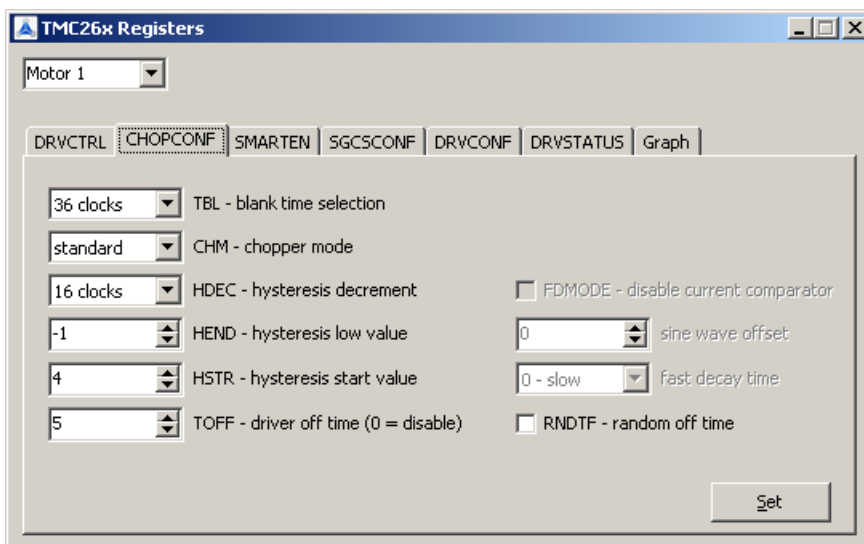

The SMARTEN tab contains the settings for the coolStep feature of the driver.

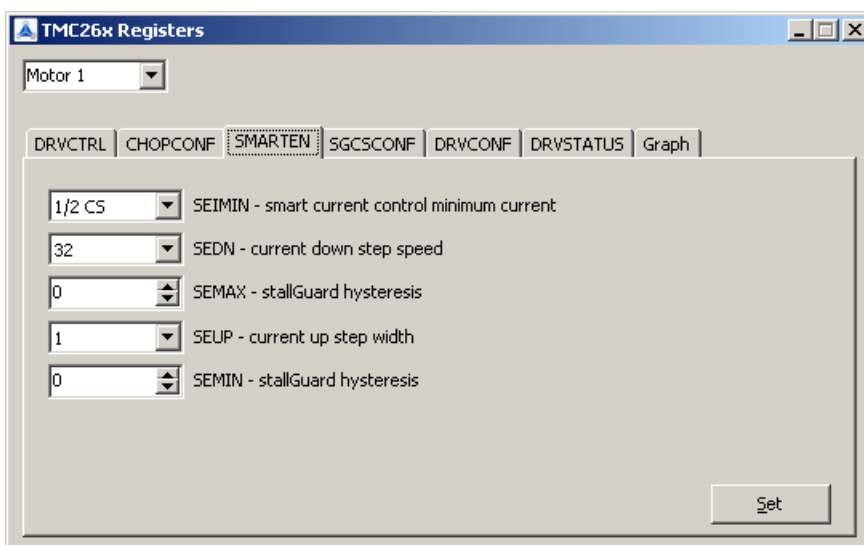

The tab SGCSCONF gives access to the adjustment of the stallGuard™ value and the setting of the current scale value which controls the maximum driver current.

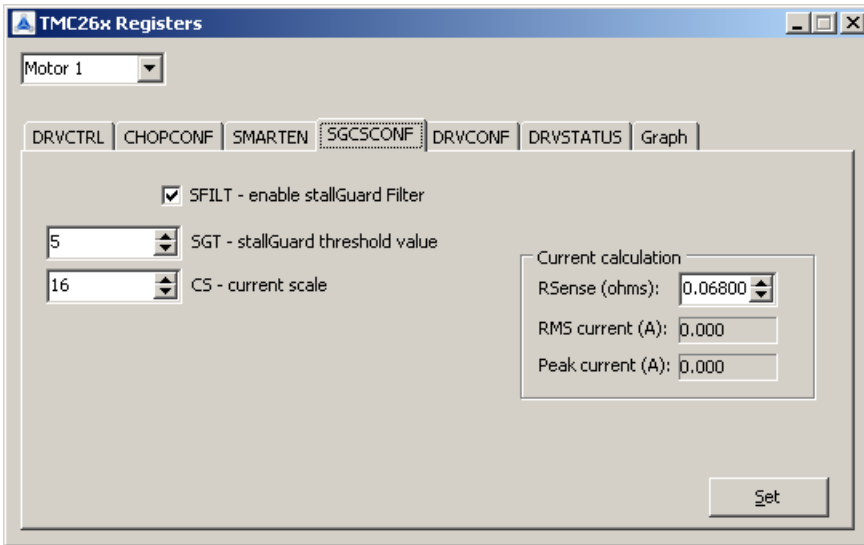

Hint: RSsense: Motor 1 ⇔ 0.068Ω, Motor 2 ⇔ 0.150Ω, Motor 3 ⇔ 0.150Ω.

In the DRVCONF tab, the parameters of the gate drivers can be modified.

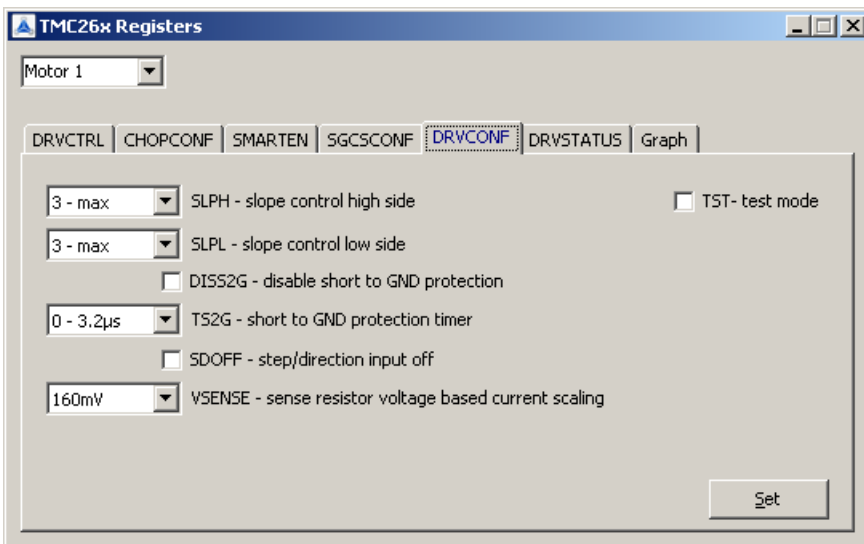

The DRVSTATUS tab provides an overview of the status values returned by the driver.

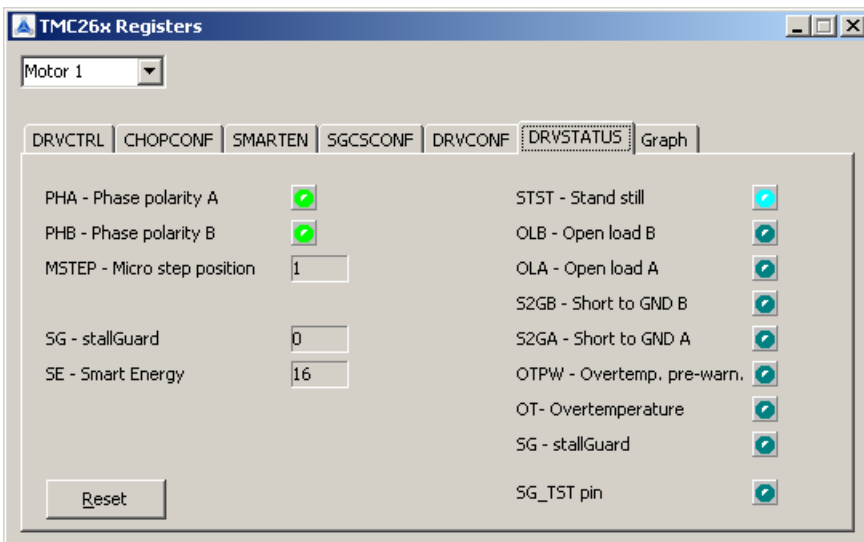

The Graph tab provides a graphical representation of the used current setting, which is equal to the CS setting on the SGCSCONF tab if the smart energy function is not used and the measured stallGuard value.

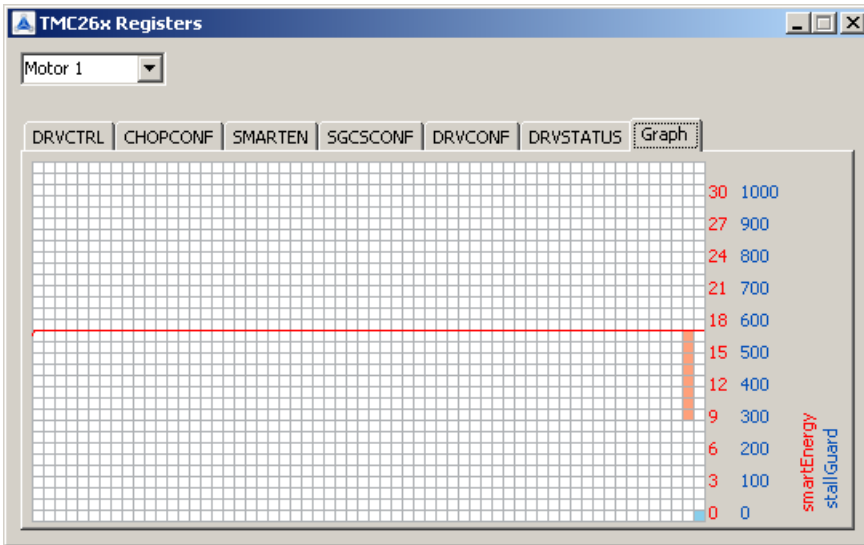

The button TMC429 Graphics... shows the following window that gives a graphical representation of the motion data on a single tab for each of the three motors.

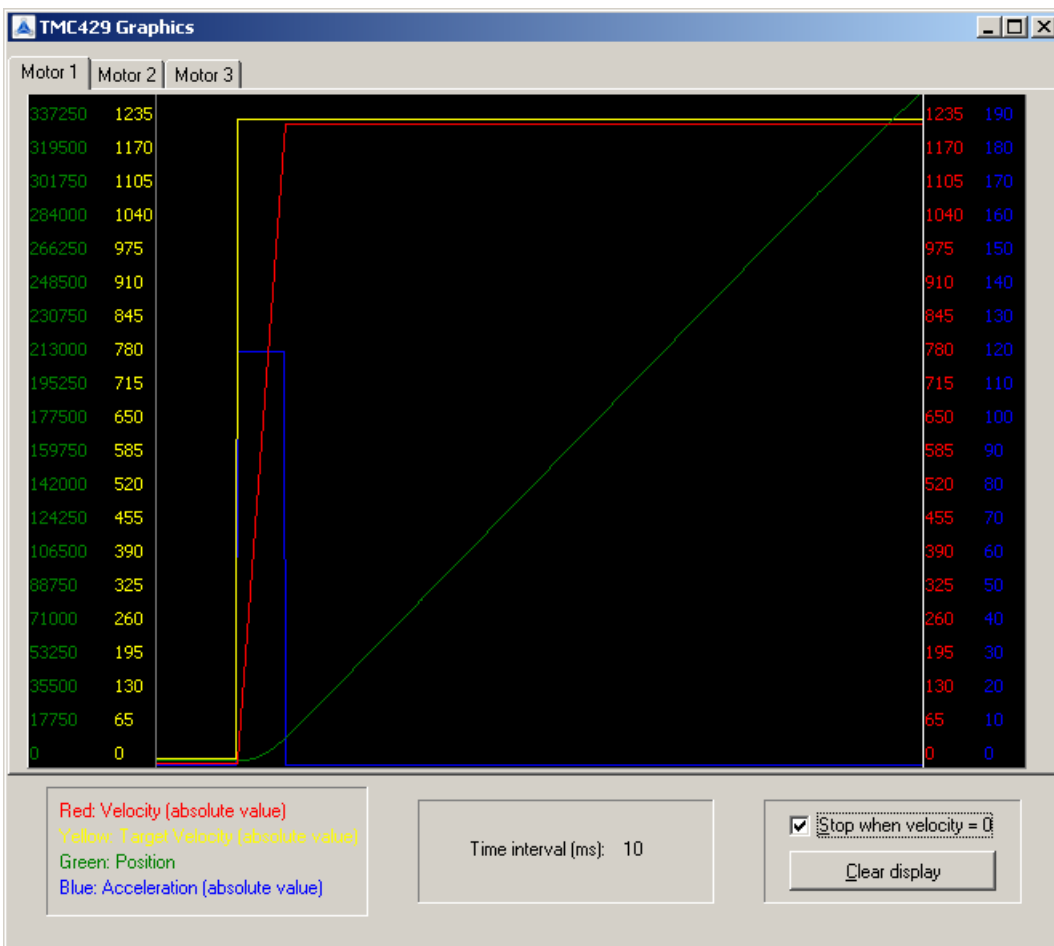

The button TMC424 Encoder... opens this window with access to the TMC424 configuration and position registers. For each of the three encoder inputs, the resolution along with parameters and the position as well as the common interrupt settings can be modified. The actual position values of the three encoders are read permanently. For a detailed explanation of the registers, please refer to the TMC424 datasheet.

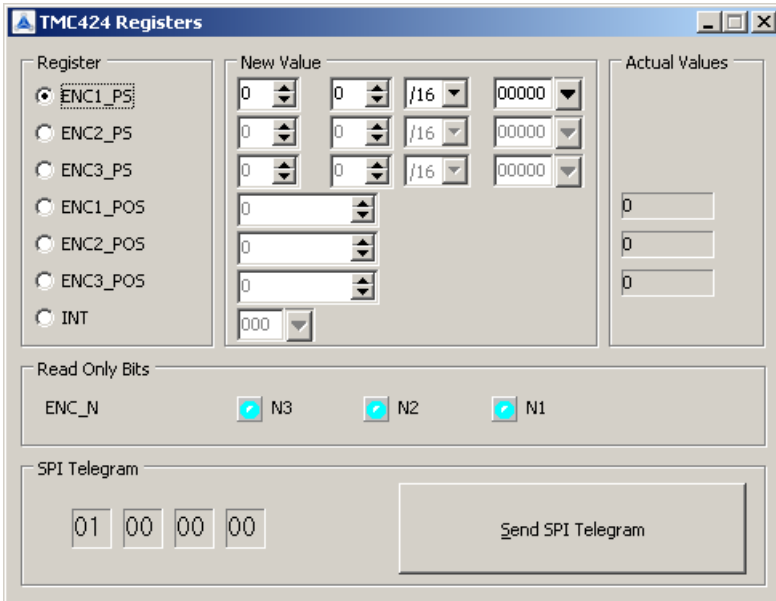

The button Board Settings... shows the following window, that allows to enable or disable each of the three drivers by direct control of the ENN lines. It also gives the possibility to change between Step/Direction and SPI mode for Motor 1 (driven by the TMC262) and change the clock frequencies generated by the microcontroller for the TMC429 motion controller and the TMC26x drivers.

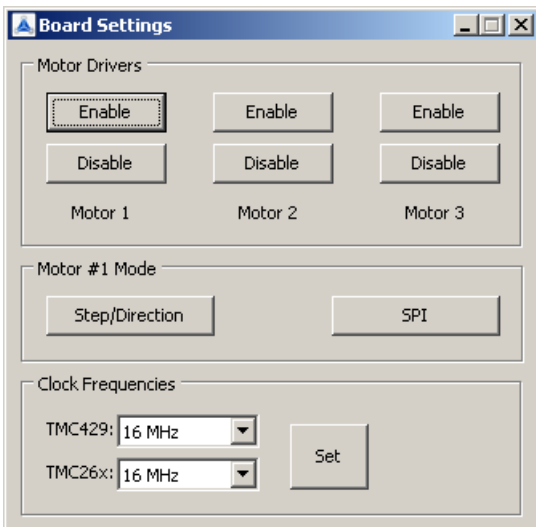

8 TMCL

TMCL, the TRINAMIC Motion Control Language, is described in separate documentations, which refer to the specific products (e.g. Firmware Manual). The manuals are provided on www.trinamic.com. Please refer to these sources for updated data sheets and application notes. The TMCL is for evaluation close to user application.

8.1 Communicating with PC

The communication with the PC takes place via TMCL commands.

8.1.1 Binary Command Format

Every command has a mnemonic and a binary representation. When commands are sent from a host to a module, the binary format has to be used. Every command consists of a one-byte command field, a one-byte type field, a one-byte motor/bank field and a four-byte value field. So the binary representation of a command always has seven bytes. When a command is to be sent via RS232 or USB interface, it has to be enclosed by an address byte at the beginning and a checksum byte at the end. In this case it consists of nine bytes.

The binary command format for RS232/USB is as follows:

Bytes	Meaning
1	Module address
1	Command number
1	Type number
1	Motor or Bank number
4	Value (MSB first!)
1	Checksum

- The checksum is calculated by adding up all the other bytes using an 8-bit addition.

Checksum calculation

As mentioned above, the checksum is calculated by adding up all bytes (including the module address byte) using 8-bit addition. Here are two examples to show how to do this:

- in C:

```
unsigned char i, Checksum;
unsigned char Command[9];

//Set the "Command" array to the desired command
Checksum = Command[0];
for(i=1; i<8; i++)
    Checksum+=Command[i];

Command[8]=Checksum; //insert checksum as last byte of the command
//Now, send it to the module
```
- in Delphi:

```
var
    i, Checksum: byte;
    Command: array[0..8] of byte;

//Set the "Command" array to the desired command

//Calculate the Checksum:
Checksum:=Command[0];
for i:=1 to 7 do Checksum:=Checksum+Command[i];
Command[8]:=Checksum;
//Now, send the "Command" array (9 bytes) to the module
```

8.1.2 Reply Format

Every time a command has been sent to a module, the module sends a reply.

The reply format for RS232/USB is as follows:

Bytes	Meaning
1	Reply address
1	Module address
1	Status (e.g. 100 means "no error")
1	Command number
4	Value (MSB first!)
1	Checksum

- The checksum is also calculated by adding up all the other bytes using an 8-bit addition.
- When using CAN bus, the first byte (reply address) and the last byte (checksum) are left out.
- Do not send the next command before you have received the reply!

8.1.3 Direct Register Access

Direct access to registers of the TMC429 takes place via TMCL user functions. This allows the user to write own software that communicates directly with the IC.

9 Life Support Policy

TRINAMIC Motion Control GmbH & Co. KG does not authorize or warrant any of its products for use in life support systems, without the specific written consent of TRINAMIC Motion Control GmbH & Co. KG.

Life support systems are equipment intended to support or sustain life, and whose failure to perform, when properly used in accordance with instructions provided, can be reasonably expected to result in personal injury or death.

© TRINAMIC Motion Control GmbH & Co. KG 2013

Information given in this data sheet is believed to be accurate and reliable. However neither responsibility is assumed for the consequences of its use nor for any infringement of patents or other rights of third parties, which may result from its use.

Specifications are subject to change without notice.

All trademarks used are property of their respective owners.



10 Revision History

10.1 Document Revision

Version	Date	Author	Description
0.01	2011-FEB-24	LL	Initial version
	2011-MAR-03	LL	first draft version
0.02	2011-MAR-04	LL	USB connector corrected (USB-B), no additional TMCL™ EEPROM
	2011-MAR-04	LL	screen shots of the evaluation software added
	2011-MAR-14	LL	power supply connector corrected; order code removed from documentation (pls. refer www.trinamic.com for order codes);
	2011-MAR-15	LL	section "communicating with PC" adapted from PD-140 manual
1.00	2011-MAY-02	LL, SL	first version published
1.01	2011-MAY-11	LL	updated concerning naming changes to TMC429-TMC26x-EVAL
1.02	2011-MAY-16	SK	Updated pictures of board and layout for board version 1.1
2.00	2011-JUL-14	LL	Updated concerning SPI Extender (ExtSPI) for board 2.0; new RESET jumper J207 for the ARM micro controller to disable it for external control via ExtSPI
2.01	2013-NOV-04	SD	<ul style="list-style-type: none"> - Front page new - SPI extender/connector description corrected - Changes related to the design
2.02	2015-JUN-22	BD	Info for external SPI usage.

Table 10.1 Document revision

10.2 Hardware Revision

Version	Date	Description
TMC429-EVAL V1.0	2010-NOV-05	TMC429 Evaluation board prototype board w/o TMC424
TMC429-EVAL V1.1	2011-FEB-24	TMC429 Evaluation board, with TMC260/261/260 and TMC424
TMC429+TMC26x-EVAL V1.1	2011-MAY-16	Evaluation board with TMC429, TMC260/261/260 and TMC424
TMC429+TMC26x-EVAL V2.0	2011-AUG-02	Evaluation board with TMC429, TMC260/261/260 and TMC424 as v.1.1 but with SPI connector ExtSPI with additional pins that allow control via external processor via cable without the need of soldering; the ExtSPI connector (former 10 pin, J406) is replaced by a 20 pin connector (now labeled X801) with additional signals that the user can control the TMC429, TMC26x, TMC424 with its own controller; new RESET jumper for the ARM micro controller to disable it for external control via ExtSPI; clock inputs of TMC429, TMC424, TMC26x available at ExtSPI connector; TMC424 is now connected to SPI 0 of the ARM (and the flash memory is now connected to the separate SPI channel SPI 1) to make the firmware example more transparent; for the former version the SPI channel 1 was used for both TMC424 and flash memory; MTR now labeled "Monitor" with  as additional symbol; picture of evaluation board updated;

Table 10.2 Hardware revision

10.3 Firmware Revision

Version	Date	Description
2.00	2010-NOV-05	TMC429 Evaluation board prototype board w/o TMC424
2.02	2011-MAR-17	TMC429 Evaluation board, with TMC260/261/260 and TMC424, does not yet support ADIO
2.03	2011-AUG-02	TMC429 Evaluation board, with TMC260/261/260 and TMC424, does not yet support ADIO
2.04	2012-NOV-30	Disable via link of Debug UART RXD-TXT

Table 10.3 Firmware revision

10.4 Software Revision (PC Application Software Revision)

Version	Date	Description
1.00	2010-NOV-05	TMC429 Evaluation board prototype board w/o TMC424
1.02	2011-MAR-17	TMC429 Evaluation board, with TMC260/261/260 and TMC424, does not yet support ADIO
1.03	2011-MAI-02	interim version with naming TMC429-EVAL
1.04	2011-MAI-11	naming changed to TMC429-TMC26x-EVAL

Table 10.4: Software revision

11 References

[TMC260/TMC261/TMC260]	TMC262 / TMC261 / TMC260 Datasheet
[TMC429]	TMC429 Datasheet
[TMC424]	TMC424 Datasheet
[TMCL-IDE]	TMCL-IDE User Guide

Please refer to www.trinamic.com