

LOC		DIST		REVISIONS			
A	66	P	LYR	DESCRIPTION	DATE	OWN	APVD
		-		SEE SHEET 1			

FEED TYPE MECHANICAL

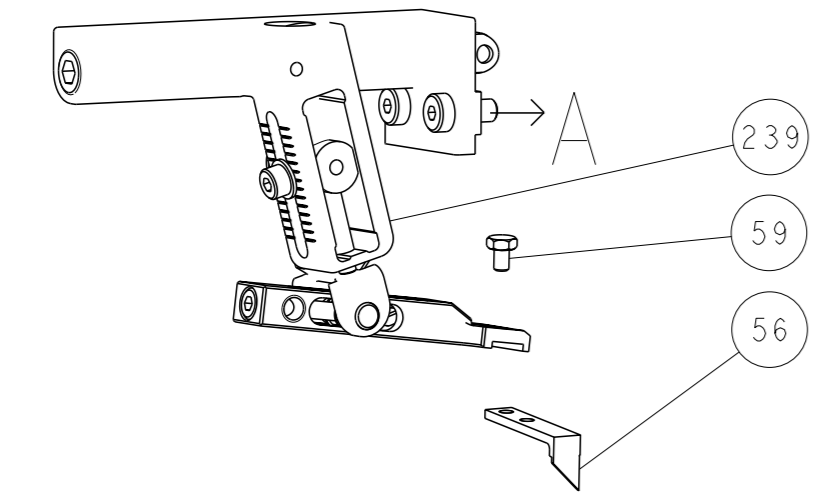

PNEUMATIC

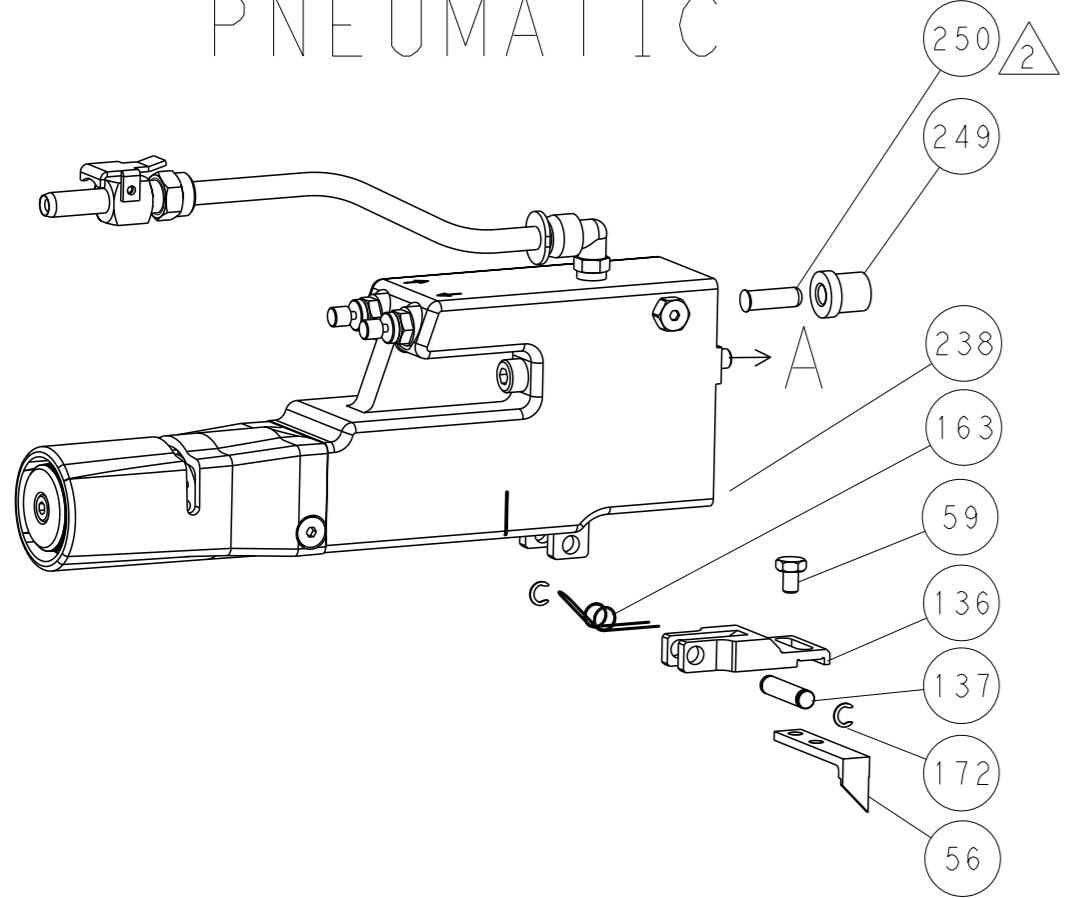

SERVO LATCH PLATE

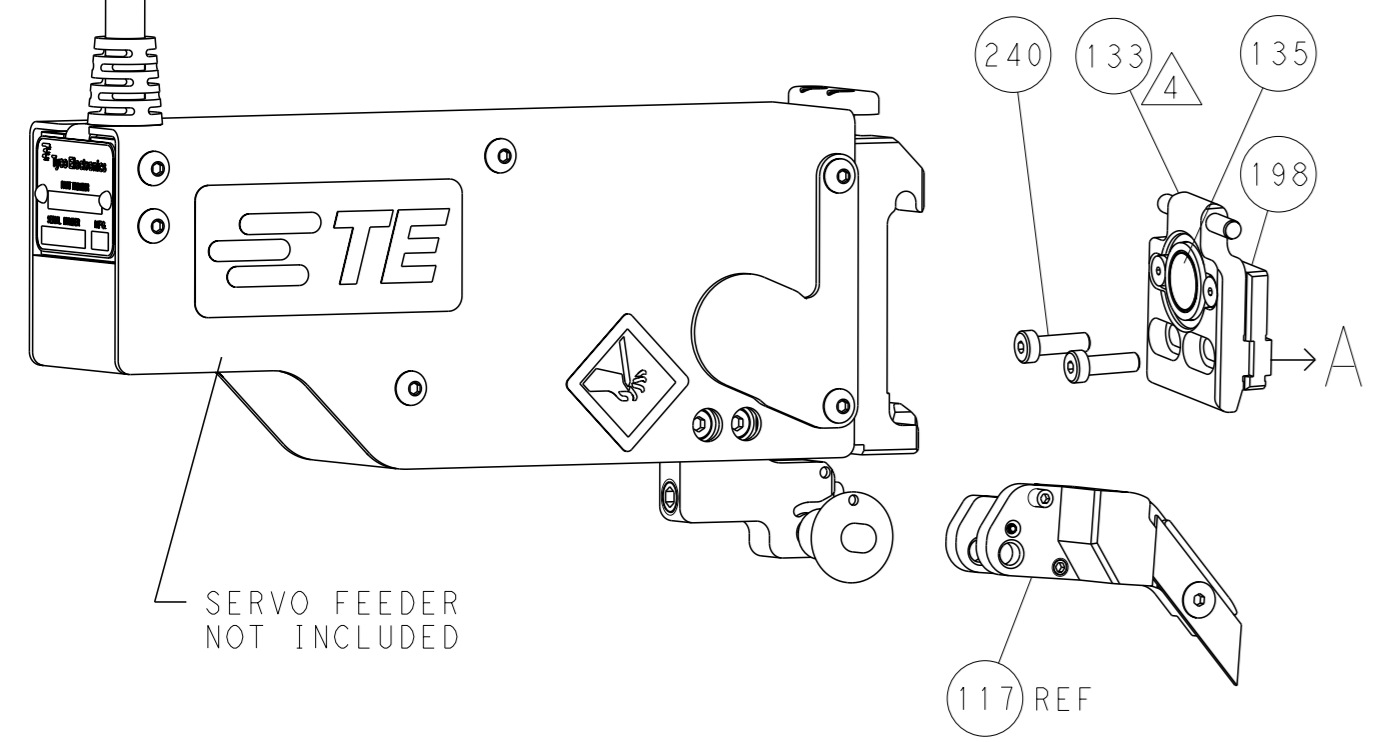

CAM POSITIONS

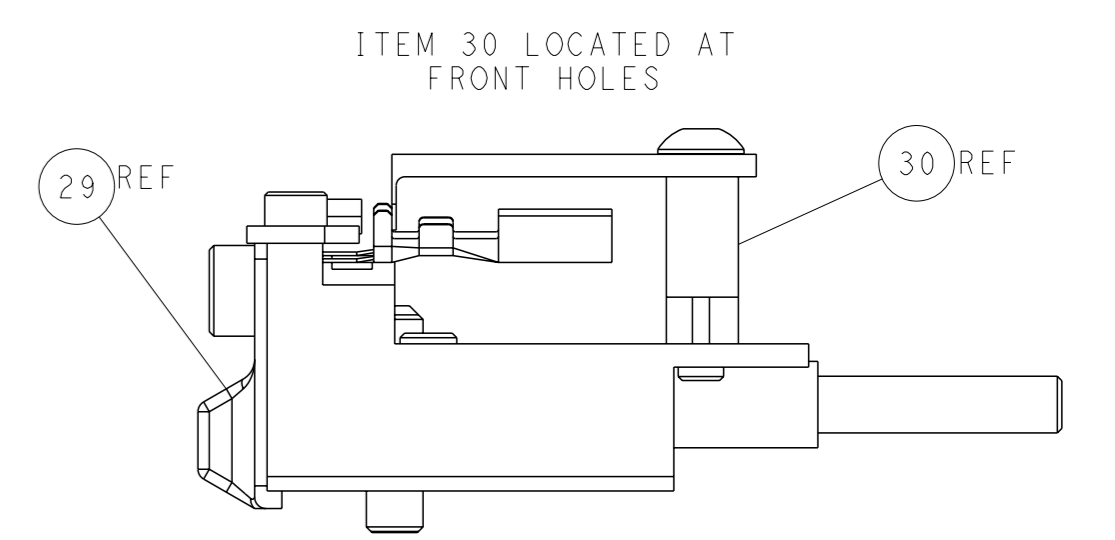
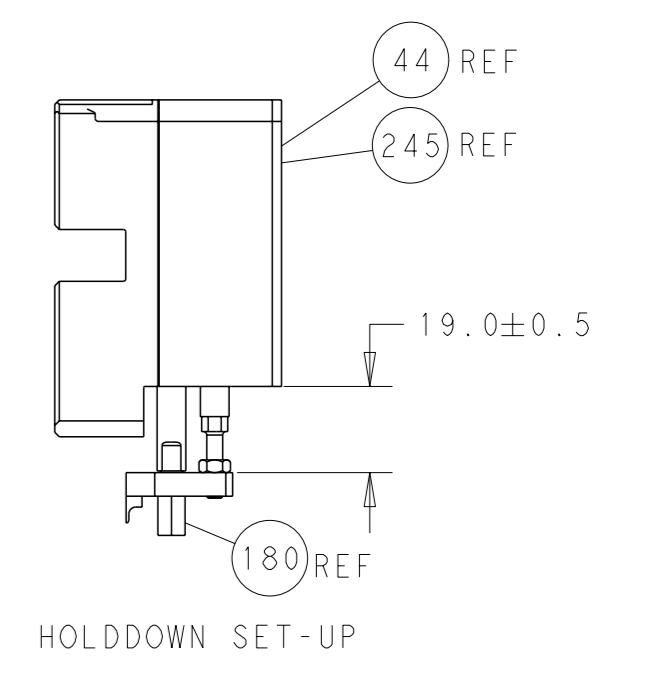
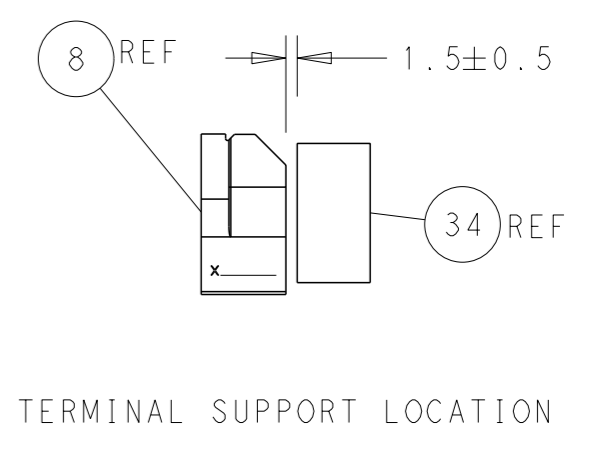
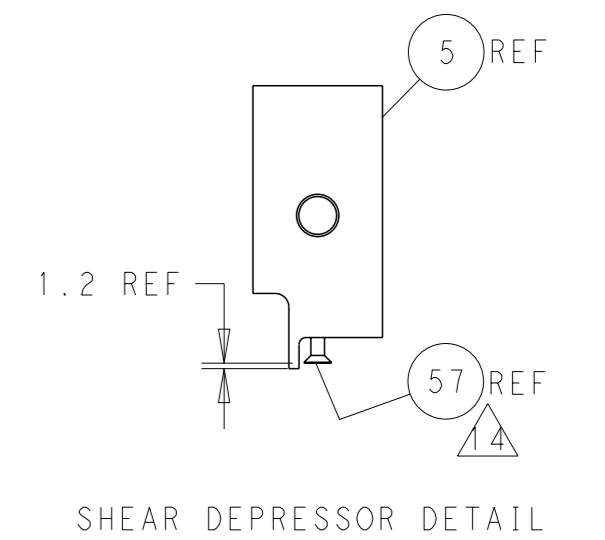
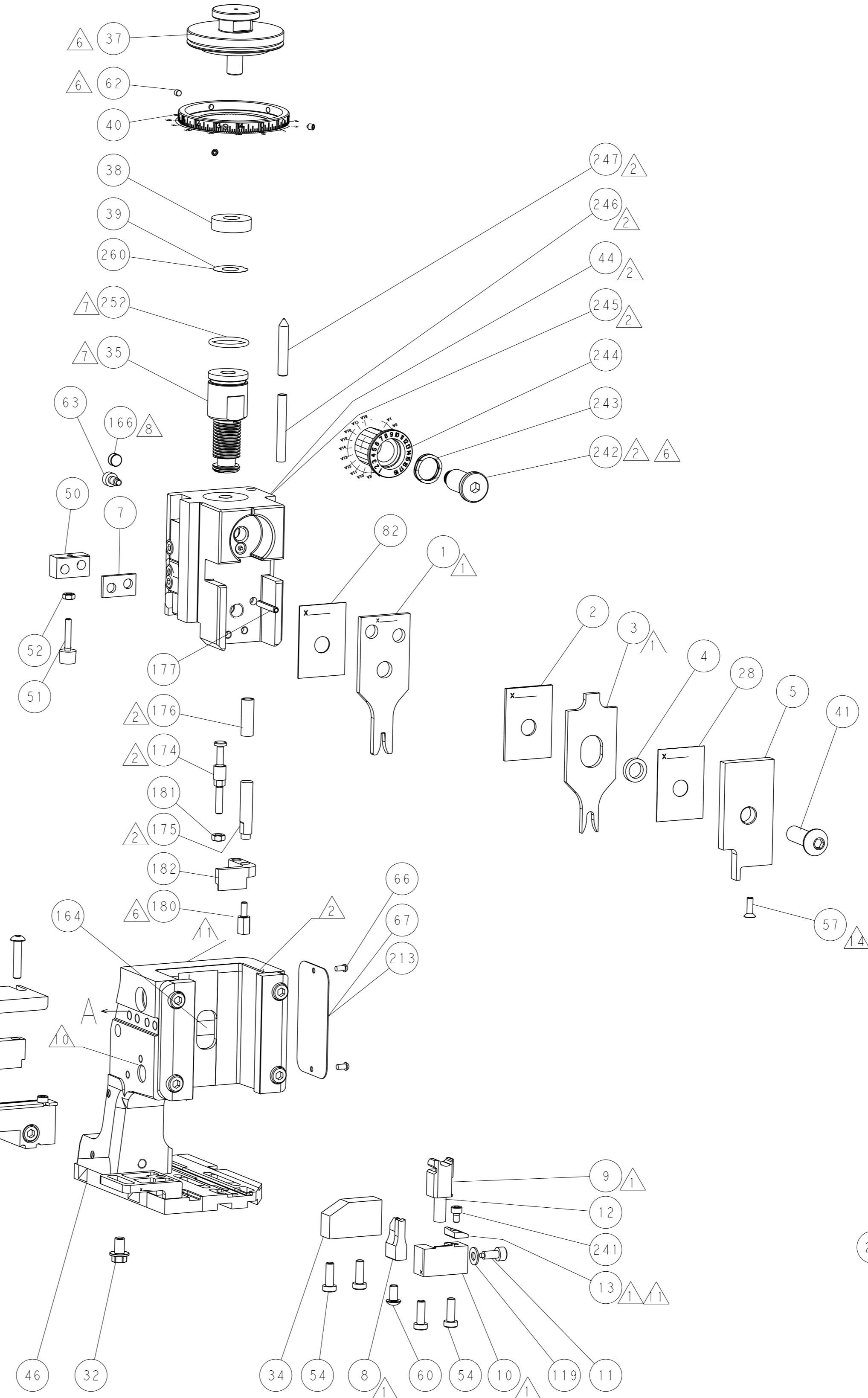
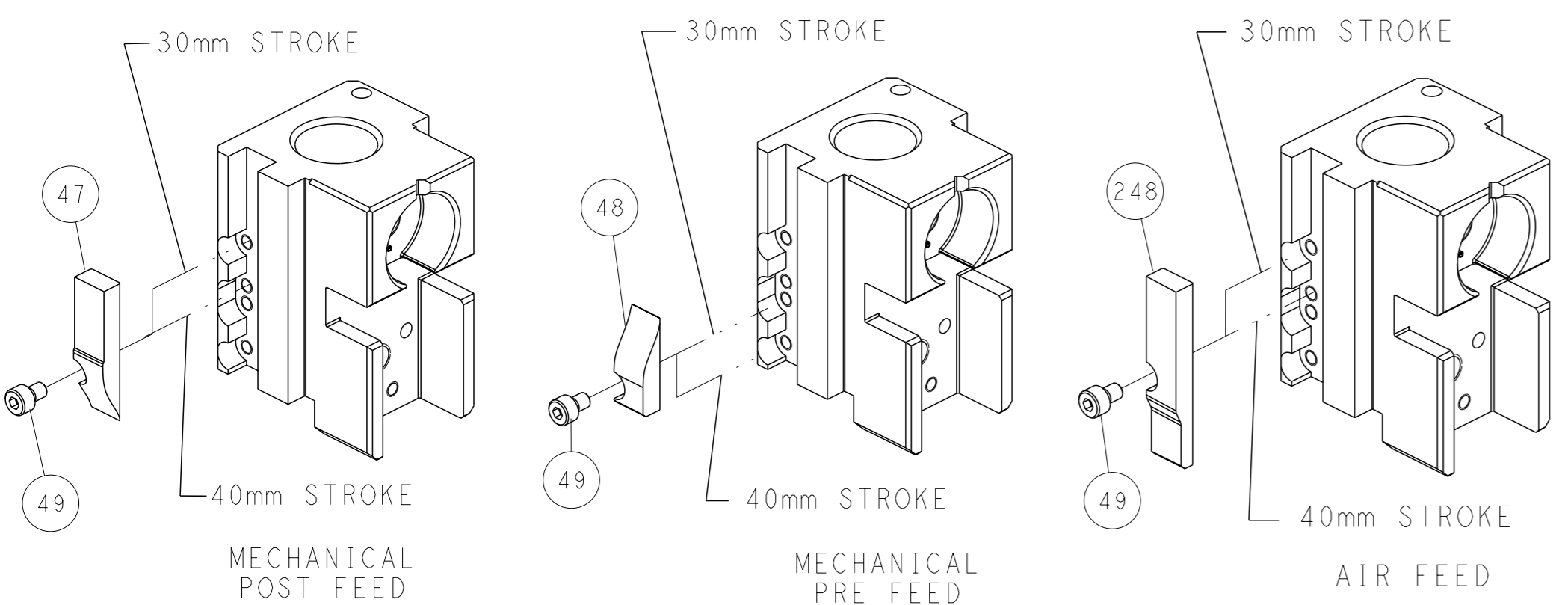

ATLANTIC VERSION
 Shown on sheets 1 of 4 & 2 of 4
 (Pacific version shown on sheets 3 of 4 & 4 of 4)

DIMENSIONS: mm 		TOLERANCES UNLESS OTHERWISE SPECIFIED: 0 PLC ± 1 PLC ± 2 PLC ± 3 PLC ± 4 PLC ± ANGLES ±		OWN: H. HUANG 09OCT2013 CHK: L. ZHANG 09OCT2013 APVD: J. GUO 09OCT2013 PRODUCT SPEC APPLICATION SPEC WEIGHT: - MATERIAL: -		NAME: Ocean Side Feed Applicator SIZE: A1 CAGE CODE: 00779 DRAWING NO: C=2266070 SCALE: 1:2 SHEET: 2 of 4 REV: B1		TE Connectivity Harrisburg, PA 17105-3608 RESTRICTED TO: -	
--------------------	--	---	--	--	--	---	--	--	--

LOC	DIST	REVISIONS			
A	66	REV	DATE	OWN	APVD
-	SEE SHEET 1	-	-	-	-

FEED TYPE MECHANICAL

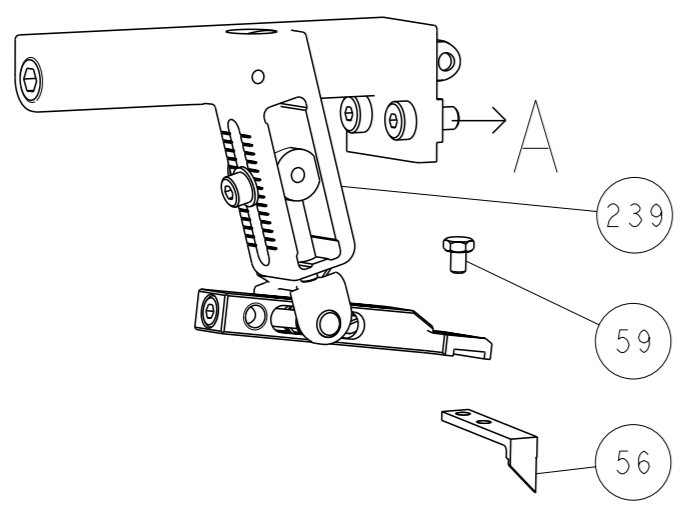

PNEUMATIC

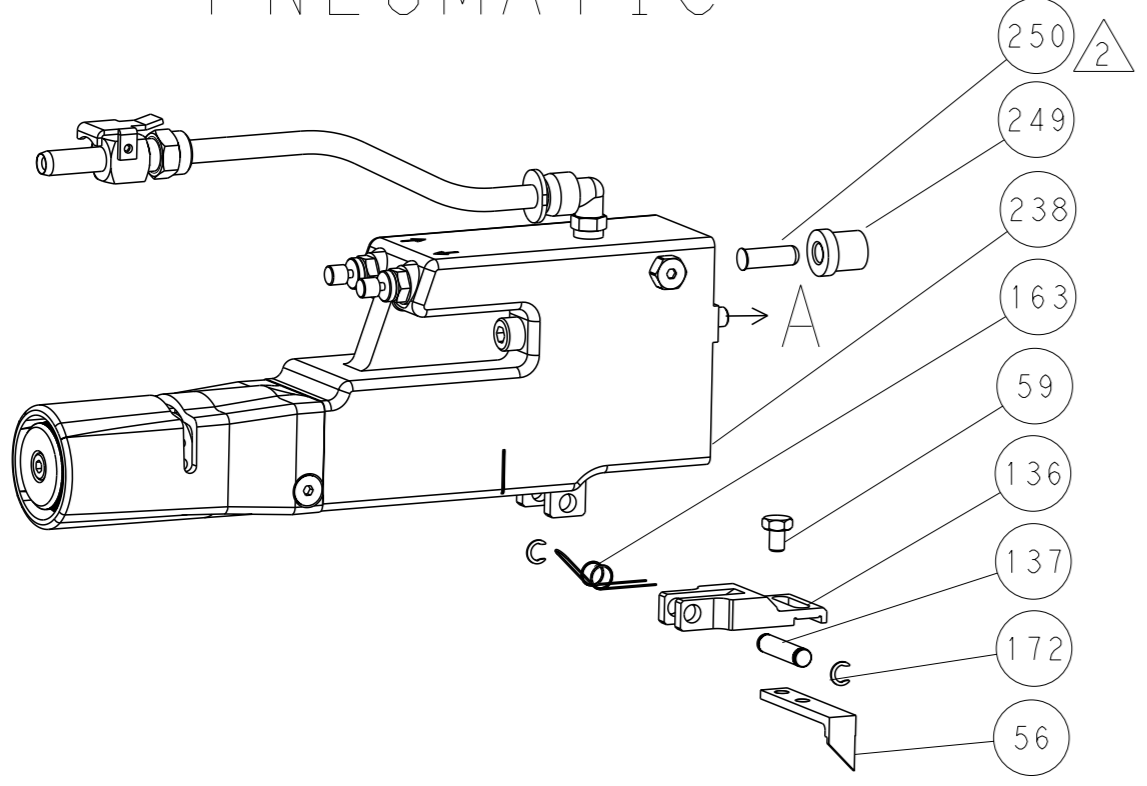

SERVO LATCH PLATE

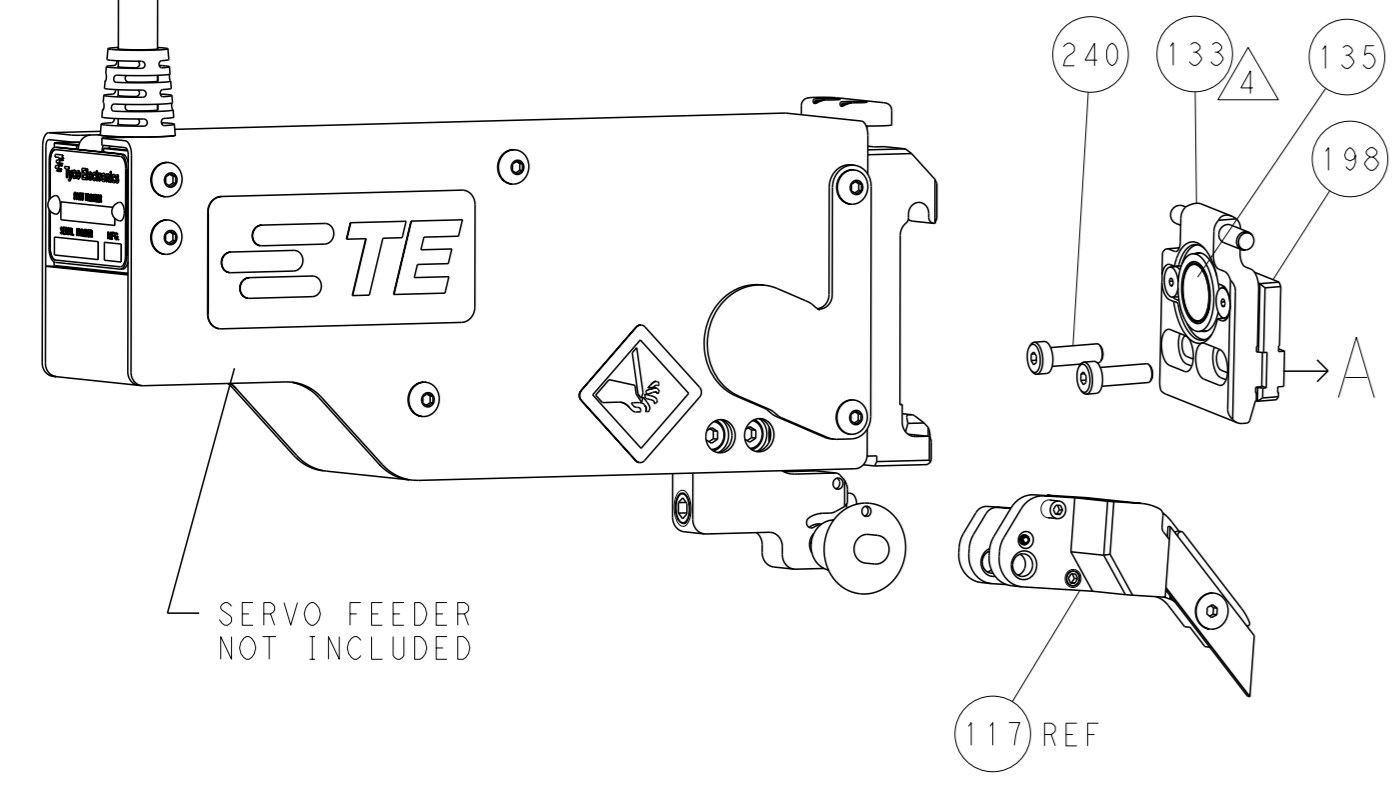

CAM POSITIONS

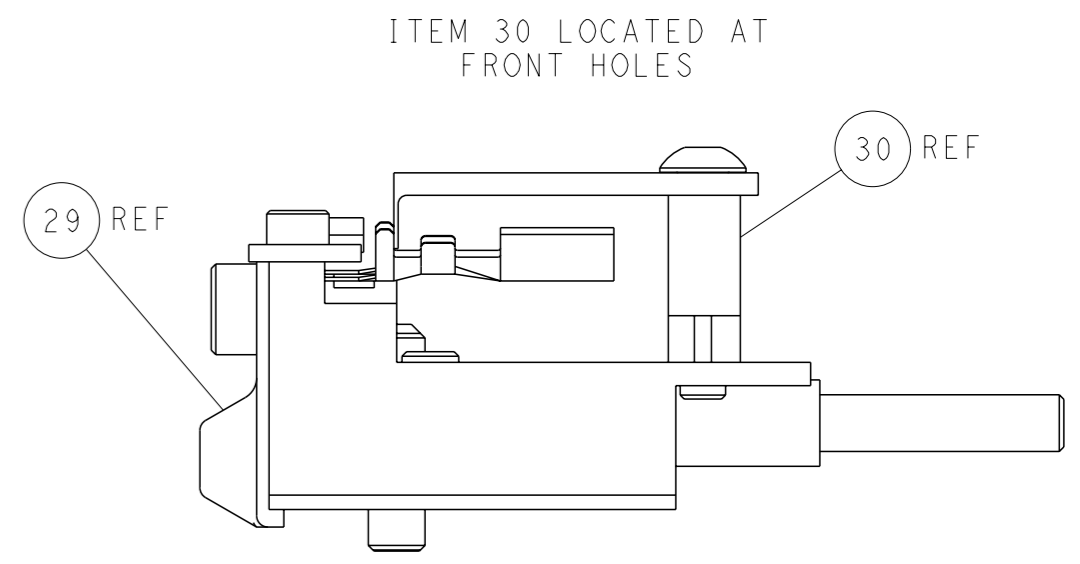
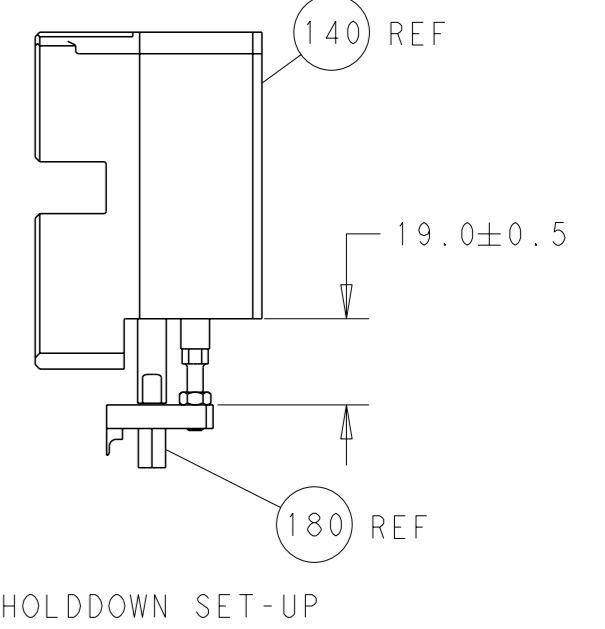
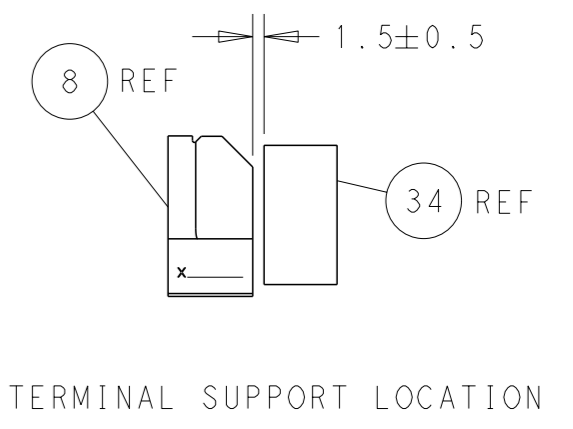
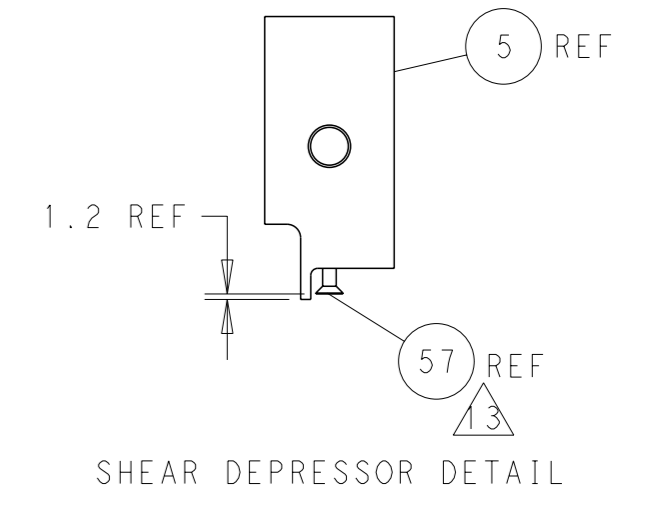
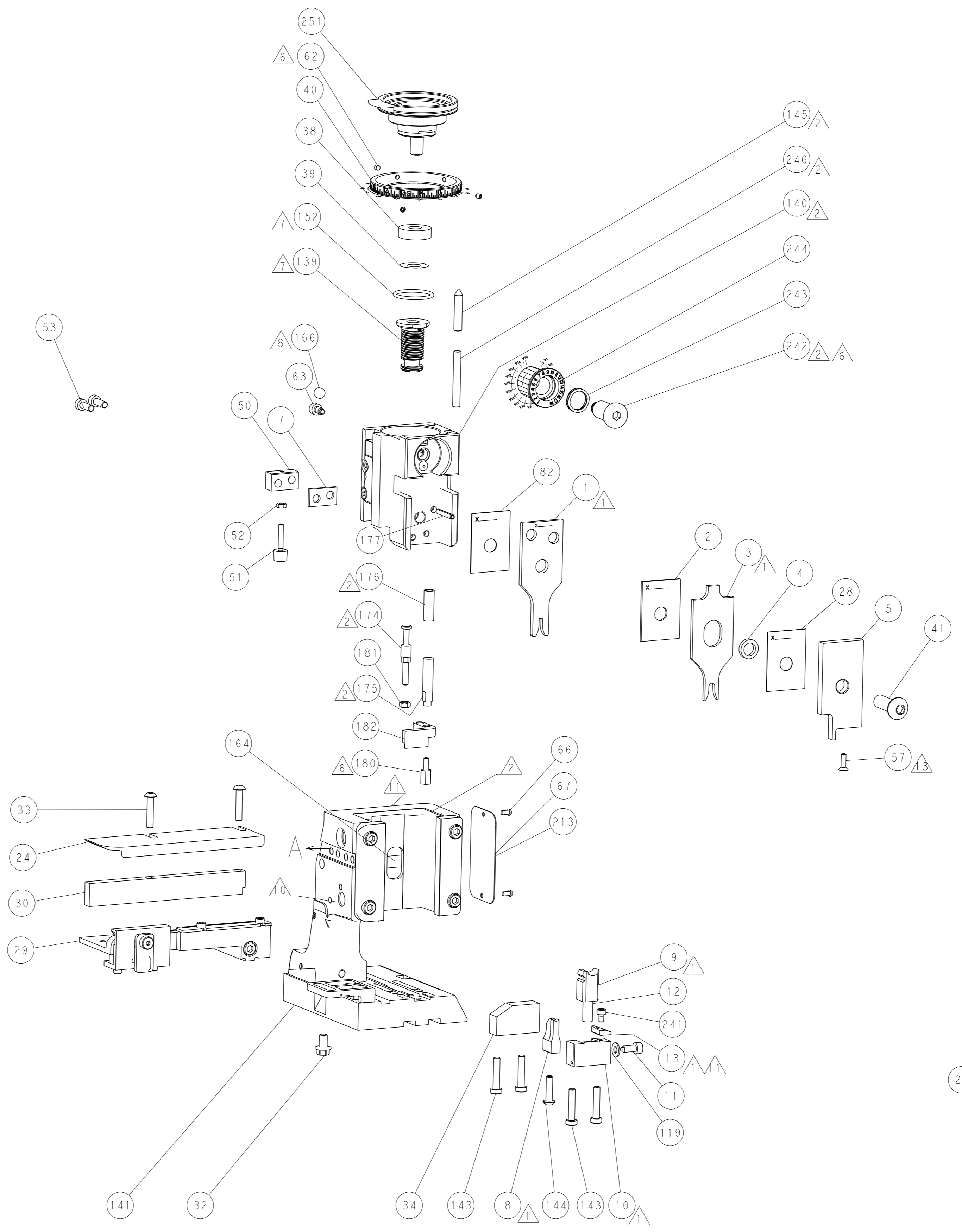
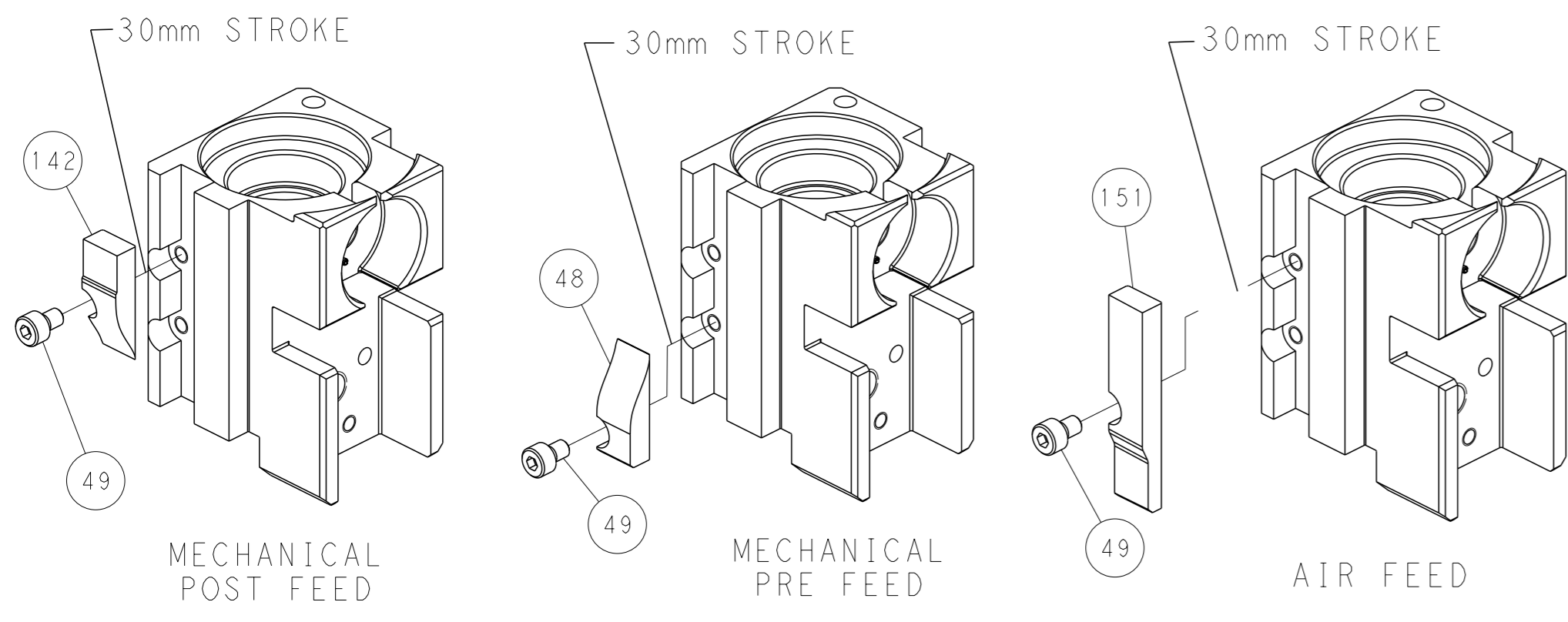

PACIFIC VERSION
 Shown on sheets 3 of 4 & 4 of 4
 (Atlantic version shown on sheets 1 of 4 & 2 of 4)

<small>THIS DRAWING IS A CONTROLLED DOCUMENT FOR TYCO ELECTRONICS CORPORATION. IT IS SUBJECT TO CHANGE AND THE CONTROL AND REVISIONS ORGANIZATION SHOULD BE CONTACTED FOR THE LATEST REVISION.</small>		OWN: H. HUANG 09OCT2013 CHK: L. ZHANG 09OCT2013 APVD: H. GUO 09OCT2013	NAME: Ocean Side Feed Applicator SIZE: A1 CAGE CODE: 00779 DRAWING NO: C=2266070	RESTRICTED TO: - SCALE: 1:2 SHEET: 4 of 4 REV: B1
DIMENSIONS: mm TOLERANCES UNLESS OTHERWISE SPECIFIED: 0 PLC ± 1 PLC ± 2 PLC ± 3 PLC ± 4 PLC ± ANGLES FINISH ±	WEIGHT: - MATERIAL: -	APPLICATION SPEC: - PRODUCT SPEC: -	CUSTOMER ACCESSIBLE PRODUCTION DRAWING	